



LJMU Research Online

Alkhafaji, D and Wylie, SR

Application of microwave analysis to monitoring slug flow in pipeline networks

<http://researchonline.ljmu.ac.uk/id/eprint/15737/>

Article

Citation (please note it is advisable to refer to the publisher's version if you intend to cite from this work)

Alkhafaji, D and Wylie, SR (2018) Application of microwave analysis to monitoring slug flow in pipeline networks. Instrumentation Mesure Metrologie, 17 (3). ISSN 1631-4670

LJMU has developed **LJMU Research Online** for users to access the research output of the University more effectively. Copyright © and Moral Rights for the papers on this site are retained by the individual authors and/or other copyright owners. Users may download and/or print one copy of any article(s) in LJMU Research Online to facilitate their private study or for non-commercial research. You may not engage in further distribution of the material or use it for any profit-making activities or any commercial gain.

The version presented here may differ from the published version or from the version of the record. Please see the repository URL above for details on accessing the published version and note that access may require a subscription.

For more information please contact researchonline@ljmu.ac.uk

<http://researchonline.ljmu.ac.uk/>

Application of microwave analysis to monitoring slug flow in pipeline networks

Dhirgham Alkhafaji^{1,*}, S. R. Wylie²

1. Babylon University, College of Engineering, Iraq

2. Liverpool John Moores, Faculty of Engineering & Technology, UK

d.alkhafagi@yahoo.com

ABSTRACT. One of the industrial problems with pipe line system management is recognizing and measuring multiphase in the slug flow. The present study investigates a resonant cavity made of aluminum in a vertical flow direction. S-parameter measurements have been taken for dynamic mixtures in a microwave frequency range from 1-6 GHz. The volume fractions of water-oil-gas in slug flow can be determined by two horizontal shifts in the resonant frequencies based on the reflection and transmission of electromagnetic waves. Results which have been carried out in resonance range between 3.5- 4.5 GHz. The shifts correspond to the water volume fraction in the mixture (water-air-oil) when in slug flow. The experimental results have confirmed that this non-intrusive and non-invasive sensor could provide an accurate phase fraction measurement for a multiphase mixture in slug flow.

RÉSUMÉ. L'un des problèmes industriels liés à la gestion des systèmes d'oléoducs consiste à reconnaître et à mesurer plusieurs phases dans le slug flow. La présente étude examine une cavité résonante en aluminium dans le sens vertical de l'écoulement. Des mesures de paramètres S ont été effectuées pour des mixtures dynamiques dans une plage de fréquences micro-onde allant de 1 à 6 GHz. Les fractions volumiques d'eau, de pétrole et de gaz dans le slug flow peuvent être déterminées par deux changements horizontaux des fréquences résonante basés sur la réflexion et la transmission d'ondes électromagnétiques. Les résultats ont été réalisés dans une plage de résonance entre 3,5 et 4,5 GHz. Les changements correspondent à la fraction de volume d'eau de la mixture (eau-air-pétrole) dans le slug flow. Les résultats expérimentaux ont confirmé que ce capteur non intrusif et non invasif pourrait fournir une mesure précise de la fraction de phase pour une mixture multiphase dans le slug flow.

KEYWORDS: microwave sensor, slug flow, non-invasive, resonant cavity.

MOTS-CLÉS: Capteur du micro-onde, Slug flow, Non invasif, Cavité résonnante.

DOI:10.3166/ I2M.17.479-489 © 2018 Lavoisier

1. Introduction

Monitoring slug flow in multiphase flow is a significant problem in industrial, oil industrial and waste water pipelines. The advantages of non-invasive devices has led to the use of electromagnetic (EM) wave devices in phase monitoring. This development of EM sensors has attracted wide attention in recent years. This monitoring faces complex flow patterns of multiphase water, oil and gas mixtures. Using non-invasive sensors, like the microwave sensor discussed in this paper, is one solution to recognize the phenomenon of slug flow. In a two-phase flow regime, slug flow is when the pipe cross section is filled alternatively with gas and liquid. Slug flow belongs to a class of intermittent flow that has very distinctive features and it occurs under certain conditions in a two-phase gas-liquid flow. Slug flow is an unsteady phenomenon that is a combination of stratified flow and single phase flow (gas or vapor) as the liquid-bubble mass is pushed by gaseous mass. One of the industrial problems facing pipe lines systems is recognizing and measuring of slug flow. Flow measurement can be classified into three types: Phase velocity measurement, Phase density measurement and Phase fraction measurement (Thorn *et al.*, 1997). This study concentrates on the second type of measurement with real time and on-line measurement.

The literature survey shows many researchers working on different methods and using different technics such as Wang *et al.* (2010), Strazza *et al.* (2011), Shah *et al.* (2013), Tan *et al.* (2013), Silva and Hampel (2013), Filippov *et al.* (2014), Abd (2014), An *et al.* (2014), Tan *et al.* (2014). These researchers used techniques including Gamma Ray Attenuation, Electrical Impedance, Coriolis Mass Flow and Nuclear Magnetic Resonance to measuring multiphase fraction. Recently the other researchers, Almuradi *et al.* (2015) and Al-Kizwini *et al.* (2013) have used EM techniques to analyze different mixtures and phase fractions at rest inside a microwave cavity.

In the present work, the EM cavity technique has been used for analysis and measurement of dynamic multiphase slug flow.

2. Theory

Electrical permittivity is the complex quantity used to describe the dielectric properties that affects the velocity and attenuation of wave energy within materials (Komarov *et al.*, 1999). The permittivity of a mixture depends on the permittivity of its constituents. The relative permittivity is written as,

$$\varepsilon_r^* = \varepsilon_r' - i\varepsilon_r'' \quad (1)$$

The real part represents the stored energy when the material exposed to an electric field, while the imaginary part describes how energy is dissipated. The relative permittivity is frequency dependent, and this relationship can be modelled using the Debye equation,

$$\varepsilon_r' = \frac{\varepsilon_s - \varepsilon_\infty}{1 + \omega^2 \tau^2} + \varepsilon_\infty \quad (2)$$

where ε_s and ε_∞ represent the static and infinite permittivities, while ω and τ represent the angular frequency ($2\pi f$) in radians per second and the relaxation time in seconds, respectively,

The relation between the permittivity of the mixture and the measured reflected S-parameter can be approximated as (Challa *et al.*, 2008),

$$S_{11} = \frac{(\frac{1}{R}-R)(e^{-\gamma d}-e^{-\gamma d})}{D} \quad (3)$$

where R is the ratio of characteristic impedance with and without the tested material, d is the diameter of the material sample under test, and γ is the propagation constant.

$$D = \left(R + \frac{1}{R} + 2\right) e^{\gamma d} - \left(R + \frac{1}{R} - 2\right) e^{-\gamma d} \quad (4)$$

$$R = \sqrt{\frac{1 - (\frac{f_c}{f})^2}{\varepsilon'_{mr} - i\varepsilon''_{mr} - (\frac{f_c}{f})^2}} \quad (5)$$

$$\gamma = i \frac{\omega}{c} \sqrt{\varepsilon'_{mr} - i\varepsilon''_{mr} - (\frac{f_c}{f})^2} \quad (6)$$

where f_c is the cut-off frequency and c is the speed of light in a vacuum ($299792458 \text{ ms}^{-1}$). The subscript mr refers to relative mixture. For high loss situation,

$$\varepsilon''_{mr} \gg \varepsilon'_{mr} \quad (7)$$

3. Experimental set-up

The experimental setup of the microwave sensor system is shown in Fig.1. The main component is an aluminum cylindrical cavity, shown in Fig.2. The cavity (EM sensor) had with an internal diameter of 89mm, and a height of 98mm. The cavity contains two excitation ports (P_1 and P_2) ($\varnothing = 31.4\text{mm}$) each containing a copper loop antennas. The loop diameter is 25mm and the wire diameter is 1.5 mm. They are positioned vertically inside the cavity. The upper aperture ($\varnothing = 15\text{mm}$) is the entrance of the dynamic testing sample tubes. The experimental setup is simplified in the block diagram in figure 3.

The test sample tubes are made of polypropylene, and were designed to simulate the slug flow. Samples of slug flow were prepared by inserting plastic bubbles in the tested tub, which represent the air bubbles of slug flow. The mixture inside the sample was circulated by a rotary pump that controlled the flow velocity. The EM sensor was connected to a HP 68720 ET vector network analyzer (VNA) with a frequency range of 500 MHz to 20 GHz. The analyzer was connected to P_1 and P_2 through precision cables and suitable connector adaptors. Prior to the S-parameter measurements being taken, a full two port calibration was carried out to eliminate systematic errors. The

calibration procedure worked on a frequency range from 1 to 6 GHz. A laptop computer collected the reflection (S_{11}) and transmission (S_{21}) data over the given frequency range. The multiphase slug flow sample was prepared with a constant 15% air ratio and different water-oil mixture ratios (15:70, 25:60, 35:50, 45:40, 55:30, 65:20) by volume.

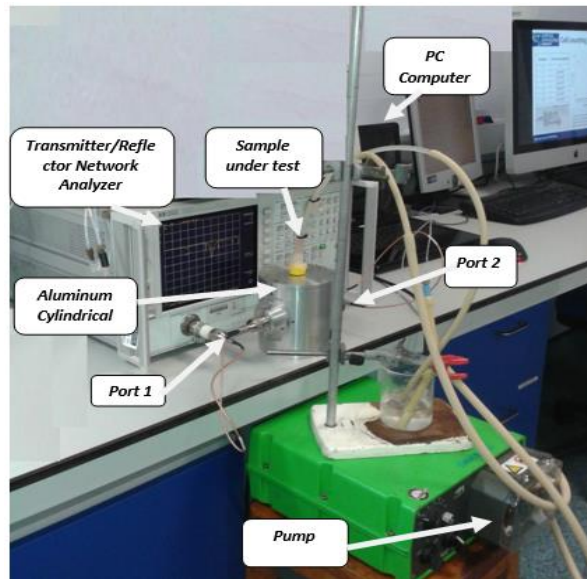

Figure 1. Experimental setup of EM sensor system using a cylindrical cavity



Figure 2. Aluminum cylindrical cavity

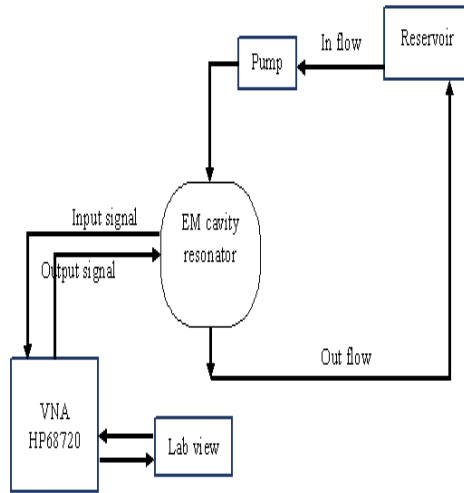

Figure 3. Block diagram of the experimental setup

4. Results & discussion

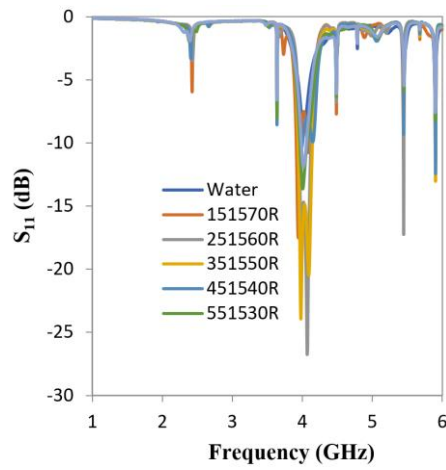

Figure 4. The S_{11} magnitude for slug flow between 1 and 6GHz

Figure 4 shows the S_{11} magnitude between 1 and 6 GHz for each multiphase flow. Different resonant peaks occur in the spectrum but the frequency shifts between 3.5

and 4.5 GHz, as shown in figure 5, were chosen for further analysis. Figure 6, shows the S_{11} magnitude as a function the fraction of the water in the slug flow mixture. The function can be approximated as linear. However, as shown in figure 7, there is no recognized shift differences in the resonance frequency due to change the water fractions in the components in the range between 3.5 and 4.5 GHz.

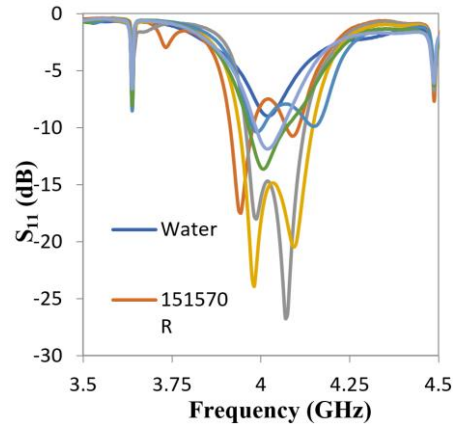

Figure 5. The S_{11} magnitude for slug flow between 3.5 and 4.5GHz

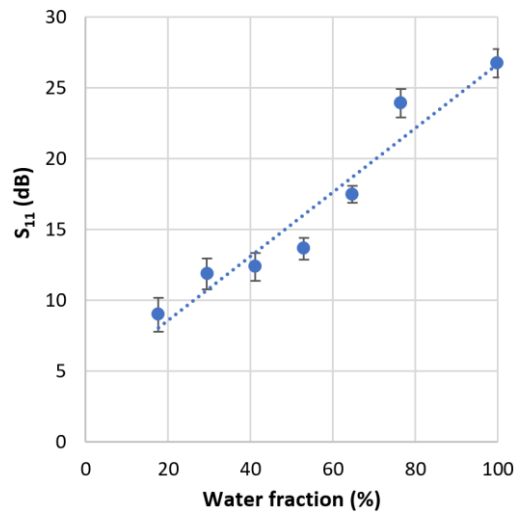

Figure 6. S_{11} magnitude as a function of water fraction in a water, oil and air mixture for slug flow with a 15% fixed air ratio

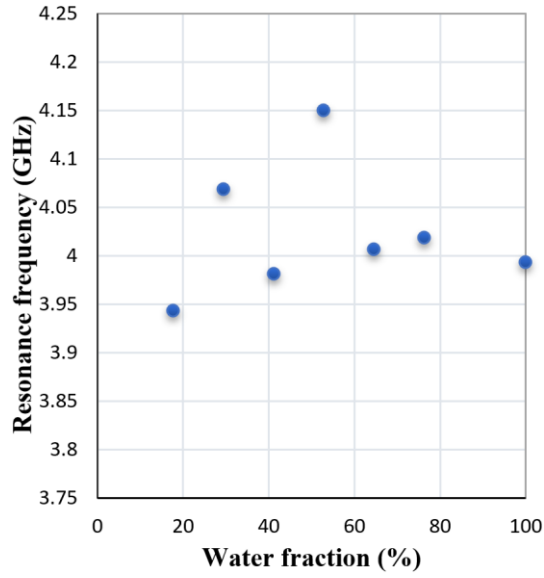

Figure 7. S_{11} peak frequency as a function of water fraction in a water, oil and air mixture for slug flow with a 15% fixed air ratio

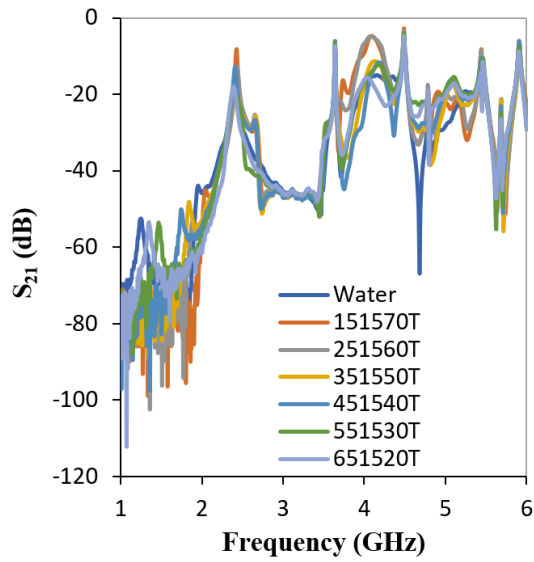

Figure 8. The S_{21} magnitude for slug flow between 1 and 6GHz

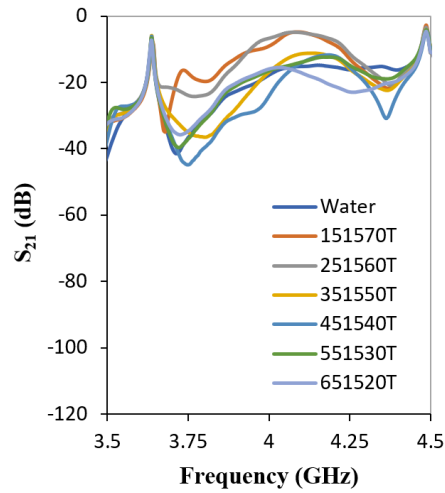

Figure 9. The S_{11} magnitude for slug flow between 3.5 and 4.5GHz

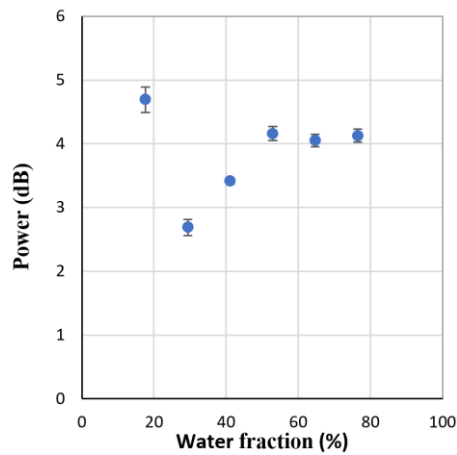

Figure 10. Transmitted power variation of S -parameter as a function of water fraction ratio in water, oil and air mixture for slug flow of 15% fixed air ratio based on the transmitted wave

The S_{21} magnitudes was also recorded for the range of frequencies between 1 and 6 GHz as shown in figure 8, and 3.5 to 4.5 GHz, as shown in figure 9. The resonant frequencies are not as easily identified in these figures and the power values is flat in

a way that the associated power cannot give clear indication about phase component fractions. For this, the power of the transmitted wave and the resonance frequency are shown in figures 10 and 11, respectively. It can be shown that no conclusion can be drawn as the components change in the fraction.

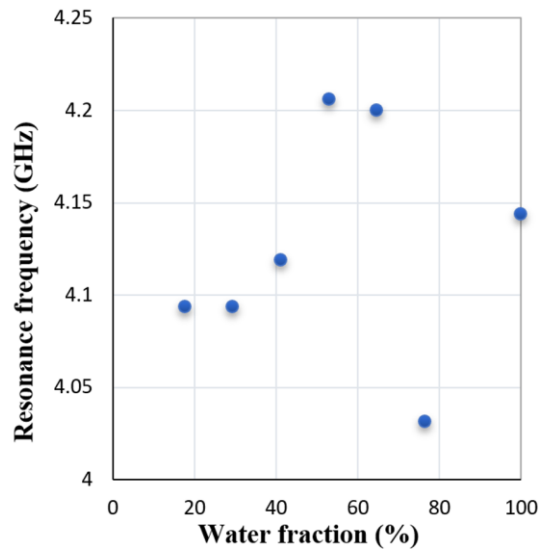

Figure 11. S_{21} peak frequency as a function of water fraction in a water, oil and air mixture for slug flow with a 15% fixed air ratio

5. Conclusions

The conclusions can be summarized as follows,

- For the multiphase slug flow, with the ratio of the air constant, the S_{11} magnitude can be used to determine the water fraction, and therefore the oil fraction.
- The S_{11} magnitude is an approximately linear function of the water fraction for the mixtures used.
- The transmitted wave of the sensor does not seem to be affected by the fraction of the components.
- The study introduced the S_{11} real time monitoring based on the reflected wave in the frequencies between 3.5 and 4.5 GHz as a standardized method to specify the water-oil-gas phase ratio in slug multiphase flow.

- (e) The measuring method used in this study is nondestructive and uses low power transmission (1.0 mW), which is applicable to a safe environment for the pipeline industry operators.

Acknowledgement

The author is grateful to Radio Frequency & Microwave Group at Faculty of Engineering and Technology, Liverpool John Moores University, Liverpool, UK, the Dean of the Faculty, Research Assistants and staff for their assistance and access to the laboratory facilities.

References

- Abd A. E. I. (2014). Inter comparison of gamma ray scattering and transmission techniques for gas volume fraction measurements in two phase pipe flow. *Nuclear Instruments Methods in Physics Research Section A: Accelerators, Spectrometers, Detectors and Associated Equipment*, Vol. 735, pp. 260-266.
- Al-Kizwini M. A., Wylie S. R., Al-Khafaji D. A., Al-Shamma'a A. I. (2013). The use of an EM mixing approach for the verification of an EM wave sensor for a two phase (oil–water) dispersed flow. *Flow Measurement and Instrumentation*, Vol. 32, pp. 35–40. <https://doi.org/10.1016/j.flowmeasinst.2013.03.004>
- Almuradi S. A. R., Abdul-Rasool A. A. A., Alkafaji D. A. H., Ateeq M., Al-shamma'a A. (2015). Temperature impact in electromagnetic non-invasive water/oil/gas multiphase real time monitoring. *Asian Journal of Engineering and Technology*, Vol. 3, No. 5, pp. 512-527.
- An Z., Ningde J., Lusheng Z., Zhongke G. (2014). Liquid hold-up measurement in horizontal oil-water two phase flow by using concave capacitance sensor. *Measurement*, Vol. 49, pp. 153-163. <https://doi.org/10.1016/j.measurement.2013.11.036>
- Challa R. K., Kajfez D., Gladden J. R., Elsherbeni A. Z. (2008). Permittivity measurement with non-standard waveguide by using TRL calibration and fractional linear data fitting. *Progress in Electromagnetics Research B*, Vol. 2, pp. 1-13.
- Filippov Y. P., Kakorin I. D., Panferov K. S. (2014). Influence of temperature on the algorithm to define salty water-in-oil flow characteristics. *International Journal of Multiphase Flow Journal*, Vol. 58, pp. 52-56. <https://doi.org/10.1016/j.ijmultiphaseflow.2013.08.008>
- Komarov V., Wang S., Tang J. (1999). Permittivity and measurement. *Permittivity and Measurement*, pp. 3693-3711.
- Shah A., Khan A. K., Chunghtai I. R., Inayat M. H. (2013). Numerical and experimental study of steam water two-phase flow through steam jet pump. *Asia-Pacific Chemical Engineering Journal*, Vol. 8, No. 6, pp. 895-905. <https://doi.org/10.1002/apj.1734>
- Silva D. M. J., Hampel U. (2013). Capacitance wire-mesh sensor applied for the visualization of three-phase gas-liquid-liquid flows. *Flow Measurements and Instrumentation Journal*, Vol. 34, pp. 113-117. <https://doi.org/10.1016/j.flowmeasinst.2013.09.004>
- Strazza D., Demorib M., Ferrari V., Poesio P. (2011). Capacitance sensor for hold-up measurement in high-viscous-oil/ conductive-water core-annular flows. *Flow Measurement and Instrumentation Journal*, Vol. 22, No. 5, pp. 360-369. <https://doi.org/10.1016/j.flowmeasinst.2011.04.008>

- Tan C., Dai W., Wu H., Dong F. (2014). A conductance ring coupled cone meter for oil-water two-phase flow measurement. *Sensors*, Vol. 14, No. 4, pp. 1244-1252. <https://doi.org/10.1109/JSEN.2013.2294629>
- Tan C., Wu H., Dong F. (2013). Horizontal oil-water two-phase flow measurement sensor and cone meter. *Flow Measurement and Instrumentation*, Vol. 34, pp. 83-90. <https://doi.org/10.1016/j.flowmeasinst.2013.08.006>
- Thorn R., Johansen G. A., Hammer E. A. (1997). Recent developments in three-phase flow measurement. *Measurement Science and Technology*, Vol. 8, pp. 691-701. <https://doi.org/10.1088/0957-0233/8/7/001/meta>
- Wang Z. Y., Jin N. D., Gao Z. K., Zong Y. B., Wang T. (2010). Nonlinear dynamical oil-gas-water three-phase flow pattern characteristics. *Chemical Engineering Science*, Vol. 65, No. 18, pp. 5226-5236. <https://doi.org/10.1016/j.ces.2010.06.026>

