



## LJMU Research Online

Papagiannis, F

**“National Patient Flow Framework: An ontological Patient-oriented Redesign**

<http://researchonline.ljmu.ac.uk/id/eprint/937/>

### Article

**Citation** (please note it is advisable to refer to the publisher’s version if you intend to cite from this work)

**Papagiannis, F (2015) “National Patient Flow Framework: An ontological Patient-oriented Redesign. Healthcare Information Management & Communications Canada.**

LJMU has developed [LJMU Research Online](#) for users to access the research output of the University more effectively. Copyright © and Moral Rights for the papers on this site are retained by the individual authors and/or other copyright owners. Users may download and/or print one copy of any article(s) in LJMU Research Online to facilitate their private study or for non-commercial research. You may not engage in further distribution of the material or use it for any profit-making activities or any commercial gain.

The version presented here may differ from the published version or from the version of the record. Please see the repository URL above for details on accessing the published version and note that access may require a subscription.

For more information please contact [researchonline@ljmu.ac.uk](mailto:researchonline@ljmu.ac.uk)

<http://researchonline.ljmu.ac.uk/>

October 2010

# National Patient Flow Framework: An Ontological Patient-Oriented Redesign

Fragoulis PAPAGIANNIS <sup>a, b</sup>, Abdul ROUDSARI <sup>b, c</sup> and Konstantinos DANAS <sup>d</sup>  
*<sup>a</sup> American College of Thessaloniki, Greece, <sup>b</sup> Centre for Health Informatics,  
City University, UK, <sup>c</sup> School of Health Information Science, Victoria University,  
Canada, <sup>d</sup> School of Computing, IS and Mathematics, Kingston University, UK*

**Abstract.** This study introduces the necessary ontological redesign regarding patient-oriented frameworks. Different national healthcare frameworks around the world as well as semantic gaps have been discovered and demonstrate the need for a new healthcare management framework. This study's Patient-Oriented Management and Reporting framework (POMR framework) will introduce and measure the concept of value-added, patient-oriented flow. The ontological introduction of leading patient-oriented measures is also considered as a novel approach to solving problems. These measures are included in this POMR framework which introduces a unique ontological model redesign (POMR model) and its patient-oriented supporting information system (POMRS) adding value to the concept's implementation in CLIPS technology.

**Keywords.** Patient-oriented, ontology, framework, measures, redesign

## 1. Introduction

Most of the contemporary studies focus on the redesign and optimisation of the patient flow without consideration of this study's conceptual framework. This study focuses on specific patient flow transactions and measures that should be encompassed within the patient flow framework that is designed. The contemporary healthcare at the national level would thus be redesigned around patient needs. This study will focus on the Greek patients as they are paying the most out of their pockets (OECD, 2006). Greece's single payer system's aim should be equally available for everyone delivering effectiveness and efficient performance (Tountas and Economou, 2007). Other relevant research provides, as well, sufficient evidence of the need for an alternative patient oriented flow in the country (Pananikolaou, Ntani, 2008). Based on enterprise ontology

*October 2010*

this study will redesign the core patient flow processes. Simultaneous introduction of a patient-oriented model and its supporting information system will conceptualise and implement this ontological framework aiming towards the quantity and quality flow redesign and basic information exchange. This study also aims at fulfilling the NHS objectives, if in existence, with regard to patient-centred care.

## **2. Method**

This research problem is defined as: “The contemporary lack of patient-oriented external parameters and internal transactions that guide and measure the quality service of the patient flow primarily within the healthcare premises that currently lead to lack of patient satisfaction, treatment and high hospitalisation costs.” The solution to that problem concerns an intervention in the problematic areas of the patient flow process as far as patient value-added is concerned, based on a proposed Object System (OS) or rather POMR framework. The terms OS and POMR framework might be considered for the purpose of this study almost identical to the degree that framework is considered as a re-usable measurable design for this study’s proposed OS (Papagiannis et al., 2005). Proactive transactions in healthcare could develop the Using System (US) to deliver patient satisfaction outcomes for the healthcare organisations to study in order to remain competitive (Steinke et al., 2003). The DEMO redesign methodology is selected since based on enterprise multilayer structure, it develops a framework that bridges mostly semantic gaps between technical and social issues which are very important according to the literature review for the nature of this study. So, developing an OS is to define, at the ontological level, the prototype model (POMR) and next its supporting information system (POMRS) to this model of a world that assists the framework’s concept at info-logical and data-logical level.

## **3. Analysis**

Based on Dietz’s ontology (2006) this redesign study follows these methodology steps:

1. Requirement analysis for the US with the White Box model (WB model)
2. Structural decomposition of the US with the WB model
3. Identification of the Black Box model’s redesigning requirements (BB model input)
4. Redesigning of the specifications of the results and measures function (BB output)
5. Devising specification of the OS with the WB model
6. Redesigning and implementation of the OS with CLIPS technology

*Step 1: Requirement analysis for the US with the WB model*

The framework figure produced next should encompass the POMRS, its infrastructure and POMR model for the implementation of a patient-oriented flow concept:

October 2010

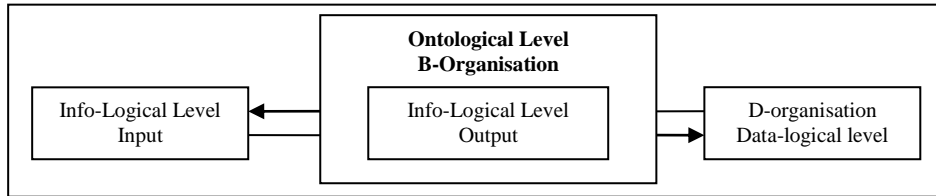

**Figure 1:** Framework infrastructure of the OS

*Step2: Structural decomposition of the US with the WB model*

The process of the patient flow based on the WB devising processes and research findings is having four core US sub-processes: P01: Patient appointment to GP, P02: Patient referral process, P03: The contemporary treatment process, P04: The discharge process. These sub-processes need to be redesigned. The US of the P02 ontological diagram (Figure 2) is produced in enterprise ontology software design package: Xemod 2008.

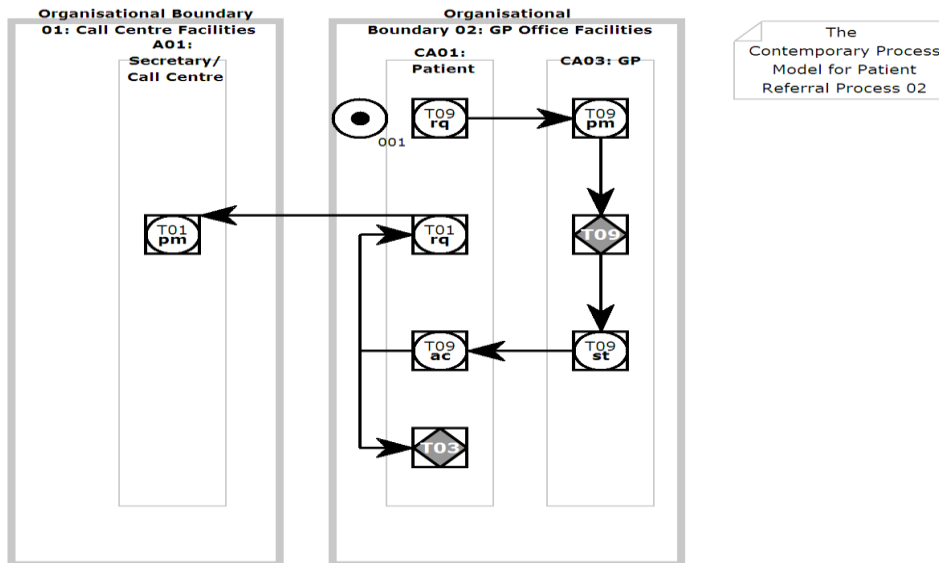

**Figure 2:** The US process 02 model of the contemporary situation

*Step 3: Identification of the Black Box model's redesigning requirements (BB model input)*

Based on Figure 2, the US process from the examination results acceptance of the patient (T10 acceptance) is haphazard as there are multiple choices due to lack of policies and procedures from all the previous systems gaps presented in this section. Thus a measurable transaction structure that focuses on the patient relation rather than patient transaction should be redesigned. All other transactions to be followed in the

October 2010

patient's flow, at primary level, are based on the doctor's decision-making process which is taking place solely on doctor's tacit knowledge. Thus the US process 02 (Figure 2) requires the abolishment of the current series of multiple appointments and time spent by the patient before the process completion. That is why the Figure 2 ends with the initiation of a loop for the first contemporary process (P01). Thus, it is imperative that patient's choice to be supported by value-added information, as patients should pay for results and not for procedures.

*Step 4: Redesigning of the specifications of the results and measures function*

The following transactions are being redesigned, as Table 1 indicates, providing relative measurable results. These results are produced in a unique primary, secondary and tertiary level hierarchy, and should be introduced to support these ontological transactions at all levels. These core patient flow transactions' results to specific process steps delivered through the construction and organisational synthesis.

**Table 1:** The TRT of the proposed patient flow

<b>Transaction Type</b>	<b>Transaction Result</b>
T1 Healthcare appointment management	R1 Initiation of a patient relationship management
T2 E P R analysis	R2 Complete patient record
T3 Doctor's referral for further treatment	R3 Patient treatment proposal based on POMR2
T4 Hospital inflow	R4 Patient-oriented hospital registration And room allocation
T5 Hospital discharge and/or rehabilitation treatment initiation	R5 Patient treatment and/or outpatient hospital rehabilitation procedures report program
T6 Patient relationship monitoring	R6 Verification of rehabilitation procedures and delivery of POMR1, POMR4
T7 Patient record management	R7 Storage, indexing, retrieval of patient records
T8 Information retrieval from NHS bill of examination database	R8 Interpret information based on expertise
T9 Patient Examination	R9 Diagnosis of the patient's problem
T10 Patient-oriented measurements analysis for patient condition	R10 Treatment proposal based on relevant POMR3
T11 Initiation of patient's treatment circle	R11 Patient POMR based counselling
T12 Electronic study management treatment	R12 Electronic verification of treatment process and medical operations
T13 Proactive treatment continuation	R13 Prevention plan.
T14 Doctor's expert opinion	R14 Patient quality communication
T15 Laboratory tests	R15 Safe laboratory results
T16 Clinical tests	R16 Safe clinical results
T17 Electronically recorded treatment performance	R17 Patient's awareness of medical performance
T18 Electronically recorded narration of treatment methodology	R18 Patient's awareness of the full treatment circle

October 2010

*Step 5: Division of the specifications of the OS with the WB model*

The first of these sets of measures will focus on equal patient access via accessibility function of the healthcare system. The next two sets of measures will focus on efficiency via the safety function and structural operation function. The last set focuses on effectiveness via the outcome function. So, several measures are included in such coded reports as Figure 3 exhibits, at info-logical level for the supporting POMRS. Next, at data-logical level, object model coding is in order. An indicated report coded as Patient-Oriented Measurement Report number one (POMR1), is exhibited:

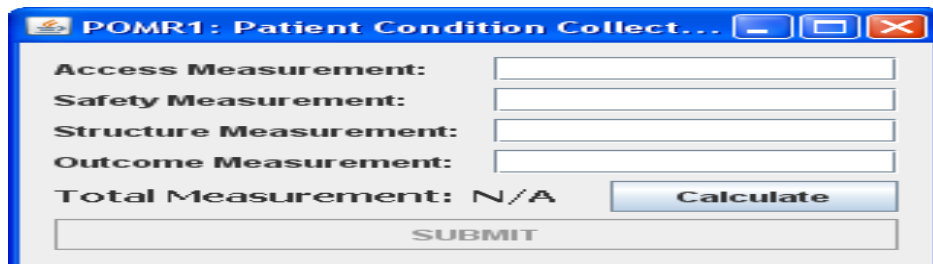

The screenshot shows a software window titled "POMR1: Patient Condition Collect...". Inside the window, there are four rows of input fields, each preceded by a label: "Access Measurement:", "Safety Measurement:", "Structure Measurement:", and "Outcome Measurement:". Below these fields, the text "Total Measurement: N/A" is displayed, followed by a "Calculate" button. At the very bottom of the window is a "SUBMIT" button.

**Figure 3:** "POMR1: patient condition collection measure" screen

*Step 6: Redesigning and implementation of the OS with CLIPS technology*

The OS P02 process follows the OS P01 process. As the GP's assistance prepares for the appointment, the patient has a good chance to proceed efficiently for further treatment. Any other referrals that are not relevant to extraordinary ad hoc patient conditions are considered evidence towards ineffective P01 according to the following measure which is included in the POMR1 report (Figure 3):

- **Referral measure (n) = S (n) T03 / S (n) T04                      Eq. (1)**

Where n equals number of instances in integer numbers (example: "patient condition"). Upon successful loading of the ontological model's processes knowledge base on CLIPS the rule base is launched and implementation occurs.

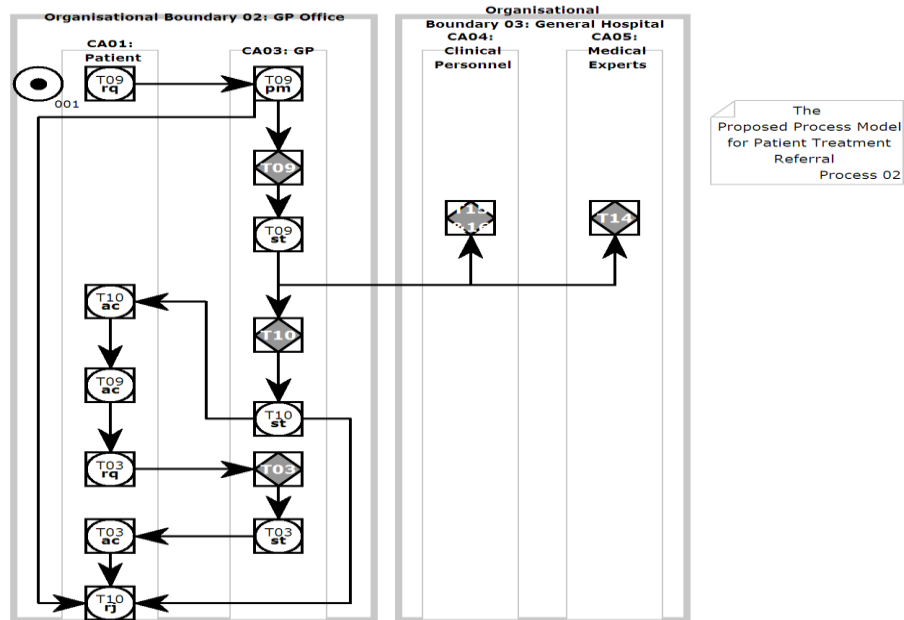

Figure 4: The OS process 02 model of the proposed situation

#### 4. Conclusions

This study’s framework introduced a measurable value-added patient flow. According to this novel redesign, the patient proceeds in a patient-oriented way which is specified by the enterprise ontology processes and transactions introduced. The ontological rules which govern this flow are designed in Xemod and encompassed in a CLIPS knowledge base in order to implement this redesigned flow. The results of the flow of each patient entity are being monitored, stored and evaluated accordingly by the system’s actors.

#### References

- [1] Dietz, J.L.G. (2006). *Enterprise Ontology*. Heidelberg, Germany Springer-Verlag
- [2] OECD (2002), “Measuring up: Improving health system performance in OECD system performance in OECD countries,” Ottawa, Paris November 2001, Conference Proceedings Section A-4, pp. 5-7.
- [3] Papagiannis, F., Danas, K., Roudsari, A. (2005), “Restructuring of The Health Care Sector: A Patient-oriented Approach,” Proceedings of the 10<sup>th</sup> ISIMR 2005, Thessaloniki, Greece.
- [4] Papanikolaou, V., Ntani, S. (2008), “Addressing the Paradoxes of Satisfaction with Hospital Care,” *International Journal of Health Care Quality Assurance*, Vol. 21 No 6, pp.548-561
- [5] Steinke, G., Nickolette, C. (2003), “Business rules as the basis of an organisations information systems,” *Industrial Management and Data Systems*, Vol. 103/1, pp. 52-63
- [6] Tountas Y, Economou N. (2007), “Health services and health systems Evaluation,” *Archives of Hellenic medicine*, Vol. 24, pp. 7-21