

THE BIOMECHANICAL MECHANISMS OF FALL RISK ON STAIRS WITH INCONSISTENT STEP DIMENSIONS

Natasha Carrie Francksen

A thesis submitted in partial fulfilment of the requirements of Liverpool John Moores
University for the degree of Doctor of Philosophy

October 2020

Contents

Abstract	6
Declaration	9
Acknowledgements	10
Abbreviations	12
List of Figures	13
List of Tables	20
Chapter 1: General Introduction	21
1.1 Impact of Falls on Stairs	22
1.2 Task of Negotiating Stairs	22
1.2.1 Stair ascent.....	23
1.2.2 Stair descent.....	24
1.3 Mechanisms of Stair Falls	25
1.3.1 Foot clearance.....	26
1.3.2 Foot contact length.....	26
1.3.3 Loss of CoM control.....	28
1.4 Contributing Factors to Stair Falls	28
1.4.1 Human behaviour.....	28
1.4.2 Environmental factors.....	29
1.5 Stair Dimensions.....	30
1.5.1 Rise dimensions.....	32
1.5.2 Going dimensions.....	33
1.5.3 Inconsistent dimensions.....	34
1.5.4 Current understanding of fall mechanisms on inconsistent stairs.....	35
1.6 Rationale and Aims of Thesis	37
Chapter 2: General Methodology	39
2.1 Introduction	40
2.2 Participants	41
2.2.1 Inclusion criteria.....	41
2.2.2 Exclusion criteria.....	41
2.3 Protocol.....	41
2.4 Instrumentation	44
2.5 Custom Foot Model/Markers.....	45

2.6 Whole-Body Model.....	47
2.7 Data Analysis	48
2.8 Outcome Measures	48
2.9 Statistical Analysis	51
Chapter 3: 52	
Biomechanics of Stepping on Stairs with an Inconsistent Rise	52
3.1 Introduction	53
3.2 Hypothesis 1.....	54
3.3 Hypothesis 2.....	54
3.4 Methods	54
3.4.1 Statistical analysis.....	55
3.5 Results.....	56
3.5.1 Stair ascent.....	56
3.5.2 Ascent secondary analysis.....	58
3.5.3 Stair descent.....	59
3.5.4 Descent secondary analysis.....	61
3.6 Discussion	63
3.6.1 Stair ascent.....	64
3.6.2 Stair descent.....	64
3.6.3 Implications.....	67
3.7 Conclusion.....	68
Chapter 4: 70	
Biomechanics of Stepping on Stairs with an Inconsistent Going.....	70
4.1 Introduction	71
4.2 Hypothesis 1.....	72
4.3 Hypothesis 2.....	73
4.4 Methods.....	73
4.4.1 Statistical analysis.....	74
4.5 Results.....	75
4.5.1 Stair descent.....	75
4.5.2 Stair ascent.....	79
4.6 Discussion	82
4.6.1 Stair descent.....	83

4.6.2 Stair ascent.....	84
4.6.3 Implications.....	85
4.7 Conclusion.....	87
Chapter 5: 88	
The Impact of Inconsistent Step Dimensions on Whole-Body (CoM) Control During Stair Descent.	88
5.1 Introduction	89
5.2 Hypothesis 1.....	91
5.3 Hypothesis 2.....	91
5.4 Methods.....	92
5.4.1 Selection of outcome measures.....	92
5.4.2 Definition and calculation of outcome measures.....	93
5.4.3 Statistical analysis.....	94
5.5 Results.....	94
5.5.1 Inconsistent rise: temporal effects.....	94
5.5.2 Inconsistent rise: biomechanical effects on Step3.....	95
5.5.3 Inconsistent rise: biomechanical effects on Step2.....	96
5.5.4 Inconsistent going: temporal effects	101
5.5.5 Inconsistent going: biomechanical effects of altering foot trajectory prior to contact.....	101
5.6 Discussion	103
5.6.1 Inconsistent smaller rise Step3.....	103
5.6.2 Inconsistent larger rise Step2.....	104
5.6.3 Inconsistent shorter going.....	105
5.6.4 Implications and future study of stair inconsistencies on balance control.....	106
5.7 Conclusion.....	108
Chapter 6: General Discussion	109
6.1 Background	110
6.2 Purpose	110
6.3 Summary of Results.....	110
6.3.1 Inconsistent rise.....	110
6.3.2 Effects of inconsistent rise on balance control	111
6.3.3 Inconsistent going.....	112
6.3.4 Effects of inconsistent going on balance control.....	114

6.4 Identification of the Inconsistencies	115
6.5 Limitations	118
6.6 Recommendations and Future Directions	121
6.7 Changing Behaviour on Stairs	124
6.8 Conclusion.....	126
Appendix A Camera Setup	128
Appendix B Defining Step-Edges	130
Appendix C Anti-Tipping Mechanism for Forceplates	132
Appendix D Table D.1. Comprehensive Data for Consistent Versus Inconsistent Rise Conditions.....	134
Appendix E Table E.1. Comprehensive Data for Consistent Versus Inconsistent Going Conditions.....	135
References	136

Abstract

Stair falls frequently happen, affecting people of all ages and impact on a person's independence. Not only do high rises and shallow goings increase the fall risk but inconsistent dimensions are commonly reported in stair fall investigations. Literature speculates that, the mechanistic reasoning behind these falls occur because individuals do not detect the inconsistency and therefore do not adjust their stepping behaviour. However, these hypotheses are based on observations and assumptions derived from normal stepping behaviour on consistent stairs and have not yet been experimentally tested. Therefore, the purpose of this thesis is to empirically test the mechanisms by which inconsistencies in rise and going dimensions could cause falls in younger and older adults.

Twenty-six younger adults (24 ± 3 y, 1.74 ± 0.09 m, 71.41 ± 11.04 kg) and thirty-two older adults (70 ± 4 y, 1.68 ± 0.08 m, 67.90 ± 14.10 kg) ascended and descended an instrumented staircase in three conditions: 1) consistent dimensions (all steps riser =200 mm and going =250 mm), 2) inconsistent rise (third step was raised 10 mm, causing the fourth step to have 10 mm reduced riser) and 3) inconsistent going (third step was made 10 mm shorter, causing second step to have a 10 mm increased going). Data were collected from 3D motion capture and force plates embedded in the bottom four steps. Data were used to quantify and compare stepping mechanics and centre of mass control in the consistent condition to that in the inconsistent rise and inconsistent going conditions.

In the inconsistent rise condition (Chapter 3), during ascent clearances of both groups were reduced (≈ 9 mm, $F=48.4$, $p=.001$) over the higher step-edge, increasing trip risk. During descent, percentage foot contact lengths decreased ($\approx 2\%$, $F=9.1$, $p=.004$) on the inconsistently higher step for both groups, possibly increasing the risk of a slip. Foot centre of mass (CoM) trajectories during swing prior to contact, revealed that there were no alterations to stepping behaviour prior to contact with the inconsistently higher rise step, causing a magnitude of change that was comparable to the 10 mm manipulation.

In the inconsistent going condition (Chapter 4), during descent percentage foot contact lengths of both groups were not significantly different to the consistent condition ($\approx 1\%$, $F=2.5$, $p=.121$). Foot CoM trajectories during swing confirmed that, individuals changed their stepping behaviour in late swing prior to contact with the shorter step, contradicting previous assumptions. Additionally, younger adults then had reduced clearances over the inconsistently longer step, which could increase their trip risk. During ascent, there were interaction effects detected between stair configurations and age groups. On the shorter step, foot contact lengths were increased for younger adults ($\approx +2.2\%$) and decreased for older adults ($\approx -2.8\%$) (interaction: $F = 8.8$, $p=.004$), this could increase the chances of a miss-step for the older adults. These differences seemed to stem from positioning on the walkway before transition. Younger adults were 8 mm closer to the stairs in their level-ground step, whereas older adults were 14 mm further away in the inconsistent going condition (interaction effect, $p=.048$).

Descending balance parameters were affected by the presence of the inconsistent dimensions (Chapter 5). There were interactions between the CoM accelerations at 23.6%-31.9% and 73.4%-77.0% of stance on Step4 ($p=.008$ and $p=.035$, respectively) prior to contact with the inconsistent shorter going step, balance parameters after contact were minimally affected. Whereas for the inconsistent rise condition, balance was altered at contact with the higher step due to more posteriorly directed forces between 16.5%-22.2% of stance on Step3 ($p=.020$) and higher peak coefficients of friction ($p=.003$), this could increase the risk of slipping during loading. Despite increased loading rates ($p<.001$) and larger vertical CoM accelerations ($p=.016$) at initial contact onto Step2 (longer step down), there were compensations between 13.7%-19.5% of stance on Step2, whereby upward vertical CoM acceleration were increased to regain control before the subsequent step.

Stepping behaviours observed on the inconsistent rise stairs indicate that younger and older adults did not detect the 10 mm difference in step rise, which put them at a higher risk of tripping in ascent and slipping in descent, and further required good reactive balance control to maintain CoM control after contact. The proactive changes to stepping

behaviour and CoM control observed during descent of the inconsistent going stairs, seems to improve stepping mechanics so that minimal adjustments to CoM control are needed after contact. The proactive change is likely dependent on visual detection of the inconsistency. Frailer or distracted individuals may not be able to respond to the inconsistencies in the same way and therefore may have more frequent falls on inconsistent steps.

Declaration

A small portion of the data presented in Chapter 3 was separately analysed and submitted by Denis Holzer a visiting ERASMUS student, for his Master's degree at the German Sport University, Cologne. The thesis titled "Effect of variable staircase dimensions on postural stability during stair negotiation in younger adults" only included the stepping mechanics of the young adult data ascending the consistent and inconsistent rise staircase. This data was included within the joint publication accepted in Applied Ergonomics, Francksen et al. (2020). As Denis developed the Matlab script to determine the foot clearance and percentage foot contact parameters, he will also be included in publications referencing these parameters in the future.

No other portion of work referred to in this thesis has been submitted in support of an application for another degree or qualification of this or any other institute of learning.

Acknowledgements

I am grateful to have such a large network of people with a vested interest in my success, I could not have done this without you. My time at LJMU has provided a fantastic post-graduate experience, where I have blossomed as an academic and started to become a professional, it has been tough, but I am honoured to be part of such an incredible biomechanics team.

Firstly, a massive thank you to Dr Tom O'Brien my director of studies, for providing an open and supportive environment, yet continually challenging me to step out of my comfort zone. Diligently reading and revising my work. Thank you to Prof. Costis Maganaris, for your grounded advice and knowledge throughout. Thank you also to Prof. Mark Hollands for providing the alternative perspective and improving the overall quality of my work.

I would like to thank the other RISCS (Research to Improve Stair Climbing Safety) team and Biomechanics team members for your thoughtful discussions and insights throughout my project. Thank you to Mike Roys for your consultation and advice. Thank you to Dr Mark Robinson, for advising on the SPM analysis. A special thanks goes to Dr Ian Poole, the Senior Lab Technician for his early morning smile, dad type sense of humour, while also helping me pilot, move cameras, test force plates and problem solve on any technical issues on the stairs. Thank you to visiting members Maighread, Leila and Laure who made progress with the handrail trials analysis as a side-line project to this thesis. Thank you to LJMU Doctoral Academy and the SPS office staff, for all the work behind the scenes, keeping us on track.

I would like to thank my participants for without all those wonderful people I would not have this thesis. Thank you to the older adults for returning to the lab to complete my portion of testing after already being mentally and physically challenged for Thijs's project on a previous occasion and for the younger adults, mostly fellow students and lab mates for giving up your valuable time. Héloïse, thanks for tolerating the extremely lengthy pilot sessions.

Thank you to my friends and lab mates both past and present for the happy social times and the studious lab times. Thijs and Denis for help with data collection and queries in processing. Raihana for leading the way and creating a lovely environment to work in, Jasper and Héloïse for sharing a desk and putting up with my spurts of Disney songs. Jenny, Oat, Yaya, Céleste, Carla, Timmion and Cindy for bringing the fun and other topics to talk about. Visiting members, Keiko, Dorro and Sophia for allowing me to play tour guide and leave the lab at a reasonable hour.

I would like to thank all my friends who have always been there for me, whether around the corner, across the country or around the world, sending positive vibes and support. A special thanks to Peppe, Natalie and Emilyn for being awesome. To my Netball family, thanks for keeping me safe and sane. Caroline and Vicki thanks for being the big sisters I never had.

I am forever grateful to my family, for all their love and support while I strive for my goals. I would not have achieved all this without you. To my new Marshall family who have made my transition to the States smooth.

Thank you to my husband Matthew for your devoted love, persistence, nightly/ mid-afternoon skype calls while I was in Liverpool, using your holiday time between classes to visit for as long as possible, for learning to live with me and bringing smiles to each and every day. Thank you for always believing in me, supporting me, and wiping my stress induced tears. You always inspire me to be the best I can be.

Abbreviations

ANOVA	Analysis of Variance
BRE	The Building Research Establishment
BSI	British Standards Institution
CoM	Centre of mass
CoP	Centre of pressure
GRF	Ground reaction forces
HM Government	Her Majesty's Government
NEISS	National Electronic Injury Surveillance System
NFPA	National Fire Prevention Association
NHS	National Health Service
SPM	Statistical parametric mapping
UK	United Kingdom
USA	United States of America

List of Figures

Chapter 1

Figure 1.1. Phases and events of stair ascent, (solid shaded limb) as described by MacFadyen and Winter (1988). ■ = phases for solid shaded limb, □ = phases for unshaded limb, ▣ = phases for both limbs, ▤ = transition between phases and events. (Image adapted from Spanjaard *et al.* (2007). *Note. phases are not accurately time scaled.*

Figure 1.2. Phases and events of stair descent, (solid shaded limb) as described by MacFadyen and Winter (1988). ■ = phases for solid shaded limb, □ = phases for unshaded limb, ▣ = phases for both limbs, ▤ = transition between phases and events. (Image adapted from Spanjaard *et al.* (2007). *Note. phases are not accurately time scaled.*

Figure 1.3. Stair dimension terminology.

Chapter 2

Figure 2.1. The seven-step stairs, integrated with four Kistler force plates in the bottom four steps and three dummy wooden blocks secured into the top three steps. The safety rope seen in the figure was connected to an overhead safety rail. The connector was attached to the participant's safety harness for all trials. The other end of the rope was controlled by a trained member of the team.

Figure 2.2. Figure 2.2. Seven-step stairs, with four force plates located in Step1-4. For the consistent condition, c) all steps had a rise height of 200 mm, a going of 250 mm. A) for the inconsistent rise condition, ir) only Step3 was moved 10 mm upwards, increasing rise to Step3 to 210 mm thus reducing rise to Step4 to 190 mm. B) for the inconsistent going condition, ig) only Step3 was moved 10 mm inwards, increasing Step2 going to 260 mm thus reducing Step3 going to 240 mm, all other steps and pitch remained unaltered.

Figure 2.3. Foot model markers used for foot clearance and percentage foot contact length variables. Including the lateral calcaneus marker placed as close to join of the shoe sole and shoe upper as possible, 1st metatarsal head, 5th metatarsal head, the toe cluster

was used to estimate toe-spring clearance. The shoe outline and marker centres were drawn onto a piece of A4 paper.

Figure 2.4. Adapted plug in gait model, 6 degrees of freedom, defining 15 segments. 76 markers were used in total. Additional markers were used on the head, elbows, pelvis and feet to improve tracking across the whole stair, walkway and landing areas.

Figure 2.5. A) vertical (v) foot clearance in ascent, with toe-spring correction (t) added B) horizontal (h) foot clearance in descent, C) foot contact length percentage in ascent and D) descent; linear horizontal distance of foot over the step (x). linear horizontal distance of foot not over the step (y), as foot may be in plantar flexion.

Chapter 3

Figure 3.1. Seven-step stairs, with four force plates located in Step1-4. For the consistent condition a) all steps had a rise height of 200 mm, a going of 250 mm. For the inconsistent rise condition b) only Step3 was moved 10 mm upwards, increasing rise to Step3 to 210 mm thus reducing rise to Step4 to 190 mm, all other steps and pitch remained unaltered.

Figure 3.2. Stair ascent A), change in vertical foot clearance from the step-edge and B), change in percentage foot contact length on each step, from consistent to inconsistent rise condition (Step3 10 mm higher), a negative value represents a reduction and thus increased level of risk during the inconsistent rise condition compared to the consistent condition. — = No/zero change, X represents group mean, □ = younger adults, □ = older adults. A two by two-repeated mixed methods ANOVA was run on values recorded for foot clearance and foot contact, during the consistent and inconsistent rise conditions for younger and older adults. * = stair condition effect where differences between consistent and inconsistent rise condition exist, + = interaction effects between stair condition and age group; $p < 0.05$, all significance levels reported at the significance level $p \leq 0.05$.

Figure 3.3. Stair ascent, vertical trajectory of the CoM of the foot relative to the total horizontal displacement travelled during swing from toe off Step1 until before touchdown on Step3 (same relative vertical position irrespective of stair dimensions). Trajectories are

shown at 5% intervals. ● = younger adults' consistent condition, ○ = younger adults' inconsistent rise, ▲ = older adults' consistent condition, △ = older adults' inconsistent rise, | = end of SPM analysis (vertically similar point in space). Foot position was only significantly different between condition after 85% of displacement —, $p = .019$ (N = 14 per group). Step3 edge vertical position in consistent condition = 0.401 m and inconsistent condition = 0.412 m.

Figure 3.4. Stair descent A), change in horizontal foot clearance from the step-edge and B), change in percentage foot contact on each step, from consistent to inconsistent rise condition (Step3, 10 mm higher), a negative value represents a reduction and thus increased level of risk during the inconsistent rise condition compared to the consistent condition. — = No/zero change, X represents group mean, □ = younger adults, □ = older adults. A two by two repeated mixed methods ANOVA was run on actual values recorded for foot clearance and foot contact, during the consistent and inconsistent rise conditions for younger and older adults. * = stair condition effect where differences between consistent and inconsistent rise condition exist, + = interaction effects between stair condition and age group; $p < 0.05$, all significance levels reported at the significance level $p \leq 0.05$.

Figure 3.5. Stair descent horizontal and vertical trajectory of the foot CoM. Data are time normalised from toe off Step5 until one frame before contact on Step3, data points are sampled at every 5% of swing. ● = younger adults' (YA) consistent condition, ○ = younger adults' inconsistent rise, ▲ = older adults' (OA) consistent condition, △ = older adults' inconsistent rise, — = end of SPM analysis (similar vertical point in space), — = horizontal position was significantly different between conditions at 9-48% ($p = .006$), — = an age effect was present in horizontal position between 27.8% - 61.5% and after 83.5%, $p < .05$. Vertical position was not significantly different.

Figure 3.6. The effect of repeated trials negotiating stairs with inconsistent rise heights (Step3) on A) young adults' foot clearance in ascent, N = 24; B) older adults' foot clearance in ascent, N = 20 and C) older adults' percentage foot contact during descent, N = 20.

Repeated measures ANOVAs detected no significant differences between repeated rise trials ($p > 0.05$ for all).

Chapter 4

Figure 4.1. Seven-step staircase, with four force plates located in Step1-4. For the consistent condition (a) all steps had a had a going of 250 mm and a rise height of 200 mm, for the inconsistent going condition (b) only Step3 was moved 10 mm inwards, increasing Step2 going to 260 mm and thus reducing Step3 going to 240 mm, all other steps remained the same.

Figure 4.2. Stair descent A) change in horizontal foot clearance from the step-edge and B) change in percentage foot contact length on each step, from consistent to inconsistent going condition (Step3, 10mm shorter), a negative represents a reduction and thus and increased level of risk during the inconsistent going condition compared to the consistent condition. — = No/zero change, X represents group mean, □ = younger adults, □ = older adults. A two by two-repeated mixed methods ANOVA was run on values recorded for foot clearance and foot contact, during the consistent and inconsistent going conditions for younger and older adults. * = stair condition effect where differences between consistent and inconsistent rise condition exist, + = interaction effects between stair condition and age group; $p < 0.05$, all significance levels reported at the significance level $p \leq 0.05$.

Figure 4.3. Stair descent horizontal and vertical trajectory of the foot CoM. Data are time normalised from toe off Step5 until one frame before contact on Step3, data points are sampled at every 5% of swing. —●— = younger adults' (YA) consistent condition, —○— = younger adults' inconsistent going, —▲— = older adults' (OA) consistent condition, —△— = older adults' inconsistent going, — = horizontal position was significantly different between conditions after 78% of swing ($p = .025$), — = an age effect for horizontal position was present between 30-54% and after 75% of swing. Vertical position was not significantly different.

Figure 4.4. Stair descent horizontal and vertical position trajectory of the foot CoM. Data are time normalised from toe off Step3 until contact on Step1, data points are sampled at every 5% of swing. —●— = younger adults' (YA) consistent condition, —○— = younger adults' inconsistent going, —▲— = older adults' (OA) consistent condition, —▲— = older adults' inconsistent going, — = an age effect was present between 16-52% of swing.

Figure 4.5. Stair ascent A) change in horizontal foot clearance from the step-edge and B) change in percentage foot contact length on each step, from consistent to inconsistent going condition (Step3 10 mm shorter), a negative represents a reduction and thus an increased level of risk during the inconsistent condition. percentage change in foot contact on each step, from consistent to inconsistent going condition. — — = No/zero change, X represents group mean, □ = younger adults, □ = older adults. A two by two-repeated mixed methods ANOVA was run on values recorded for foot clearance and foot contact, during the consistent and inconsistent going conditions for younger and older adults. * = stair condition effect where differences between consistent and inconsistent rise condition exist, + = interaction effects between stair condition and age group; $p < 0.05$, all significance levels reported at the significance level $p \leq 0.05$.

Figure 4.6. Stair ascent horizontal and vertical trajectory of the foot CoM. Data are time normalised from toe off from the walkway until one frame before contact on Step2, data points are sampled at every 5% of swing. —●— = younger adults' (YA) consistent condition, —○— = younger adults' inconsistent going, —▲— = older adults' (OA) consistent condition, —▲— = older adults' inconsistent going.

Chapter 5

Figure 5.1. Stance time and single-limb support duration on A) Step4, B) Step3 and C) Step2 for the younger (YA) and older adults (OA) in the consistent and rise conditions. * indicates a condition effect between stairs, for single limb support and reduced stance time, → indicates direction and condition effect for gait event timings, $p < .05$. Note: stance time was ~ 0.67 s for all steps in the consistent condition and was only significantly

reduced in the inconsistent rise condition on Step2 (Part C) by 0.02 s for the younger adults and 0.01 s for the older adults.

Figure 5.2. Step3 instantaneous data including: A) downward centre of mass (CoM) velocity 1 frame before contact on Step3, B) Vertical loading rate relative to body mass on Step3, calculated between 10-90% of the first vertical ground reaction force peak C) Peak required coefficient friction in the loading phase on Step3. * Condition effect $p < .05$, + condition by age interaction $p < .05$.

Figure 5.3. Step3 data curves normalised to 100% of stance on Step3 including: A) Vertical ground reaction forces (GRF) normalised to bodyweight (BW), B) Anterior-posterior GRF normalised to BW (anterior forces are positive), C) horizontal distance between centre of pressure (CoP) and Step3 edge, D) horizontal distance between whole body centre of mass (CoM) position. Data are sampled at 5% increments and significant condition effects are indicated to the nearest 5% (blue line) with an individualised p values within the figure. Age effects with $p < 0.05$ are presented with a green line and do not have individualised p values within the figure.

Figure 5.4. Step2 data including instantaneous data A-B and Data curves normalised to 100% of stance on Step2 C-F. A) Instantaneous downward centre of mass (CoM) velocity 1 frame before contact on Step2, B) Vertical loading rate relative to body mass on Step2, calculated between 10-90% of the first vertical ground reaction force peak. Data curves were sampled at 5% increments and included C) Vertical ground reaction forces (GRF) normalised to bodyweight (BW), B) Vertical ground reaction forces (GRF) normalised to bodyweight (BW), C) Anterior-posterior GRF normalised to BW (anterior forces are positive), D) horizontal distance between centre of pressure (CoP) and Step3 edge. E) horizontal distance between whole body centre of mass (CoM) position. Significant condition effects are indicated to the nearest 5% (blue line) with an individualised p values within the figure. Age effects with $p < 0.05$ are presented with a green line and do not have individualised p values within the figure. An interaction effect was only found at initial contact in Part D.

Figure 5.5. Inconsistent going condition compared to consistent condition for younger (YA) and older adults (OA). Data curves were sampled at 5% increments and included A) vertical CoM acceleration during stance on Step4, B) horizontal distance between CoM and CoP position on Step3, C) horizontal distance between CoP and Step3 edge. Significant condition effects are indicated to the nearest 5% (blue line) with an individualised p values within the figure and Interaction effects (red lines) were present in the vertical CoM acceleration. Age effects with $p < 0.05$ are represented with a green line and do not have individualised p values within the figure.

Chapter 6

Figure 6.1. Panel A and B shows the ascending view of the stairs from the walkway and Panel C shows the descending view of the stairs from the landing with consistent dimensions, A) has only the riser of Step3 and Step4 highlighted, B) has only the going of Step2 and Step3 highlighted. C) has only the going of Step3 and Step2 highlighted. These highlighted sections would be the only places to observe the inconsistent dimension changes that were used for this study.

Appendices

Figure A.1. Example of camera views used in template for camera setup for A) a camera positioned far away from the stairs and B) a camera positioned closer to the stairs. Notations are added for convenience, ■ Indicates masked areas and ✦ indicates reflective markers.

Figure B.1. Step-edge cluster prototype.

Figure B.2. 3D printed step-edge clusters.

Figure B.3. Visual 3D capture of the step-edge markers and calibration wand defining the global origin.

Figure C.1. Installation of anti-tipping mechanism for user's safety, A) initial mechanism, B) installation process, involving cutting out of wooden material to allow new anti-tipping bracket to be fitted in to the step C) new spring-loaded bracket installed.

Figure C.2. Cross section of step and anti-tipping spring mechanism.

List of Tables

Appendices

Table D.1. Comprehensive Data for Consistent Versus Inconsistent Rise Conditions.

Table E.1. Comprehensive Data for Consistent Versus Inconsistent Going Conditions.

Chapter 1: General Introduction

Stair falls and the influence of stair structure, human movement and why inconsistent dimensions are dangerous

1.1 Impact of Falls on Stairs

For many, being able to negotiate stairs is a necessary part of independent life, since it is required to move around the home, workplace or to access social activities. However, there are reports of frequent falls, since the 1970s (Templer, Mullet, Archea, & Margulis, 1978) when stair safety was identified as an important issue and is still a problem today (Kelsey, Procter-Gray, Hannan, & Li, 2012; Lawrence, Spicer, & Miller, 2014). Stair falls affects people of all ages (Blazewick, Chounthirath, Hodges, Collins, & Smith, 2018; Jacobs, 2016; Lawrence et al., 2014). In 2009 the National Electronic Injury Surveillance System (NEISS) reported over a 12 year period, an increase of approximately 15,000 falls on home stairs for individuals over 65 per year and an increase of approximately 10,000 for other age groups (reported in Johnson and Pauls, 2010). Despite efforts to reduce the number of stair falls, falls continue to cause a significant burden to healthcare services, society and can negatively impact an individual's independence (Jacobs, 2016). An estimated 10% of all stairway falls lead to fatalities (Startzell, Owens, Mulfinger, & Cavanagh, 2000).

In one hospital admission study, over a third of stair fallers who suffered a fracture were over 65 years of age (Mitchell, Aitken, & Court-Brown, 2013). In another, 1,680 falls were reported for older adults in almost three years, 239 of those falls (14.2%) occurred while negotiating stairs, with half of those cases (7.1%) being self-reported as injurious (Duckham et al., 2013). When multiple hospitals are considered the injury rates substantially increase and will continue to do so as population increases (Blazewick et al., 2018). In 2010, stair falls in the USA were estimated to cost over \$92 billion per year (Lawrence et al., 2014), therefore more needs to be done to understand the causes of stair falls and prevent or reduce the incidence rate.

1.2 Task of Negotiating Stairs

Compared to level walking, stair ascent is more demanding for individuals and requires greater concentric contraction (shortening) force from muscles to raise the body's centre of mass (CoM) against gravity, whereas descent is more demanding because

the muscles must eccentrically contract (lengthen) while resisting the pull of gravity, as well as maintain balance during the lowering of the body's CoM to the next step. The most common technique used by healthy individuals is the step-over-step method (King, Underdown, Reeves, Baltzopoulos, & Maganaris, 2018), where only one foot is placed on each step surface and the contralateral foot swings past it to the next available surface (Templer, 1992). It requires alternation between limbs whereby each limb must contribute to single limb support, this is thought to be the fastest and most efficient technique but also the most demanding (King et al., 2018) and will therefore be the focus of the current research project.

1.2.1 Stair ascent.

The action of ascending stairs requires the body's CoM to be moved vertically upwards and forwards onto each step surface. It has periods of double and single limb support and cycles through specific events and phases. There is some variation in terminology used in the literature to describe the phases and key events of stair ascent using a step-over-step technique. Figure 1.1 presents the way stair ascent phases will be defined in this thesis. The first double-support and stance phase are initiated when initial contact is made by the lead limb (black shaded limb in Figure 1.1). Stance according to McFadyen and Winter (1988) is comprised of three sub phases; weight acceptance, pull up and forward continuance. Weight acceptance begins when the weight is shifted off the lower contralateral limb (unshaded limb in Figure 1.1) and is loaded onto the higher lead limb. The lead limb begins to extend and then the contralateral limb is lifted off the lower step initiating single limb support and the pull up phase. During forward continuance, the contralateral limb is swung forwards past the limb in stance and becomes the new lead limb. This limb contacts the step starting the next double support and weight acceptance phase. Meanwhile the now trailing limb flexes at the hip and the knee and plantar flexes at the ankle to initiate toe-off and enters the swing phase which comprises of two sub phases: foot clearance and foot contact. The foot is lifted and must clear the step-edge already occupied by the contralateral limb and the next higher step-edge (foot clearance)

and finally is placed on the higher step surface (foot contact), the cycle continues until the landing is reached (McFadyen & Winter, 1988; Templer, 1992).

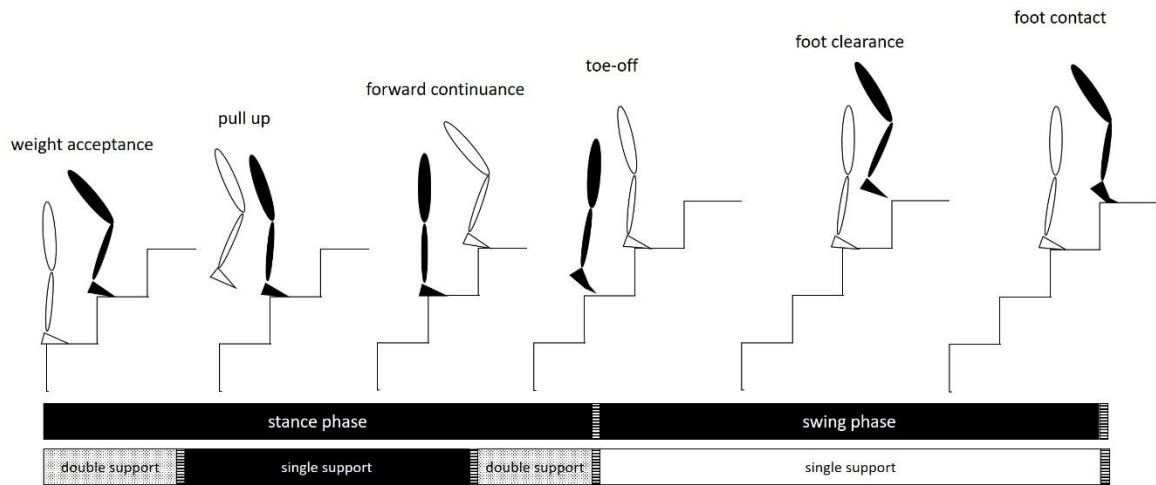

Figure 1.1. Phases and events of stair ascent, (solid shaded limb) as described by MacFadyen and Winter (1988). ■ = phases for solid shaded limb, □ = phases for unshaded limb, ▨ = phases for both limbs, ▩ = transition between phases and events. (Image adapted from Spanjaard *et al.* (2007). *Note. phases are not accurately time scaled.*

1.2.2 Stair descent.

The action of stair descent requires a controlled lowering of the CoM onto each step surface, while maintaining appropriately paced forwards progression. Like stair ascent, descent can be conceptualised as being divided into sub phases, which are defined in Figure 1.2. Stance includes weight acceptance, forward continuance and controlled lowering. The lead limb makes initial contact with the step (shaded limb in Figure 1.2) and begins double support and weight acceptance, where weight is shifted from the contralateral trailing limb (unshaded limb in Figure 1.2) and the lead limb is loaded. The lead limb supports all the weight as single limb support is initiated and the contralateral limb lifts off the step. The contralateral limb is then brought forwards passing the stance limb to become the new lead limb (forward continuance). The now trailing limb flexes at the hip, knee and ankle to lower the CoM and contralateral limb to the next step (controlled lowering) where it makes contact and commences double support and its own weight acceptance phase. Meanwhile weight shifts from the now trailing limb forwards onto the contralateral limb. Single limb support for the contralateral limb commences as

the trailing limb lifts off (toe-off) the step and enters the swing phase. The swing phase consists of the leg pull through and foot contact phases (McFadyen & Winter, 1988). During the leg pull through the swing limb must clear the step-edge that it had just left, pass the contralateral stance limb and the next step-edge, where the swing limb becomes the lead limb again. Finally, the foot is positioned over the next step surface before contact (foot contact) is made and the cycle repeats.

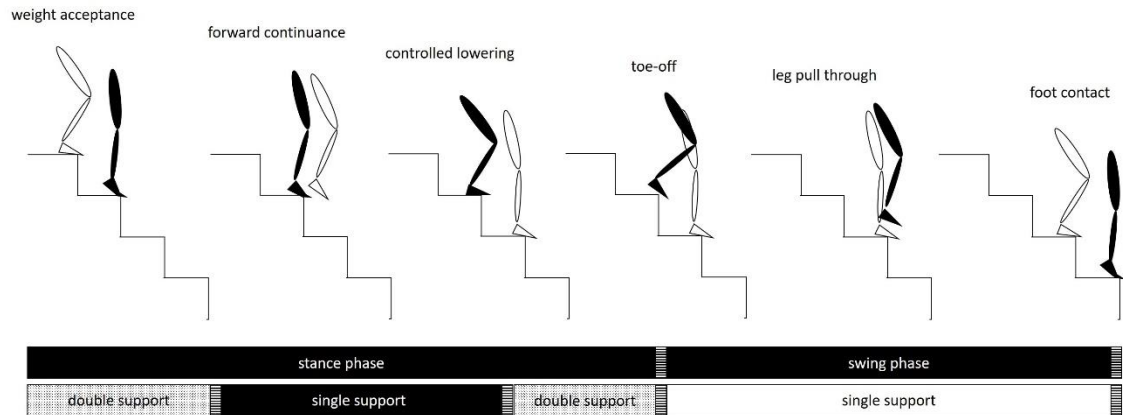

Figure 1.2. Phases and events of stair descent, (solid shaded limb) as described by McFadyen and Winter (1988). ■ = phases for solid shaded limb, □ = phases for unshaded limb, ▨ = phases for both limbs, ▩ = transition between phases and events. (Image adapted from Spanjaard *et al.* (2007). *Note. phases are not accurately time scaled.*

1.3 Mechanisms of Stair Falls

The safety of stair negotiation depends on the interactions between the behaviour of humans and their environment. These interactions can be complex and occur in very many ways, but in combination they lead to falls either because the base of support offered by the foot is compromised or there is a loss of control of the CoM. The following sections will introduce the mechanisms of each type of stair fall which can be caused by perturbations to the trajectory of the foot due to inadequate foot clearances (section 1.3.1), placement of the foot on each step surface (section 1.3.2), and a loss of balance control. Due to the complex coordination required to negotiate stairs balance control can be perturbed independently from the foot behaviour (section 1.3.3). The subsequent

section (section 1.4) will then discuss the interactions of human movement and the environment and how they may contribute to these mechanisms of falls.

1.3.1 Foot clearance.

It is important to maintain good foot clearances from the step-edges in stair negotiation. When there is no foot clearance in ascent, the toe area will contact the step-edge causing a trip which may lead to a forwards fall (Templer, 1992). When there is no foot clearance in descent, the heel or the toe area will catch on the step-edges possibly interrupting CoM control (Templer, 1992) and may also affect subsequent foot placement and contact. During descent, Telonio and colleagues, found that the heel sole area was likely to have the smallest foot clearances (69%) from the step-edges compared to the forefoot (14%) and midfoot (17%) regions of the foot.

The chances of tripping increase when individuals either have lower mean clearances or larger variability in those clearances, such as those reported for older adults compared to young adults (Hamel, Okita, Higginson, & Cavanagh, 2005). Whereas, frailer older adults have shown reduced clearances compared to those of healthy older adults (Zietz, Johannsen, & Hollands, 2011). Increased variability and low clearances put both groups of older adults more at risk of experiencing a trip. Hamel et al (2005) found that on 7% of occasions, minimal foot clearance was less than 5 mm for the older adults (Hamel, Okita, Bus, & Cavanagh, 2005), this means, the foot came extremely close to tripping and any errors in stepping movements would probably cause a toe catch or heel catch event which could result in a fall and may have serious consequences for the individual.

1.3.2 Foot contact length.

There must be enough of the foot on the step surface to provide an adequate base of support for the CoM movement and resist the frictional forces imposed upon it. Under-stepping is mostly likely to occur in ascent and over-stepping is more likely to occur in descent (Templer, 1992). The risk of under-stepping in ascent arises when too little of the forefoot is placed on the step, or when the step is missed completely (Roys, 2013). The

distance between the centre of the ankle joint and the centre of pressure (CoP), in other words, the moment arm length of the ground reaction force (GRF), is also increased, thus the plantar flexor muscles must generate more force to raise the CoM upwards. This is more likely to be a problem for older adults who have reductions in maximal strength capacities (Pijnappels, van der Burg, Reeves, & van Dieën, 2008; Tiedemann, Sherrington, & Lord, 2007) and who have already been reported to adjust moment arms to minimise ankle moments and redistribute some of the load towards the knee (Reeves, Spanjaard, Mohagheghi, Baltzopoulos, & Maganaris, 2008b). Too much demand on the ankle musculature may result in failure, loss of footing and may cause a loss of balance.

The proportion of foot in contact with the step surface during descent is considered more important than ascent for safe stair negotiation (Roys, 2013), as those habitually stepping with greater overhang are more likely to experience a fall than those with a greater proportion of their foot on the step (Roys & Wright, 2005). The risk of overstepping increases on narrower stairs, due to lack of space to place the foot safely (Wright & Roys, 2005). This causes the CoP to be closer to the step-edge, which could result in a slip during the weight acceptance phase. There is also less surface area for proprioceptive feedback and less distance over which the CoM can be slowed and controlled during controlled lowering before contact with the next step can occur. If more than 30% of the foot overhangs the step on a habitual basis, there is an increased risk of a slip over the step-edge (Roys, 2013), however the British Standards Institution (BSI) indicate that 50-60% of overhang would most likely lead to a fall (BSI, 2010). Inappropriate foot placements may lead to slips from poor frictional parameters or may inhibit effective force absorption at each initial contact and weight acceptance phase, consequently the CoM velocities and accelerations increase exponentially (Buckley, Cooper, Maganaris, & Reeves, 2013; Mian, Narici, Minetti, & Baltzopoulos, 2007), possibly to a point where they cannot be controlled.

1.3.3 Loss of CoM control.

Not only can minimal foot clearances and small foot contact lengths cause circumstances where the CoM is perturbed and thus may cause a fall, but CoM control on stairs can be compromised by many additional reasons. Stair descent is considered more demanding and dangerous than ascent, CoM must be repeatedly moved out of a small base of support (defined by the step-edges), causing periods of instability within every step. Greater distances between CoM and the CoP, reflect more instability (Zachazewski, Riley, & Krebs, 1993), but small distances between the CoM and step-edge during in the weight acceptance phase could be particularly dangerous as any errors in movement or failure of the muscles to absorb the forces may result in a irretrievable loss of balance.

The ability to maintain good control over the CoM during stair negotiation is imperative to maintain safety (Buckley et al., 2013; Mian et al., 2007). It requires information from multiple body systems to be integrated together, interpreted and actioned appropriately, for example combining information from the visual, somatosensory and vestibular systems to enable monitoring of the angles, accelerations and position of limbs within the environment. Stair negotiation causes a continually changing environment that has to be monitored relative to a predefined motor plan and adjusted accordingly to proprioceptive feedback on each step.

1.4 Contributing Factors to Stair Falls

The risk of having a fall on stairs caused by the previously mentioned mechanisms, can be increased by certain behaviours of the individual, factors within the environment or the interaction between the two making the negotiation riskier and potentially unsafe.

1.4.1 Human behaviour.

Many behavioural factors that can contribute to an increased fall risk on stairs and were documented in early stair research videos (Templer et al., 1978) and include: rushing, not holding the handrails, being distracted by people or the environment, avoiding obstacles, not wearing appropriate footwear. These factors can all increase

variability in human stair movement and may cause missteps by altered clearances, foot positioning or pose challenges to CoM control. In addition, humans often take for granted how dangerous stairs can be. Hay and Barkow (1985) (as described in Templer, 1992), noted that there are flaws in humans' assumptions and expectations, such that, stairs are engineered therefore, they must be engineered correctly. People do not behave as cautiously as they should when negotiating stairs, which contributes to put them at greater risk of experiencing a fall.

Recent research has found that a group of healthy older and younger adults could be grouped by certain combinations of risky and safer stepping characteristics rather than just by their age. For example, one group identified from the cohort (including both younger and older adults) negotiated stairs considerably faster than other groups, which is considered riskier, this group also had a lower required coefficient of friction which is considered safer (Ackermans et al., 2019). Individuals from this study seemed to balance riskier behaviours with something that was slightly safer. In other studies, it has been reported that, older adults adapted their stepping strategy to suite their own capacities, such as putting more muscular demand on the posterior limb during decent compared to younger adults to stay within their own maximal limits (Reeves et al., 2008b; Reeves, Spanjaard, Mohagheghi, Baltzopoulos, & Maganaris, 2009). Typically healthy older adults tend to have increases in clearances but larger variability in their stepping behaviour compared to younger adults, whereas high risk older adults have considerably reduced clearances (Zietz et al., 2011), which put them at greater risk of an incident. Irrespective of how humans behave there are certain environmental factors which may increase the risk of a fall on stairs.

1.4.2 Environmental factors.

The environmental factors of and around the staircase, play an important role in the level of risk posed by negotiating them. Importantly, these are factors that an individual cannot control or avoid in that precise moment and therefore will affect the

safety of everyone who negotiates those stairs. Therefore, safety on a given staircase relies on good design, proper construction and appropriate maintenance.

In addition to the design and dimensions of the steps, which will be described in detail below, the environment surrounding the stairs is also important. Stairs should be free from obstructions, low beams, distracting views or anything that would impinge on safe stair movement (Templer et al., 1978) and might cause a person to adjust their body position anywhere on the stairs. Secure and properly fitted handrails can improve safety by enabling the redistribution of joint moments away from the lower-limbs and improve stability, when they are used (Reeves, Spanjaard, Mohagheghi, Baltzopoulos, & Maganaris, 2008a). A handrail is also a useful tool for helping arresting a slip (Gosine, Komisar, & Novak, 2019) or a trip. In the 12 month follow up data of Ackermans, the only group not to experience falls on the stairs were the individuals already identified with balance issues and thus were habitually dependent handrail users on the stairs (Ackermans, 2019; Ackermans et al., 2020).

Research has noted the importance of foveal (Den Otter, Hoogwerf, & Van Der Woude, 2011; Miyasike-Dasilva, Allard, & McIlroy, 2011; Zietz & Hollands, 2009) and peripheral (Timmis, Bennett, & Buckley, 2009) vision in guiding stepping behaviour so it unsurprising that well defined step-edges are also imperative for safety. They allow increased foot clearances, better foot placements (Foster, Hotchkiss, Buckley, & Elliott, 2014) and improved balance control (Zietz et al., 2011). Step-edge contrast can be improved with good lighting conditions, which have shown reduced movement variability (Hamel, Okita, Higginson, et al., 2005), improved stepping behaviours and increased confidence levels in older adults as they negotiate stairs compared when they did so in darker conditions (Thomas et al., 2020).

1.5 Stair Dimensions

Many environmental factors can be changed, however the original dimensions of the staircase design and construction are not easily changeable but are important in determining fall risk (Roys, 2001, 2013; Templer, 1992). Therefore, building regulations

govern the permitted stair dimensions, including the rise (the vertical distance between each step), going or tread depth (the horizontal distance available on the stepping surface) and the overall pitch (Figure 1.3). In the UK, the building regulations state that the riser must be between 150 mm – 220 mm for homes and for public stairs between 150 mm – 170 mm. The going dimensions in the home should be between 220 mm – 400 mm and for public stairs a minimum going of 250 mm is required. The combination of rise and going dimensions must not exceed a pitch of 42° (Figure 1.3, HM Government, 2000, 2013).

Unfortunately, the building industry often installs the most cost-effective stairs, those taking up the smallest amount of floor space, or prioritising aesthetics. Therefore, step dimensions are often suboptimal for users' safety due to larger rises and shorter goings (Templer, 1992). Consequently, even though the regulations on dimensions are more lenient for private homes, many homes have stairs with dimensions that do not meet the newer regulations. In a mail back survey issued in the early 1990s, over 40% of respondents reported home stair dimensions that had a smaller going than the regulations at that time (Roys, 2001).

The lack of compliance of home stairs is cited to be a confounding factor in increased fall rates compared to those on public stairs (Johnson & Pauls, 2010). The USA and Canada have adopted the maximum 178 mm rise (7 inch) by minimum of 279 mm going (11 inch) (Nemire, Johnson, & Vidal, 2016; NFPA 101, 2000) to try and eliminate more problematic stairs in future homes, however this has resulted in the increased use of prefabricated stairs which if not installed correctly can result in top or bottom step defects (Johnson & Pauls, 2010). Unfortunately, many existing stairs do not comply to legislation and new legislation does not apply retrospectively to existing properties and therefore only influences the construction of new stair structures and some renovations (Shaw, 2015).

The Building Research Establishment (BRE) in the UK has evidenced that individuals perceived stairs with larger rise heights and smaller goings as less preferable (Wright &

Roys, 2005). This was also reflected in measurements of foot overhang, which was greater on stairs with narrow goings and further increased with larger rises. Experimental literature has also identified that greater rise heights and narrow goings increase the kinetic demands of stair negotiation (Spanjaard, Reeves, van Dieën, Baltzopoulos, & Maganaris, 2008b) and thus have been linked to more reports of falls (Wright & Roys, 2008) particularly for older adults (Heinrich, Rapp, Rissmann, Becker, & König, 2010; Jacobs, 2016).

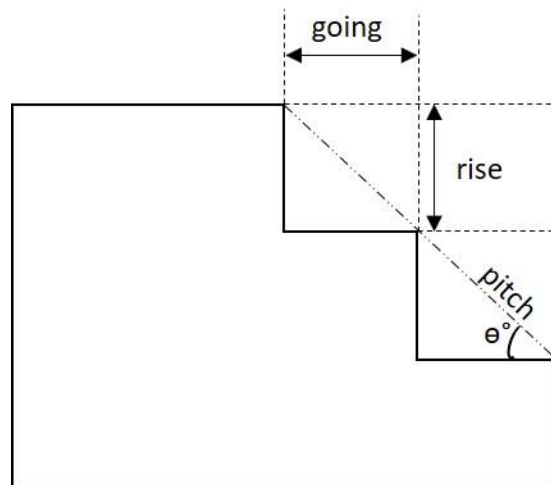

Figure 1.3. stair dimension terminology.

1.5.1 Rise dimensions.

Too small a rise and people could trip in ascent or slip in descent because they do not see there is another step as they walk (Templer et al., 1978), whereas, a high a rise, increases the demands on the body's muscular systems and CoM control (Templer, 1992). For example, when speed was controlled, during ascent of larger risers, knee and ankle moments were increased, fascicle shortening velocities increased, the ankle went through a greater range of motion with more dorsiflexion during stance and more plantarflexion during swing, consequently, the ankle musculature had to generate more power during the pull-up phase. The trailing limb also supported more weight until just before toe-off (Spanjaard et al., 2008b). Medio-lateral stability decreased with increased step height (Buckley, Heasley, Scally, & Elliott, 2005), compromising CoM control. Consequently,

people may struggle to pull themselves up during ascent, may not lift their leg high enough to clear the step-edge which could cause more tripping events (Templer, 1992; Templer et al., 1978).

In descent, a large rise causes difficulty during controlled lowering and may result in loss of balance as people fail to maintain control of their CoM, or may result in poor foot contact, consequently the large forces created during weight acceptance may not be effectively dissipated (Foster, Maganaris, Reeves, & Buckley, 2019). Older adults who have reduced muscle strength, must work closer to their maximum capacities during stair negotiation (Foster et al., 2019; Pijnappels, Reeves, Maganaris, & van Dieën, 2008; Reeves et al., 2009). Older adults tend to use the smaller muscles of the ankle less, compared to younger adults, however by negotiating larger rises, older adults are forced to use more of their maximal strength reserve. Older adults had shorter double support phases, greater hip extensor moments, ankle plantar flexor moments and ankle power absorption during the weight acceptance phase (King et al., 2018) when they negotiated steeper stairs compared to shallower stairs. During weight acceptance, there were increases in: the hip extensor moments in both limbs, ankle power generation in the lead limb and power absorption in the trailing limb (King et al., 2018).

1.5.2 Going dimensions.

When going dimensions are larger there is tendency for less accidents to be reported (Wright & Roys, 2008) as there is more space for the foot, increasing foot contact with the step and therefore reducing the amount of overhang. Longer goings also permit a larger base of support (BoS) which helps to improve control of the CoM (Novak, Komisar, Maki, & Fernie, 2016). Based on experimental data, it was suggested that stairs should be built with a maximum rise of 200 mm and a minimum going of 250 mm which would enable the majority of the population to fit 90% of their foot on the step and would create an average 10% of over-hang on a habitual basis, which could reduce the amount of slips and trips substantially (Wright & Roys, 2005). In more recent research, on stairs with going dimensions of 325 mm, there was greater difference in foot clearances and no other

perceived negative effects on stepping performance (Di Giulio, Reeves, et al., 2020). However, when goings are too long, normal gait is disrupted causing either an over-stretched gait or forcing a double step to occur on the same stepping surface, this could cause a trip or force inappropriate foot placement which may result in a slip (Templer, 1992).

Importantly, shorter goings limit the space available for foot placement, this will likely increase the chance of a fall by causing an under-step in ascent, or overstep or slip over the step-edge in descent (BSI, 2010; Di Giulio, Reeves, et al., 2020; Roys, 2001; Wright & Roys, 2005). Smaller goings may also cause a rotated crab-like gait (Templer, 1992; Templer et al., 1978) which permits more of the mid foot to be placed on the step surface, increasing proprioceptive feedback but which can load the smaller and weaker frontal plane muscles for the knee and the ankle. Smaller goings also result in smaller foot clearances which could increase the chances of experiencing a trip (Di Giulio, Reeves, et al., 2020).

1.5.3 Inconsistent dimensions.

It is stipulated within building regulations that stairs should be built with uniform step dimensions (HM Government, 2013). Yet, in section 5.4 of the British Standards it is acknowledged that, “it is unusual for the rise and going on any stair to be consistent throughout the whole flight; and variations from 4 mm to 6 mm are common” (BSI, 2010). These variations may be important in causing falls on stairs as variations of 6 mm are known to disrupt gait (Templer, 1992). In the USA, the regulations state that a variation between the largest and the smallest steps should not be more than 9.5 mm across the whole staircase and therefore adjacent steps should not be different from the design by more than 4.7 mm. The UK regulations are a little harder to interpret, as it is stated that, stairs should be uniform to within the following tolerances: a) for private stairs a variation of $\pm 1\%$ of the rise and going from the design is permitted, b) for public stairs a variation of $\pm 1.5\%$ of the going and $\pm 1\%$ of the rise from the design is permitted. On a typical staircase with a going of 250 mm, these regulations mean that the maximum legal variation

between two successive steps is 5 mm in the home, but for public stairs that increases to 7.5 mm.

Accident investigations of serious falls on stairs have found large inconsistencies in step dimensions were present in the majority of cases investigated (H. Cohen, 2000; J. Cohen, LaRue, & Cohen, 2009). Out of 80 serious fall cases investigated in the USA, 30% of the stairs had at least one step with a difference in going greater than the permitted variability of 9.5 mm across the whole flight. Sixty percent of the stairs investigated had at least one riser with a difference larger than 9.5 mm (J. Cohen et al., 2009). Templer (Templer, 1992; Templer et al., 1978) has summarised from the previous accident work (Miller and Esmay, 1958) that on stairs where serious accidents had occurred over 40% of the stairs had variations in rise greater than 6.3 mm. The effects of inconsistent risers were apparently confirmed with video observations of Templer and colleagues (Templer et al., 1978), although it was not clear what exactly was or wasn't observed in those video assessments.

Templer (1992) also noted that in other observational studies, at the 1976 Montreal Olympics and at 1987 Molson Indy Race in Toronto, stairs that had an inconsistent higher rise caused a tripping incident during ascent at a ratio of 1:20 and 1:16, respectively. When the dimensions were made more consistent the observable trip rate reduced to 1:1000 for the Olympic stadium and there were no incidents observed for a few thousand users at the Indy race. These reports did not conform to the highest standards of experimental design and data verification, yet the striking reduction in incident rates highlights the large effect inconsistent stair dimensions have on falls rates (Johnson & Pauls, 2010; Nemire et al., 2016; Templer, 1992).

1.5.4 Current understanding of fall mechanisms on inconsistent stairs.

To the author's and colleagues' knowledge there is no experimental evidence that documents the mechanisms by which the inconsistencies lead to falls. Current understanding of falls on inconsistent stairs is based on the assumption that the user does not detect the inconsistency or adapt their stepping behaviour to accommodate for it.

This untested assumption is then combined with observational data and models of “normal” human movement and the associated variability to predict fall mechanisms.

It is suspected that inconsistent dimensions are extremely difficult to detect and it is thought that visual information collected prior to and during stair negotiation helps create a movement plan for the stairs (Hale and Glendon, 1987 as cited by Templer, 1992). When, this plan is matched with proprioceptive feedback of the first few steps, stair users define their movement pattern after three steps and continue this for the rest of the stairs (Miyasike-Dasilva et al., 2011; Templer, 1992). As humans there are certain expectations about stairs; as stairs are engineered, they are assumed to be safe, so unless a hazard is obvious it is unlikely to illicit a change in stepping behaviour until the inconsistency has already caused a perturbation to balance, which for some could be too late.

When relying on the above assumption, falls on inconsistent steps are hypothesised to occur because users contact the step in a place and time that is unexpected (Roys, 2013). Inconsistent going dimensions, are predicted to reduce the amount of the foot that is securely placed over the step at initial foot contact, increasing the overhang and risk of slip during the loading phase. It is suspected that this risk is magnified on stairs with shorter goings and larger risers (Roys, 2013). For example, when compared to stairs with consistent goings of 300 mm where the level of risk could be minimal as most people would fit most of their foot onto the step. The risk of overstepping increases on stairs with smaller goings such as 250 mm (Wright & Roys, 2005) and is predicted to increase further with a larger magnitude of variability (Roys, 2013). These predictions were based on normal walking patterns and variability in foot placement for about 60 individuals on an adjustable stair rig with consistent dimensions (Roys & Wright, 2005; Wright & Roys, 2005) and does not reflect the presence of an inconsistency. Inconsistent large rises have been observed to cause tripping events during ascent (Templer, 1992) in less than optimal study conditions.

All these mechanisms remain theoretical, it is not yet known how an inconsistent rise dimension might affect descent nor how an inconsistent going dimension might affect ascent.

1.6 Rationale and Aims of Thesis

There seems to be a strong link between inconsistent dimensions and serious injuries and that there are many stairs that do not comply to current legislation on variable stepping dimensions. Considering our present understanding of falls on stairs with inconsistent dimensions relies mostly on observations, post fall investigation work and theoretical predictions based on normal stepping behaviour, the literature has neglected to assess the biomechanical impact of inconsistent dimensions on stepping mechanics and overall balance control, it is therefore important to empirically test what happens when individuals negotiate inconsistencies and why that could put them at an increased risk of experiencing a fall. Irrespective of the direction individuals are travelling, it is important to understand how stepping mechanics and balance control is influenced by an inconsistency in the mid-flight region where the stepping rhythm is already established and therefore somewhat controlled. This knowledge can be later applied to the more challenging task of transitioning onto or from the stairs to the level which may be subject to different stepping techniques and more sensitive to visual information.

Older adults are the most at risk of serious stair falls but there is still a high prevalence for younger adults to experience serious falls as well, thus it is important to understand the underlying mechanisms and exactly how inconsistent dimensions could impact the stepping behaviour, balance control and safety of these individuals. Only when this is understood would it be possible to develop and implement preventative fall initiatives, for example developing environmental cues to highlight the inconsistent hazard, or advising at risk groups to take more precautions on stairs such as scanning the steps more carefully and or holding handrails. This biomechanical understanding may also help inform legislative bodies, so they can adjust the building practices, regulations and put in place new measures to ensure that all parties adhere to uniformity expectations in

dimensions. At present, the building regulations still permit and even expect inconsistencies on stairs and as such many stair falls will continue to happen at a high rate. More needs to be done to understand how inconsistencies impact on fall risk before safer building policies can be introduced and fall prevention initiatives can be implemented.

Therefore, this thesis aims to establish the mechanisms by which inconsistent step dimensions increase the risk of the user and can lead to such high fall rates. This will be achieved in three experimental chapters, following the general methodology (Chapter 2):

- Chapter 3 - Inconsistent Rise, which aims to investigate how the biomechanical stepping parameters are affected with the presence of rise inconsistencies on stair ascent and descent.
- Chapter 4 - Inconsistent Going, which also aims to determine how the biomechanical stepping parameters are affected with the presence of inconsistent goings on stair ascent and descent.
- Chapter 5 - Balance and CoM Control, which will document the changes to CoM control during descent when negotiating over the inconsistent rise and inconsistent going dimensions.

A more technical methodology will be provided within each experimental chapter for clarification. The outcomes from the experimental chapters will then be synthesised along with existing literature in Chapter 6 to address limitations of the present study and present future avenues for biomechanical and industry research that could help to reduce the amount and severity of falls in the population.

Chapter 2: General Methodology

Acknowledgements: The foot model and Matlab scripts used to determine foot clearance and percentage foot contact parameters were developed by Denis Holzer.

2.1 Introduction

This general methods chapter provides an overview of the participants, experimental protocol, data collection, foot model, whole-body model and data analysis pertinent to Chapters 3, 4 and 5 of this thesis. All data was collected in the same experimental session and with the same lab setup described in this chapter. Specifics relevant to an individual chapter are outlined within that chapter's methodology. All the data presented in this thesis was collected on the custom built, instrumented staircase (Figure 2.1) in the Movement Function Research Laboratory of Liverpool John Moores University.

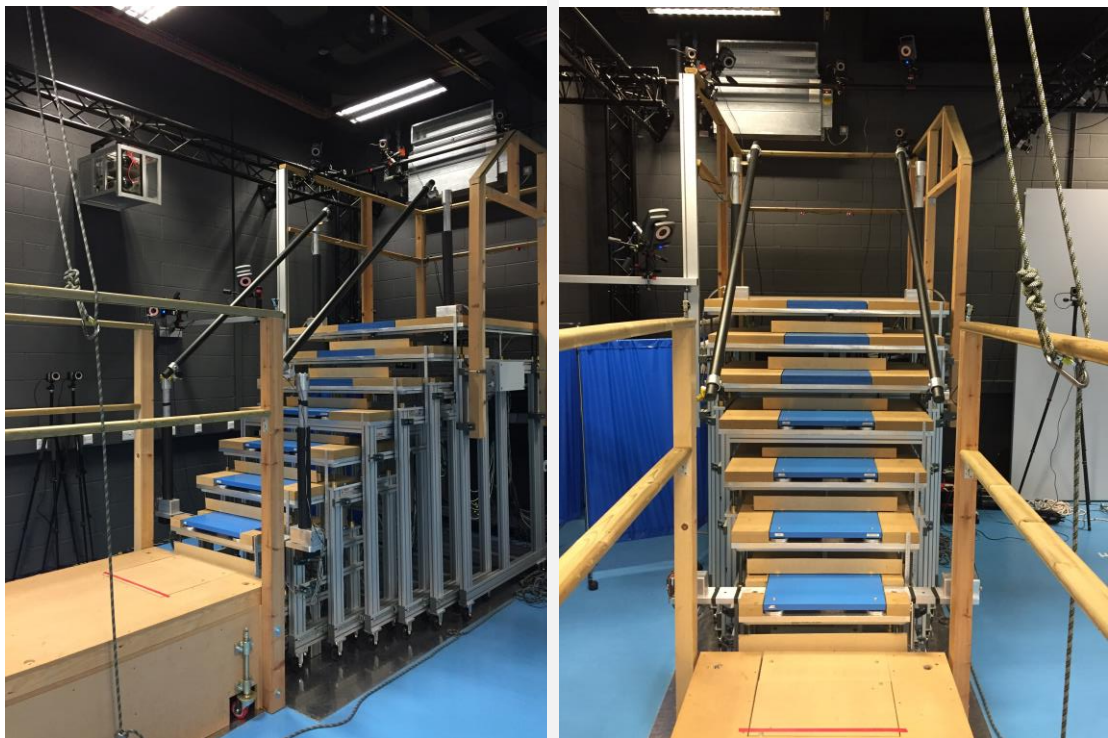

Figure 2.1. The seven-step stairs, integrated with four Kistler force plates in the bottom four steps, and three dummy wooden blocks secured into the top three steps. The safety rope seen in the figure was connected to an overhead safety rail. The connector was attached to the participant's safety harness for all trials. The other end of the rope was controlled by a trained member of the team.

2.2 Participants

In total twenty-six younger adults (24 ± 3 y, 1.74 ± 0.09 m, 71.41 ± 11.04 kg) and thirty-two older adults (70 ± 4 y, 1.68 ± 0.08 m, 67.90 ± 14.10 kg) took part in this study. The study was approved by the NHS research ethics committee (IRAS ID: 216671) and University ethics and was conducted in accordance with the Declaration of Helsinki. Younger adults were recruited through the University email system and word of mouth. Older adults were recruited through the University email system, from community group meetings, community activity classes and word of mouth. All participants provided written informed consent.

2.2.1 Inclusion criteria.

Participants were included in the study if they met the following criteria at the point of consent: 1) were within the age criteria at the time of testing for either the younger adult group (18-30 years of age) or the older adult group (65+ years of age), 2) were free from lower-limb injury in the six months prior to testing, 3) lived independently within the community and 4) self-reported that they used stairs regularly at home or in the environment.

2.2.2 Exclusion criteria.

In addition to the above inclusion criteria, participants were later excluded from the study if they were not comfortable or deemed safe to negotiate the stairs in a step-over-step manner without using handrails during the familiarisation session (see below) or during data collection.

2.3 Protocol

All participants were familiarised to the staircase prior to data collection. For the older adults, the familiarisation occurred on a separate day at least seven days before the data collection session. For young adults, the familiarisation and data collection occurred on the same day, separated by a short break. During familiarisation, participants were

fitted into the 5-point safety harness and were connected to an over-head safety rail via rope, which was controlled by a trained member of the research team who was also secured via rope to the floor. The participants navigated the stairs in a step-over-step manner and were initially permitted to use the handrails if they wished. They were allowed to ascend and descend as many times as they wished until they were comfortable (usually two of each). Those who chose to use the handrails were asked if they were comfortable not to use them and were given more practice trials.

During the measurements, participants wore tight fitting clothes and their own comfortable shoes with a closed toe and no raised heel. Participants were fitted into the harness again and were attached to the overhead safety system, they were then re-familiarised with the seven-step stairs with consistent dimensions following a similar procedure to that of the familiarisation session.

Data collection began on the consistent stair in all cases. The stair dimensions were similar to those in private homes and complied to current UK building regulations (BSI, 2010) (rise 200 mm and going 250 mm and pitch 38.7°, see Figure 2.2a). Participants were then asked to leave the room and rest (~10-15 minutes) during which time the stairs were re-configured with either an inconsistent higher rise (Figure 2.2 Part A.) or an inconsistent shorter going (Figure 2.2 Part B). The order of inconsistent rise or inconsistent going conditions were randomly selected for each participant. After completing five trials of the first assigned inconsistent configuration, participants left the room again and returned to negotiate the remaining stair configuration.

Between each configuration, participants were told that the staircase may or may not change while they were out of the room. There was no indication as to the original dimensions nor how the dimensions would change, either across the stairs or inconsistently. On completion of each inconsistent condition, older participants were asked to give their verbal feedback by answering an unstructured question. They were asked if they had noticed anything being different and if it was different, where they thought the difference/s were. The participants answers were briefly noted, but nothing

was disclosed to the individual until the completion of the study. This allowed the researcher to check if individuals were indeed perceiving the changes that had been made. Participants were asked not to disclose the stair dimensions or changes to others who may be completing the study.

- For the **inconsistently higher rise condition**, only the third step from the bottom up (Step3) of the stairs was raised 10 mm. To maintain the overall pitch at 38.7°, the position of Step4 was not changed, which consequently decreased the rise height from Step3 to Step4 by 10 mm (Figure 2.2 Part A).
- For the **inconsistently shorter going condition**, only the third step from the bottom up (Step3) of the stairs was moved inwards 10 mm. To maintain the overall pitch at 38.7°, the position of Step2 was not changed, as a result the going/ tread on Step2 became 10 mm longer (Figure 2.2 Part B).

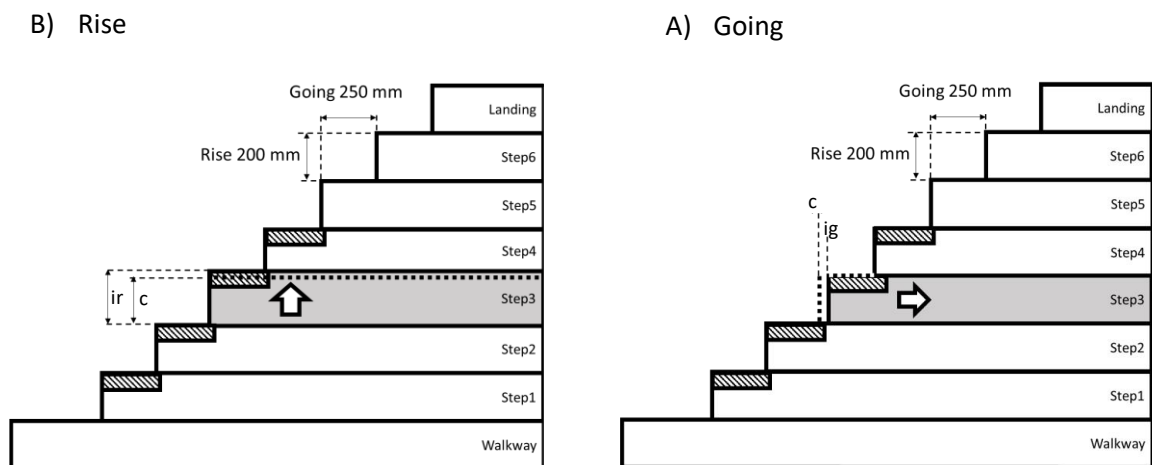

Figure 2.2. Seven-step stairs, with four force plates located in Step1-4. For the consistent condition, c) all steps had a rise height of 200 mm, a going of 250 mm. A) for the inconsistent rise condition, ir) only Step3 was moved 10 mm upwards, increasing rise to Step3 to 210 mm thus reducing rise to Step4 to 190 mm. B) for the inconsistent going condition, ig) only Step3 was moved 10 mm inwards, increasing Step2 going to 260 mm thus reducing Step3 going to 240 mm, all other steps and pitch remained unaltered.

The 10 mm dimension inconsistencies are not permitted in the UK nor in the USA building regulations. However inconsistencies greater than this magnitude have been observed in both dimensions within home stairs (Roys, 2001, 2013) and within the

environment (J. Cohen et al., 2009). Since, the purpose of this study was to assess the mechanisms by which falls occur on inconsistent staircases in real-world situations and existing staircases, it was decided that 10 mm inconsistency provided greatest external validity.

Participants completed five ascent and five descent trials of each condition. All participants started from a self-selected distance away from the stairs that permitted one level ground step to be taken on the walkway before commencing stair ascent or one level ground step to be taken on the landing before commencing descent, this starting position was marked with a line of tape. This condition was implemented to minimize variations in approach to the stairs. On the researcher's signal, participants first stepped with their left limb on the walkway or landing, this ensured that the same limb was used for the same steps across the three conditions. The right foot was always the first foot to step onto the stairs, participants continued in a step-over-step manner without use of the handrails towards the landing or walkway, and they took two level ground steps before stopping. Participants rested for as long as they wanted between trials. This protocol was repeated for the two inconsistent conditions.

To minimize any learning effects for this study, only the first ascent and descent trial was analysed for the inconsistent conditions, however participants always ascended before they descended the stairs.

2.4 Instrumentation

Kinematic 3D motion data was captured using 24 infra-red Vicon cameras covering the whole stairs, landing and walkway (120 Hz, Vicon, Oxford Metrics, UK). The camera positions were determined from extensive pilot work described in Appendix A and included the integration of TX100, TX160 and Bonita cameras to ensure whole body CoM could be tracked throughout the whole movement. Kinetic data were synchronously recorded from four force platforms (1080Hz, 9260AA, Kistler AG, CH) embedded in the lower four steps of the stairs (Step1-4, Figure 2.1). These positions were decided on so that continuous stair climbing was achieved and so that the step before, the inconsistent step

and the next step could be used in the analysis for ascent and descent. Having a continuous stair descent stepping was prioritised over ascent as disturbances to balance in descent could result in more frequent and more serious injuries (Christina & Cavanagh, 2002). Due to the way the stairs were manufactured it was not possible to change the riser height of Step4 without adjusting the whole staircase, Step3 was considered the next most appropriate step. It was crucial to identify the correct location of the step-edges and force plates relative to the calibrated origin (which was set to Step1) in all conditions, Appendix B provides more detail on this process. The raw data were integrated through Nexus software (Nexus Vicon 2.5, Oxford Metrics, UK).

To calculate foot clearance and percentage foot contact length a custom foot model was developed to incorporate methods used by previous researchers (Muhaidat, Kerr, Rafferty, Skelton, & Evans, 2011; Telonio, Blanchet, Maganaris, Baltzopoulos, & McFadyen, 2013). The Telonio and colleagues' model (2013) used a series of digitised points on the sole of the shoe to provide a 3D mesh representing the sole, from this mesh the minimal clearances could be determined. Muhaidat et al. (2011) used anatomical based markers to indicate foot placement on steps and clearances from the heel marker to the step-edges. The custom foot model was used in chapters 3 and 4., To calculate whole-body CoM motion a full body six degrees of freedom model was used with additional markers to improve tracking across the whole capture volume (in Chapter 5). All data was obtained from the same trials and all markers were 14 mm in dimension.

2.5 Custom Foot Model/Markers

Foot markers were placed on the lateral and medial malleolus and on the shoes on the first and fifth meta-phalange joints, the calcaneus, the lateral and medial calcaneus, the shoe upper (near laces) or top of the foot (shoe style depending) and a cluster of three markers were placed over the toes (Figure 2.3). The anterior posterior axis of foot was determined with a marker placed on the hallux (only present in the static trial). The lateral calcaneus, first and fifth metatarsal markers were used to define a 2D shoe sole surface model which was created by tracing the outline of the shoes onto paper with respect to

the centre of the lateral calcaneus, first and fifth meta-phalange markers. This technique simplified the Telonio model (2013) to produce a 2D outline of the shoe sole that could be used to obtain more representative foot clearances and foot placements than those reported in the Muhaidat model (2011). The advantages of the custom model were that drawing round the shoes was faster than individually having to go around each sole with a pointer, individuals were seated and less likely to move their feet orientation compared to if they had to balance on one foot while the sole was digitised. Additionally, the outlines were retained and could be re-digitised multiple times to check accuracy and consistency of outcome parameters, a process that could not be done for the Telonio model without retesting the individual.



Figure 2.3. Foot model markers used for foot clearance and percentage foot contact length variables. Including the lateral calcaneus marker placed as close to join of the shoe sole and shoe upper as possible, 1st metatarsal head, 5th metatarsal head, the toe cluster was used to estimate toe spring clearance. The shoe outline and marker centres were drawn onto a piece of A4 paper.

To calculate foot clearance and percentage foot contact length variables, filtered kinematic and kinetic data were imported into Matlab (R2017b, The Mathworks, Natick, USA) along with step-edge locations (defined by custom-made clusters of known dimensions), the participant static calibration and the digitized shoe sole outlines (ImageJ: National Institutes of Health, Bethesda, USA). This Matlab script was created by Denis Holzer as part of his Master thesis titled “Effect of variable staircase dimensions on postural stability during stair negotiation in younger adults”.

2.6 Whole-Body Model

An adapted plug-in gait model was used to define a whole body model with 6 degrees of freedom, a total of 76 Markers were placed on the skin and on the tight fitting clothing of the participants to define 15 segments including: head (on a head band), thorax, upper arms, lower arms, hands, pelvis, thighs, shanks and feet. Aside from the foot markers already mentioned other changes to the plug in gait model are as follows: 1) the head had two additional markers one above each ear (determined the medial lateral axis of the head and improved segment orientation on walkway and landing); 2) a marker was placed on each medial epicondyles of the humerus (improved upper arm orientation and improved tracking of forearm rotation, important for handrail usage); 3) the finger markers were moved to the third finger (better represented the axis of the hand), 4) a sacrum marker was used in addition to the four pelvis markers (improved pelvis tracking, from marker loss caused by harness during ascent); CoM of the segments were defined *in Visual 3D (version 6.01.043 Visual3D, C-Motion, Germantown, USA)* according to Dempster's regression equations (Dempster, 1955) and were individualised to a participants height and mass as described by Hanavan (Hanavan, 1964).

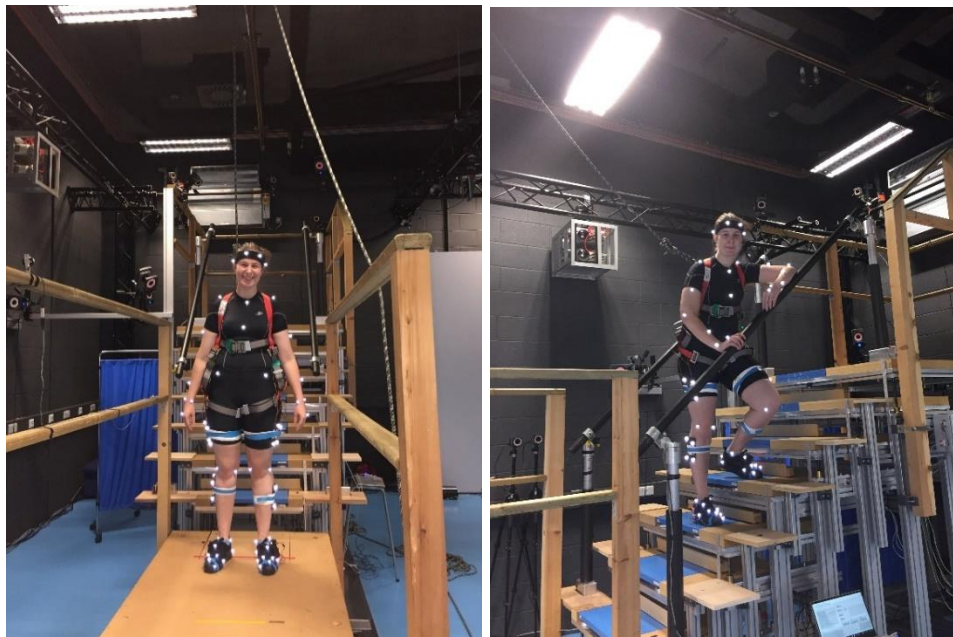

Figure 2.4. Adapted plug in gait model, 6 degrees of freedom, defining 15 segments. 76 markers were uses in total. Additional markers were used on the head, elbows, pelvis and feet to improve tracking across the whole stair, walkway and landing areas.

2.7 Data Analysis

Marker data was manually labelled and then gap filled in Nexus (Nexus Vicon 2.5, Oxford Metrics, UK) using the built in “Rigid Body Fill” and “Pattern Fill” Tools, in each case markers on the same segment were chosen to represent the correct trajectory of the missing marker.

Data from at least three trials were averaged (five where possible, average number of trials = 4.7 ± 0.6) for the consistent dimension condition and the first trial was used for the inconsistent rise condition and the inconsistent going condition, trials with incomplete force data or long periods of occluded markers were not included in the analysis. Kinetic and kinematic data were filtered using a low-pass fourth order Butterworth filter with a cut-off frequency of 6 Hz in Visual 3D (version 6.01.043 Visual3D, C-Motion, Germantown, USA). Filtered data were then integrated in to Matlab (version 17a Matlab, The Mathworks Inc, USA) or into individual .CMO files for Visual 3D (version 6.01.043 Visual3D, C-Motion, Germantown, USA) for the calculation of outcome measures.

2.8 Outcome Measures

The purpose of this thesis was to establish the mechanism by which inconsistent step dimensions increase the risk of the falls for the user. Previously it was thought that the main causes of falls on stairs are trips, slips (Templer, 1992; Templer et al., 1978) and loss of dynamic control of the CoM (Bosse et al., 2012; Heijnen & Rietdyk, 2016; Templer, 1992; Templer et al., 1978). Therefore, the outcome measures chosen to reflect these fall mechanisms were: Foot Clearance, Percentage Foot Contact Length, Foot CoM Position as these are utilised in both Chapter 3 and 4 they are outlined within this general methodology. The outcome measures relating to CoM and balance control are defined within Chapter 5 and include parameters that are associated with stability: temporal characteristics, ground reaction forces (GRF), loading rates, frictional properties and derivatives of whole-body CoM positions.

Foot clearance (mm) was chosen as the outcome measure to quantify the risk of toe or heel catch, as a reduction in clearance is associated with an increased trip risk

(Hamel, Okita, Higginson, et al., 2005; Roys, 2001). In ascent foot clearance was defined as the minimal vertical distance from the step-edge to the most anterior point of the projected shoe sole outline (including toe-spring correction). Foot clearance was calculated as the minimal vertical distance between the outline and the step-edge, usually at the instant the toe passed the horizontal position of the step-edge (Figure 2.5 Part A). Toe-spring is the vertical gap that is created under the toes of most modern shoes and the floor, this was not reflected in the 2D surface model of the shoe and instead was applied post data collection. The mean toe-spring height for a range of shoes tested was 53% of the distance between the top of the shoe (determined experimentally from the base of the toe clusters visible in Figure 2.3) and the floor. Each participant's toe-spring correction value was only applied to the most forward point of the shoe sole across all conditions. In descent (Figure 2.5 Part B), foot clearance was measured as the minimal horizontal distance between the step-edge and the posterior point of the projected shoe sole, usually at the instant the heel passed the vertical height of the step-edge. Therefore, toe-spring was not corrected for.

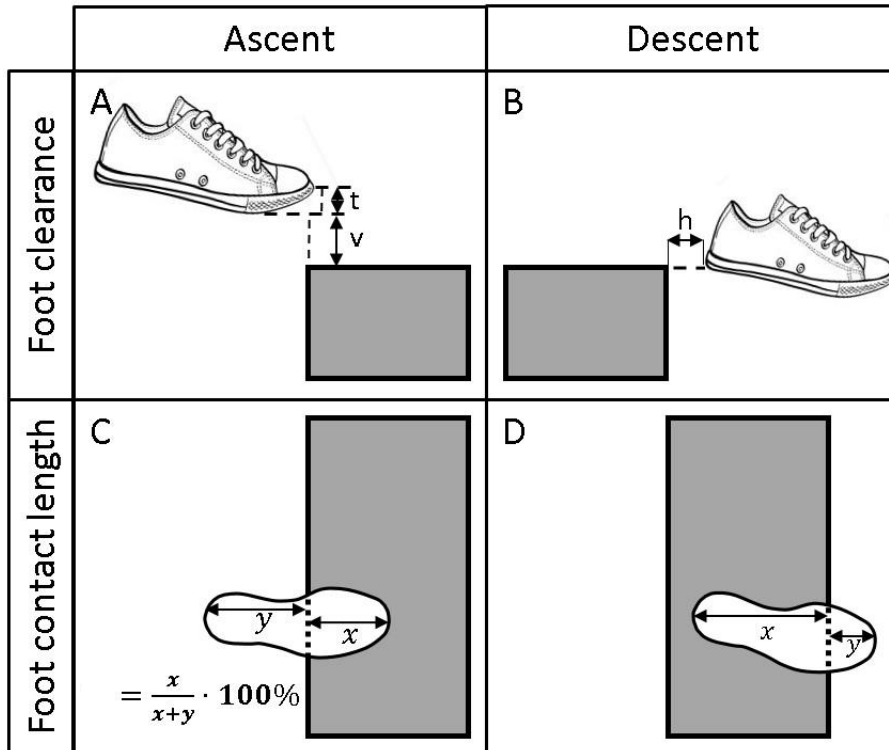

Figure 2.5. A) vertical (v) foot clearance in ascent, with toe-spring correction (t) added B) horizontal (h) foot clearance in descent, C) foot contact length percentage in ascent and D) descent; linear horizontal distance of foot over the step (x). linear horizontal distance of foot not over the step (y), as foot may be in plantar flexion.

Percentage foot contact length (%) was chosen as the outcome measure to quantify the risk of over-stepping in descent and under-stepping in ascent, which both could increase the chances of a slip occurring (Christina and Cavanagh, 2002; Roys and Wright 2005). Percentage foot contact length defines the proportion of the projected shoe sole, over the step at initial contact (force threshold 50 N) and is defined by the equation: Percentage foot contact = $\frac{x}{x+y} \cdot 100\%$. So in ascent (Figure 2.5 Part C), the ratio of the anterior portion of the projected shoe sole (x) to the sum of the anterior portion (x) plus the posterior portion of the projected shoe sole (y). In descent (Figure 2.5 Part D), the ratio of the posterior portion of the shoe over the step was of interest so the figure is reversed.

Foot CoM position (mm) or trajectory, was used to quantify how the whole foot moved during swing, prior to contact with the inconsistent steps. It was also used to track

stepping pattern and explain any observed effects on clearance and contact length.

Trajectories between toe-off and contact on the next step were obtained from Visual 3D and made relative to 100% of swing. The trajectories were calculated based on absolute position of the whole foot CoM within the lab co-ordinate system, the origin of the lab was defined as the right corner of Step1 force plate, which was also in line with the step-edge. This parameter gives richer frame by frame information rather than just minimal foot clearance which is instantaneous in nature and may be comparable to studies using inertial sensors to monitor stepping behaviour (Laudanski, Brouwer, & Li, 2013).

2.9 Statistical Analysis

To compare differences in outcome measures at key events and to assess fall risk, between the consistent condition and the inconsistent conditions, 2-way mixed method design, Repeated Measures Analysis of Variance (ANOVA) tests were conducted for ascent and descent. Alpha level was set at 0.05. An exploratory approach was used after the primary outcome measures were determined. Secondary outcome measures, specific to each chapter, were analysed to provide mechanistic understanding of participant behaviour when they negotiated the inconsistencies and underpin the primary outcome measures. These included foot and CoM trajectories, which were analysed with one dimensional statistical parametric mapping (SPM, available from www.spm1d.org) (Pataky, 2012). The size of groups and conditions were balanced to comply with the required assumptions. The specifics of each statistical analysis are described within each chapter.

Chapter 3:

Biomechanics of Stepping on Stairs with an Inconsistent Rise

The data presented in this chapter has been accepted for publication in Applied Ergonomics (Francksen et al., 2020) a copy of this publication is available online via: <https://doi.org/10.1016/j.apergo.2020.103131>. Additionally, elements of this chapter have been presented at conferences including:

Francksen N, Ackermans T, Holzer D, Maganaris C, Hollands M, Roys M, O'Brien T. (2018). Inconsistencies in staircase dimensions impact upon stair climbing safety. Paper presented at 42nd Annual Meeting of the American Society of Biomechanics, Rochester, Minnesota, USA, 2018. (Competing in the ASB Student Award).

Francksen N, Ackermans T, Holzer D, Maganaris C, Hollands M, Roys M, O'Brien T. (2018) Stair ascent: the influence of inconsistent rise step dimensions on younger and older adults' safety. Poster presented at the 8th World Congress of Biomechanics, Dublin, Ireland, 2018.

Holzer D, Ackermans T, **Francksen N**, Foster R, Robinson M, Baltzopoulos V, Karamanidis K, Hollands M, O'Brien T, Maganaris C (2017). Step rise inconsistency may go undetected when ascending stairs: implications for stair safety. Poster presented at the International Society for Posture and Gait Research Conference, Miami, Florida, USA, 2017.

Acknowledgements: The younger adult ascent data was separately analysed and submitted as part of Denis Holzer's Master thesis as a visiting ERASMUS student. The repeat rise trials data were processed and analysed with assistance from Sophia Ebner a visiting intern to the lab.

3.1 Introduction

In an investigation of 80 stair falls, it was found that 60% of the stairs involved had an inconsistency in the rise, which was larger than the maximum USA. limit of 9.5 mm (J. Cohen et al., 2009). An inconsistently greater rise has been observed to increase the occurrence of toe-catches and trips in ascent (Johnson & Pauls, 2010; Templer, 1992). However, mechanisms of falls due to an inconsistent rise in descent have not been studied, although it is proposed that they may reduce foot contact length, increasing the risk of a slip (Roys & Wright, 2005). Given that more severe injuries occur during descent than ascent (J. Cohen et al., 2009; Templer, 1992) this gap in our knowledge prevents adequate intervention design or policy making to reduce rates of the most important falls.

It is suggested that visual information is used to help create a cognitive plan of the stairs, which prepares the motor response and appropriate stair biomechanics (Hale and Glendon, 1987; as cited by Templer, 1992). With the inclusion of proprioceptive feedback from first few steps, a user is thought to have established their stepping pattern for the stairs after only three steps (Roys & Wright, 2005). Therefore, if a subsequent step inconsistency is not detected or not interpreted as a danger, then there becomes a discrepancy between perception and the real stairs consequently increasing the risk of a miss-step (Roys, 2001; Roys & Wright, 2005; Templer, 1992).

Older adults are generally at a greater risk of stair falls than younger adults (Blazewick et al., 2018; BSI, 2010), but it is not known whether they respond to stair inconsistencies in a different way. The ageing-associated deteriorations in vision, as well as musculoskeletal function and motor control (Startzell et al., 2000), may make older adults less able to detect inconsistencies and less able to respond to a loss of balance putting them at a greater risk of a fall.

Therefore, the aim of this experimental chapter was to identify the mechanisms by which steps with inconsistent rise heights increases the risk of a toe- or heel-catch (trip) or overstep (possible slip) and to determine whether these risks for a fall are different between younger and older adults.

3.2 Hypothesis 1

In stair ascent, for both younger and older adults, an inconsistent higher rise will cause a decreased foot clearance from the inconsistent step-edge (higher rise) and will reduce the amount of foot contact length on the inconsistent step.

3.3 Hypothesis 2

In stair descent, for both younger and older adults, an inconsistent higher rise step will cause a reduced foot contact length on the inconsistent step (after smaller rise) and will negatively affect subsequent foot clearances.

3.4 Methods

The general methods for the collection and analysis of the data presented in this chapter have been described in detail in Chapter 2. Since the aims of this experimental chapter are to quantify the effects of an inconsistent rise on stepping mechanics, only comparisons between the consistent condition (Figure 3.1 a) and the inconsistent rise condition are considered. In summary, for completeness, the inconsistently higher rise was created by raising the third step from the bottom up (Step3) of the stairs by 10 mm. To maintain the overall pitch at 38.7°, the position of Step4 was not changed, which consequently decreased the rise height from Step3 to Step4 by 10 mm (Figure 3.1 b).

Data from at least three trials were averaged (five where possible, average number of trials = 4.7 ± 0.6) for the consistent dimension condition and the first trial was used for the inconsistent higher rise condition, trials with incomplete force data or long periods of occluded markers were excluded from analysis. Participants always ascended before they descended the stairs. The main outcome measures of interest for this chapter were foot clearance and percentage foot contact length, which are defined in section 2.8 of Chapter 2. Participants were asked on completion of the study if they knew if or how the staircase was altered.

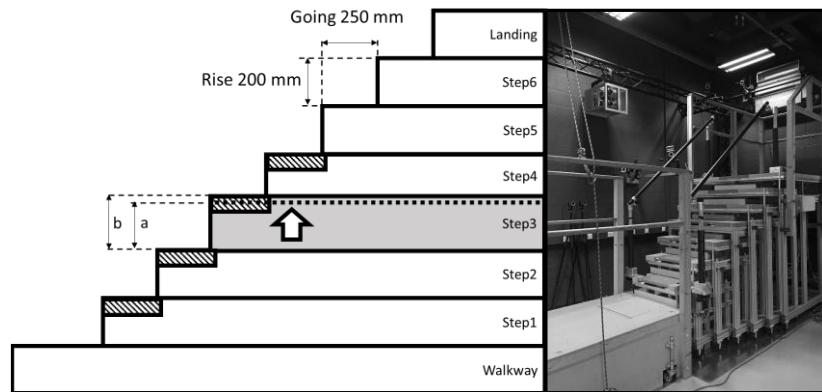

Figure 3.1. Seven-step stairs, with four force plates located in Step1-4. For the consistent condition a) all steps had a rise height of 200 mm, a going of 250 mm. For the inconsistent rise condition b) only Step3 was moved 10 mm upwards, increasing rise to Step3 to 210 mm thus reducing rise to Step4 to 190 mm, all other steps and pitch remained unaltered.

3.4.1 Statistical analysis.

Primary analyses of the two outcome measures were performed using a 2-way mixed method design, Repeated Measures Analysis of Variance (ANOVA) for ascent and descent. Foot clearance (Step1-Landing) and percentage foot contact length (Step1-Step4) were included in the same multivariate analysis. Comparisons were determined, within each condition (consistent versus inconsistent rise stairs) and between the two age groups (younger versus older adults) with an alpha level set at 0.05 at the univariate level, meaning that each step was treated independently of the other (some clearances/contacts decreased while others increased).

One-dimensional Statistical Parametric Mapping (SPM) was used to compare the kinematic trajectories of the foot Centre of Mass (CoM) on the approach to the inconsistent step. Foot CoM trajectories were obtained during swing between toe off and one frame before contact on the next step. For the consistent condition trajectories were collected until 10 mm vertically higher than 1 frame before contact, thus ensuring that both conditions finished at a similar vertical point in space. For ascent the vertical position data was plotted against 100% of horizontal progression. Due to the shape of the descent curve, it was not possible to normalise the horizontal progression in descent therefore vertical and horizontal position data was normalised to time. A SPM two by one-way

ANOVA requires a balanced design between groups and conditions, a random number generation algorithm was used to exclude the appropriate number of older adults for each analysis. To ensure the random selection produced similar results, this process was repeated at least 5 times. Each repeat analysis produced similar results, consequently we report results from the first analysis.

Additional 2-way Repeated Measures ANOVAs were used on foot CoM position data to determine change in absolute lab coordinate positions during stance irrespective of the stair configuration. This enabled the researchers to disregard the altered position of the step-edge in the two conditions.

3.5 Results

3.5.1 Stair ascent.

In the ascending trial of the inconsistent higher rise condition, one older adult tripped on the inconsistent higher edge of Step3; this person's ascent data were excluded from the analysis. It is important to note that this person made contact with the riser of Step3, the vertical foot clearance was not adequate to safely clear the inconsistently higher step-edge.

On the consistent stairs, on average older adults' foot clearances did not significantly differ over the steps (Steps2-6) (39 ± 15 mm) compared to the younger adults (37 ± 9 mm, $p = .624$). Older adults did have a significantly greater percentage foot contact length ($76.7 \pm 10.8\%$) compared to the younger adults (Steps 1-4) ($67.4 \pm 9.5\%$, $p = .001$, Appendix D). Also, the clearances over the transition step-edges of Step1 and the Landing step-edge were not significantly different between groups ($p = .231$ and $p = .602$, respectively).

In ascent of the consistent condition (mean \pm standard deviation), foot clearances over Step3 for the younger adults were 42 mm (± 11 mm) and 42 mm (± 18 mm) for the older adults. In the inconsistent rise condition, both groups significantly reduced their clearance by ≈ 9 mm over the inconsistently higher Step3 (younger adults: 34 ± 12 mm,

older adults: 32 ± 20 mm, $p < .001$). Foot clearance was also significantly reduced on the first step of the stairs for older adults by ≈ 6 mm (consistent: 60 ± 19 mm, inconsistent rise: 54 ± 20 mm) compared to younger adults ≈ 2 mm reduction (consistent: 55 ± 17 mm, inconsistent rise: 52 ± 15 mm, $p = .019$). However, there was no interaction between condition and age group. After the inconsistent higher step, foot clearances increased over the inconsistently shorter step Step4 ($p < .001$) and Step5 ($p = .040$) in both groups compared to the consistent condition. The only significant age*condition interaction for foot clearance was over Step4 ($p = .045$), where older adults had a larger increase of ≈ 17 mm in clearance (consistent: 38 ± 15 mm, inconsistent rise: 55 ± 18 mm) in the inconsistent rise condition compared to younger adults which only had a change of ≈ 10 mm (consistent: 37 ± 11 mm, Inconsistent rise: 47 ± 15 mm, Figure 3.2 Part A).

Percentage foot contact length on the inconsistent stairs was increased by $\approx 3.5\%$ on Step4 ($p < 0.001$) for the younger (consistent: $64.5 \pm 10.3\%$, inconsistent rise $68.7 \pm 9.9\%$) and older adults (consistent: $74.9 \pm 11.6\%$, inconsistent rise: $77.7 \pm 12.1\%$) compared to the consistent condition. All other foot contact lengths were not significantly different between the two conditions. There were no interactions between stair condition and age group for contact length (Figure 3.2 Part B, and Appendix D).

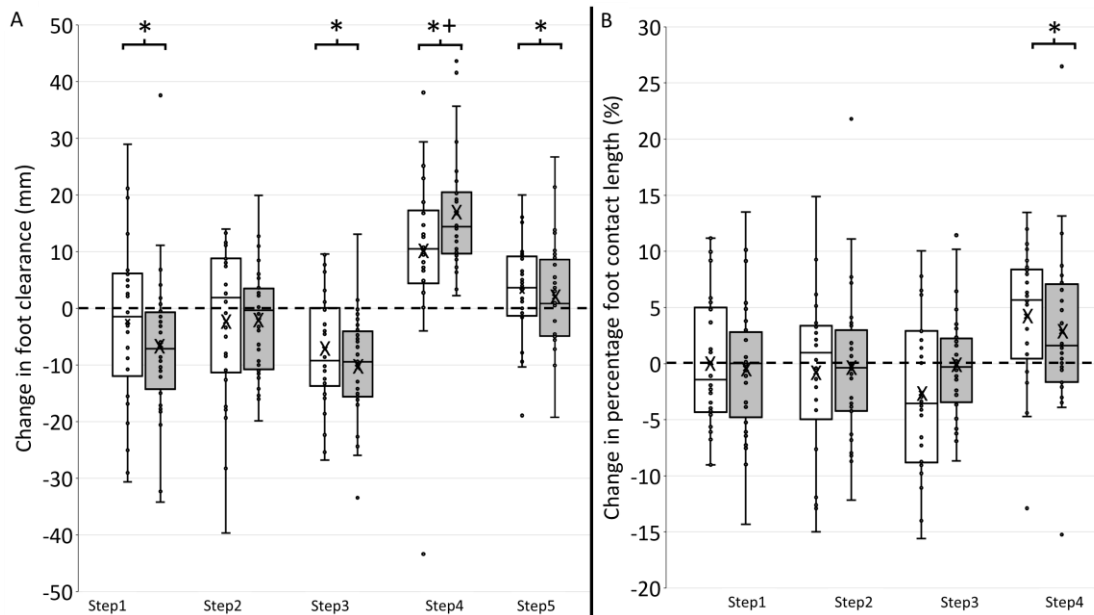

Figure 3.2. Stair ascent A), change in vertical foot clearance from the step-edge and B), change in percentage foot contact length on each step, from consistent to inconsistent rise condition (Step3 10 mm higher), a negative value represents a reduction and thus increased level of risk during the inconsistent rise condition compared to the consistent condition. — = No/zero change, X represents group mean, □ = younger adults, □ = older adults. A two by two-repeated mixed methods ANOVA was run on values recorded for foot clearance and foot contact, during the consistent and inconsistent rise conditions for younger and older adults. * = stair condition effect where differences between consistent and inconsistent rise condition exist, + = interaction effects between stair condition and age group; $p < 0.05$, all significance levels reported at the significance level $p \leq 0.05$.

3.5.2 Ascent secondary analysis.

To understand how foot clearances over Step3 became smaller on the inconsistent higher rise, SPM was used to compare the trajectory of the foot CoM on the approach to Step3. On average for both groups ($N = 13$), foot CoM trajectories were not significantly different between conditions up to the point that the foot passes the step-edge of Step3 (~75% of swing, Figure 3.3). Significant differences between conditions emerged only on the approach to contact ($p = .019$), after 88% of swing.

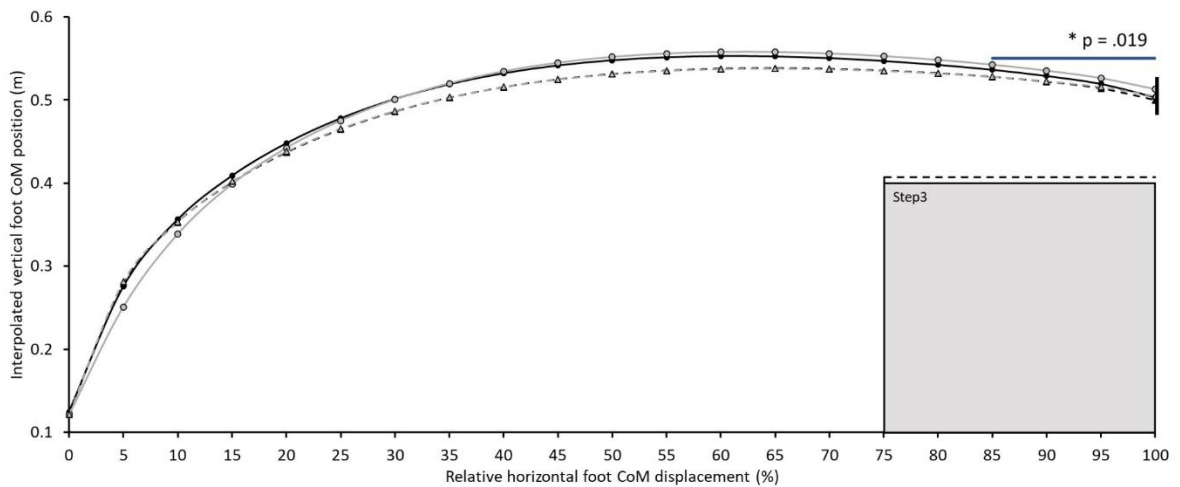

Figure 3.3. Stair ascent, vertical trajectory of the CoM of the foot relative to the total horizontal displacement travelled during swing from toe off Step1 until before touch down on Step3 (same relative vertical position irrespective of stair dimensions). Trajectories are shown at 5% intervals. —●— = younger adults consistent condition, -○- = younger adults inconsistent rise, —▲— = older adults consistent condition, -△- = older adults inconsistent rise, | = end of SPM analysis (vertically similar point in space). Foot position was only significantly different between condition after 85% of displacement —, $p = .019$ ($N = 14$ per group). Step3 edge vertical position in consistent condition = 0.401 m and inconsistent condition = 0.412 m.

3.5.3 Stair descent.

For the first inconsistent descending trial, the data of one younger adult were excluded from the analysis due to missing force data. There were no known occurrences of slips or trips during descent. There were the occasional heel marker catches on the underneath of the steps during terminal stance (pre-swing), the marker would then snap off its attachment to the shoe. Because movement continued, it was not thought to disrupt the natural foot trajectory so remained included in the analysis. The posterior calcaneus marker was not used in the processing of foot clearances but was included in the foot CoM calculations. The marker protruded 14 mm backward from the participant's shoe and may have caused increases in clearances for some participants as this was the same for both conditions, we do not believe it had a large impact on results.

During descent on the consistent stairs, on average older adults had greater foot clearance and larger variability over the steps (Land-Step2) (26 ± 11 mm) than the younger

adults (20 ± 8 mm, $p = .035$) and also had a greater percentage foot contact length (Step4-Step1) ($85.7 \pm 7.4\%$) compared to the younger adults (81.0 ± 6.4 , $p = .015$, Appendix D).

Percentage foot contact length decreased on the inconsistent higher Step3 by $\approx 2\%$ ($p = .004$) for both the younger (consistent: $81.3 \pm 6.4\%$, inconsistent rise $79.8 \pm 8.4\%$) and older adults (consistent: $85.5 \pm 7.7\%$, inconsistent rise: $83.4 \pm 9.1\%$). Foot contact length then increased on Step2 by $\approx 4\%$ ($p < .001$), for the younger adults (consistent condition: $81.1 \pm 7.2\%$, inconsistent rise $85.5 \pm 7.3\%$) and the older adults (consistent: $85.3 \pm 8.4\%$, inconsistent rise: $89.1 \pm 9.3\%$). Additionally there was an interaction between stair condition and age group on Step4 ($p = .016$), whereby foot contact length on Step4 prior to experiencing the inconsistent steps in the inconsistent rise condition increased for younger adults by $\approx 2\%$ (consistent: $79.3 \pm 7.0\%$, inconsistent rise: $81.5 \pm 9.0\%$) but not for the older adults (consistent: $84.5 \pm 9.1\%$, inconsistent rise: $84.0 \pm 10.2\%$) (Figure 3.4 Part B). There were no significant changes in foot clearances for either group during descent of the inconsistent stairs compared to the consistent condition (Figure 3.4 Part A and Appendix D).

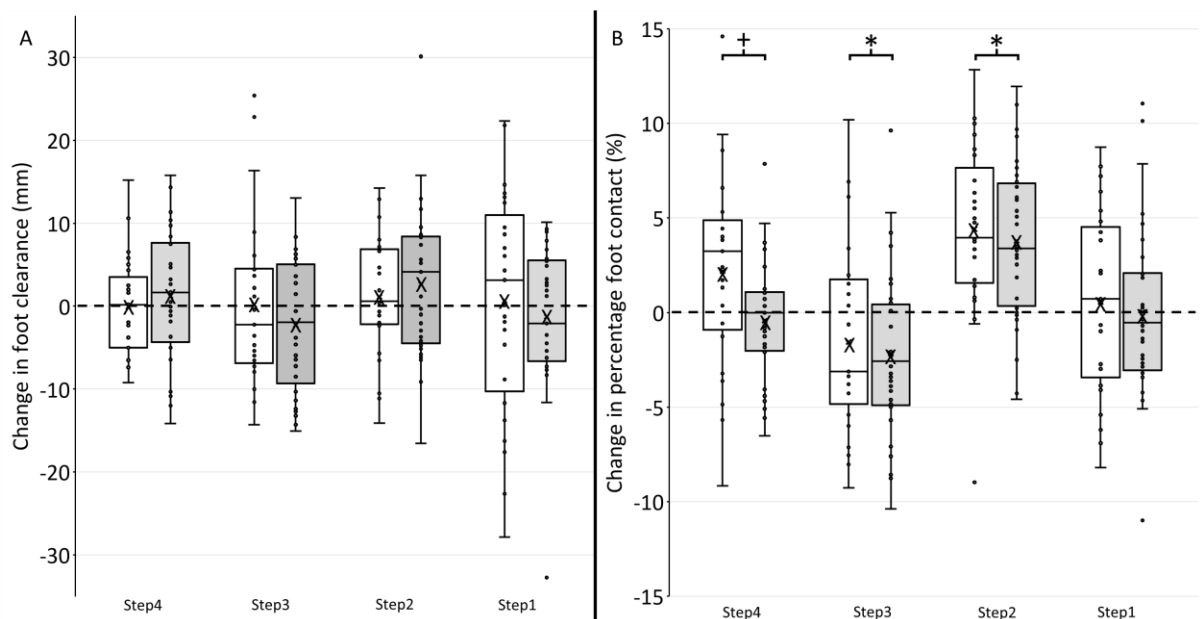

Figure 3.4. Stair descent A), change in horizontal foot clearance from the step-edge and B), change in percentage foot contact on each step, from consistent to inconsistent rise condition (Step3, 10 mm higher), a negative value represents a reduction and thus increased level of risk during the inconsistent rise condition compared to the consistent condition. — = No/zero change, X represents group mean, □ = younger adults, ■ = older adults. A two by two repeated mixed methods ANOVA was run on actual values recorded for foot clearance and foot contact, during the consistent and inconsistent rise conditions for younger and older adults. * = stair condition effect where differences between consistent and inconsistent rise condition exist, + = interaction effects between stair condition and age group; $p < 0.05$, all significance levels reported at the significance level $p \leq 0.05$.

3.5.4 Descent secondary analysis.

To help understand how percentage foot contact length decreased on the inconsistent higher Step3 (smaller rise) during descent, additional analyses were performed to test whether foot trajectories were different between conditions. To achieve similar time and space normalisations for both conditions, the consistent foot CoM trajectory from Step5 to Step3 was trimmed 1 cm vertically higher than its position the instant before contact on Step3. This end point represents the same vertical position in space as the inconsistent rise trajectory curve.

We first determined if the horizontal foot CoM positions the instant before contact on Step3 were different between the consistent condition 10 mm vertically higher and the inconsistent higher rise step. A two-way repeated measures ANOVA did not find differences between the horizontal foot CoM positions at this crucial time point for the younger adults (consistent: 46 ± 14 mm vs Inconsistent: 47 ± 18 mm) or the older adults (consistent: 65 ± 17 mm vs inconsistent: 65 ± 19 mm).

An SPM analysis (N = 25 for each group) of the horizontal foot CoM trajectories to the same vertical position end point, revealed that despite differences between stair conditions early to mid-swing (9-48%, $p = .006$), after mid-swing foot trajectories were not significantly different between conditions and were not different when passing the step-edge of Step4 (between 75-80% of swing, explaining similar clearances at this point) or until the end of the analysis (Figure 3.5).

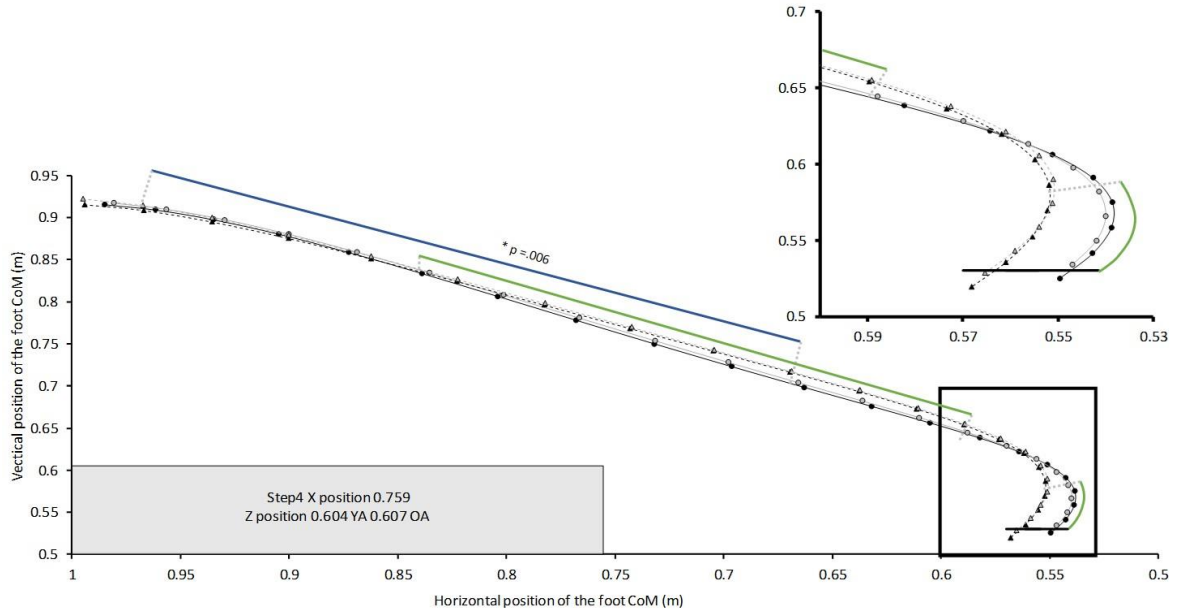

Figure 3.5. Stair descent horizontal and vertical trajectory of the foot CoM. Data are time normalised from toe off Step5 until one frame before contact on Step3, data points are sampled at every 5% of swing. —●— = younger adults (YA) consistent condition, —○— = younger adults inconsistent rise, —▲— = older adults (OA) consistent condition, —△— = older adults inconsistent rise, — = end of SPM analysis (similar vertical point in space), — = horizontal position was significantly different between conditions at 9-48% ($p = .006$), — = an age effect was present in horizontal position between 27.8% - 61.5% and after 83.5%, $p < .05$. Vertical position was not significantly different.

3.6 Discussion

This study was the first to experimentally document the mechanisms by which fall risk and occurrences are increased when negotiating stairs with an inconsistently higher rise. As hypothesised and consistent with previous theoretical literature (Nemire et al., 2016; Roys, 2013; Templer, 1992), neither the younger nor older adults tested in this study altered their stepping behaviour substantially prior to stepping onto an inconsistent step rise. Consequently, individuals were at an increased risk of tripping on the step with an increased rise in ascent and overstepping on the step following a reduced rise in descent.

Results from the consistent stairs (Appendix D) confirmed existing knowledge that older adults typically appeared to use more cautious stepping strategies, with greater foot contact lengths compared to the younger adults. Despite differences in behaviour

observed between the two age groups, the effect of the inconsistent rise was similar for the older and younger adults (no age x condition interactions were detected). Therefore, it is expected that both groups would be at an increased fall risk and by the same mechanisms, on stair with inconsistent rise heights. However, it is likely that the consequences will be more severe for the older adults (Foster et al., 2019) as they do not have the adequate strength reserves to recover should they lose balance (Pijnappels, Reeves, et al., 2008; Reeves et al., 2008b). It has previously been reported that poor lighting conditions (Kim, 2009; Thomas et al., 2020) and dual-tasking such as talking on the phone (Di Giulio, McFadyen, et al., 2020) can further compromise stepping mechanics, these factors could be detrimental to safety and may inhibit good balance control when navigating stairs with inconsistent dimensions.

3.6.1 Stair ascent.

During ascent, vertical foot clearances over the inconsistent higher Step3 were reduced on average by 8-10 mm, close to the 10 mm manipulation of height change made, increasing the risk of a toe-catch, whereas foot contact lengths were not significantly different. Therefore, only the first part of Hypothesis 1. was accepted. Secondary analysis revealed that the reduced clearance occurred because the foot followed a similar trajectory through space even though the edge of Step3 was higher (Figure 3.3). This would increase the risk of a toe-catch and fall due to tripping, which was evidenced during our experiments when three older participants each experienced one toe-catch event during their inconsistent rise ascents. All three participants were able to regain their balance without assistance from the handrails or support from the safety system and continued to ascend the stairs. Weaker or distracted individuals in non-laboratory situations may not be able to recover their balance and may experience a serious fall.

3.6.2 Stair descent.

During stair descent, foot contact lengths on the step following the inconsistent smaller rise (on Step3 which had been moved up) were reduced. However, foot clearances

did not significantly differ. Therefore, only the first part of Hypothesis 2 was accepted. The reason for this reduced contact length can, like ascent, be attributed to the lack of change in the foot's trajectory after passing the step-edge of Step4 despite the surface of Step3 being higher. Younger adults did show a slight increase in percentage foot contact length on Step4 (Figure 3.4) prior to the inconsistency which resulted in small horizontal position changes to foot the trajectories in the first half of swing off Step5 (Figure 3.5), it is not clear why younger adults made these changes but their movements were within normal range at the critical point of passing Step4 edge horizontally. The mechanism is more complex than ascent. The terminology of stair descent often describes movement as forwards and downwards during swing (Templer, 1992). Although the foot does follow this path for a large portion of swing, our descent trajectories (Figure 3.5) and the work of Pauls (Pauls, 2013) visualise that the foot actually moves backwards during late swing. As a result, when the foot travels on the same trajectory but hits the higher inconsistent step sooner and out of place, there was less time and space for the foot to travel backwards along the expected path compared to the consistent condition, resulting in a reduced foot contact length.

This reduced foot contact length increases the chances of over-stepping and the potential for a slip forwards over the edge (Templer, 1992) causing a backward loss of balance (Nicol, Roys, Garrett, & BRE, 2011; Roys, 2001, 2013; Templer, 1992). A recent paper has documented the types of fall recovery used by young adults when a backward loss of balance was induced (Gosine et al., 2019), not all individuals were able to achieve a successful handrail grab, but did use at least one additional step to regain control of balance, this could increase the demand on lower-limb muscles to arrest the fall (Gosine et al., 2019). A loss of balance at this point is likely to cause a backward fall, concussion and serious fractures (Jacobs, 2016; Templer, 1992).

A 10 mm smaller rise in descent (stepping down on Step3) led to an average 5 mm reduction in contact length. This presents the same risk and hypothesised fall mechanism as a similar magnitude reduction in step going length, which has previously been considered to be most risky during decent (Roys, 2001, 2013). According to the literature

on reducing going length, this 5 mm reduction in contact length is predicted to increase the likelihood of a large over-step by as much as 4.5-fold (Roys 2013). More empirical research is required to determine the true level of risk on stairs with inconsistencies, but this finding demonstrates that inconsistencies in step rise should be treated as seriously as inconsistencies in going.

The analyses in this chapter present comparisons between negotiation of consistent stairs and the first trial on the inconsistent stairs. This approach was chosen to avoid a potential learning effect confounding our comparisons. However, in many situations, such as at home, individuals will use the same stairs multiple times and a learning effect may be possible to mitigate the risky inconsistent step. To test this, we conducted a further exploratory analysis of stepping behaviours of 24 of the younger adults and 20 of the older adults when ascending and when descending the inconsistent stairs a total of five times. Specifically, foot contact lengths on Step3 in descent and clearance of Step3 in ascent were quantified as these were the parameters that increased the risk of a fall. We found no changes in either parameter across repeated trials on the inconsistent stairs (Figure 3.6). These additional analyses support the primary findings of the chapter and indicate that neither older nor younger adults adapted their stepping behaviours to improve safety even after multiple exposures to inconsistent rise heights. This goes even further than previous work which hypothesised that inconsistencies would remain undetected until they were contacted (Roys, 2001, 2013; Roys & Wright, 2005; Templer, 1992). It is not yet known if longer-term exposures would lead to adaptations.

In addition to the inconsistencies that increased fall risk, which have been discussed thus far, in ascent a smaller rise led to an increased foot clearance (over Step4) and in descent a larger rise increased foot contact length on the following step (Step2). Both of these effects would decrease the risk of a fall on those steps. According to the additional analyses (described in preceding paragraph), these effects persisted across multiple trials. However, we do not know whether they might cause a negative effect on subsequent steps and this should be studied in future work to fully understand the risks associated with stair inconsistencies.

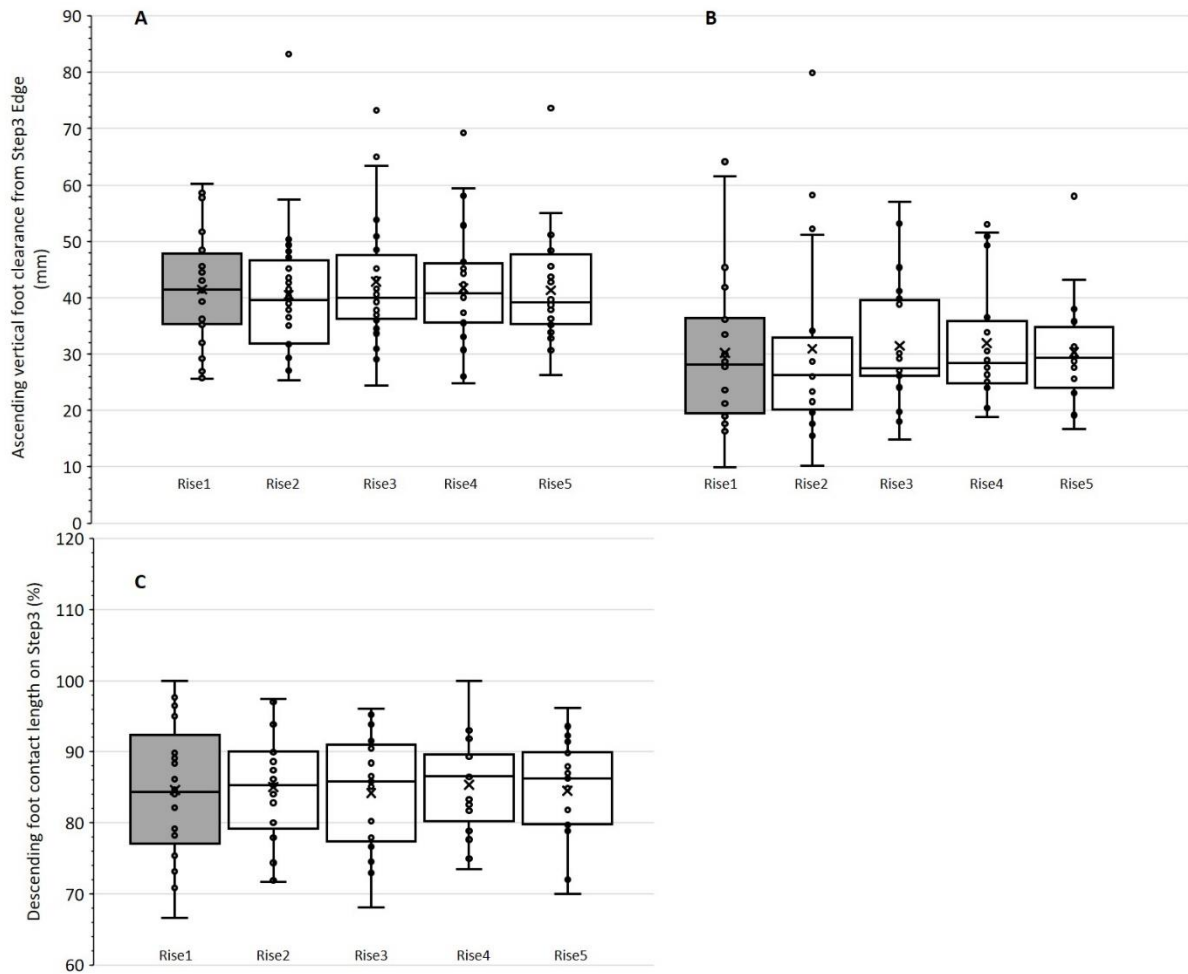

Figure 3.6. The effect of repeated trials negotiating stairs with inconsistent rise heights (Step3) on A) young adults' foot clearance in ascent, N= 24; B) older adults' foot clearance in ascent, N= 20 and C) older adults' percentage foot contact during descent, N = 20. Repeated measures ANOVAs detected no significant differences between repeated rise trials ($p > 0.05$ for all).

3.6.3 Implications.

We have evidenced that inconsistencies in rise height even greater than those permitted within the regulations but in line with those observed on real stairs (J. Cohen et al., 2009), seem to go undetected putting the users at an increased risk because foot trajectories are not adapted accordingly. In order to reduce the risk it may be necessary to: control compliance to legislation including remodelling of stairs with large inconsistencies (Nicol et al., 2011), manipulating the visual environment to alert users to the inconsistency, such as strategically placed highlights or visual illusions may encourage

changes to the stepping behaviour (Foster, Whitaker, Scally, Buckley, & Elliott, 2015), or promote long-term safer stepping strategies. All these options would require experimental research to establish potential benefits but will be discussed in more detail within the Chapter 6 General Discussion.

On completion of the study, when prompted older participants were not able to correctly identify the changes or note the specific steps that had inconsistencies when they were asked. The most common response was that they thought something felt different towards the bottom of the stairs. So even after five ascents and descents, individuals were not really aware of the inconsistencies and therefore are not likely to make appropriate changes to their stepping behaviour on rise inconsistencies of this magnitude or smaller unless prompted or visually tricked to do so. It is not yet known which magnitude of rise inconsistency can be noticed, but larger magnitudes will likely further increase the risk of trip or slip for the individual if they are not seen in advance.

The whole-body response and dynamic control of the CoM after contact with the inconsistent higher rise step will be explored in Chapter 5. However future research is required to determine whether the negative effects observed for a higher rise, persist in habitual stair use, or if improvements might occur, indicating a learning effect. There were some general limitations to this chapter which are included in Chapter 6 General Discussion but there were no additional limitations specific for this chapter.

3.7 Conclusion

When approaching a step with an inconsistent rise than the rest of the stairs, the foot trajectories did not differ from the consistent condition for older or younger adults. This suggests that the inconsistency was undetected, which increased the risk of a toe-catch on the step with a higher rise in ascent and a risk of over-stepping on the step after a smaller rise in descent, both increasing the likelihood of a fall. These mechanisms underpin the interactions between stairs and human behaviour. The findings indicate the importance of designing, constructing and installing stairs with consistent risers. Given inconsistencies already exist in many environments, it is necessary to identify occurrences

and the magnitude of those inconsistencies, as well as establish safety promoting interventions.

Chapter 4:

Biomechanics of Stepping on Stairs with an Inconsistent Going

Elements of this chapter were presented at conferences including:

Francksen N, Ackermans T, Holzer D, Maganaris C, Hollands M, Roys M, O'Brien T. (2018). Inconsistencies in staircase dimensions impact upon stair climbing safety. Paper presented at 42nd Annual Meeting of the American Society of Biomechanics, Rochester, Minnesota, USA, 2018. (Competing in the ASB Student Award).

Francksen N, Ackermans T, Holzer D, Maganaris C, Hollands M, Roys M, O'Brien T. (2018) Stair descent: the influence of inconsistent going step dimensions on younger and older adults' safety. Poster presented at the 8th World Congress of Biomechanics, Dublin, Ireland, 2018.

Francksen N, Ackermans T, Holzer D, Maganaris C, Hollands M, Roys M, O'Brien T. (2018) The effect of an inconsistent going during stair ascent & an inconsistent rise during stair descent. Paper presented at the BASES Biomechanics Interest Group (BIG) meeting, Salford, UK, 2018.

4.1 Introduction

The length of the horizontal going of a step is thought to be an important factor determining the risk of falling on stairs, particularly during descent (Wright & Roys, 2008); which is thought to lead to more frequent and serious injuries (Jacobs, 2016; Startzell et al., 2000). Shorter goings result in smaller foot clearances and greater overhangs in both ascent and descent particularly for older adults (Di Giulio, Reeves, et al., 2020). Reduced foot contact with the step surface increases under or over-stepping which may lead to a slip (Roys, 2001, 2013; Roys & Wright, 2005; Templer, 1992; Wright & Roys, 2005). Additionally, when descending steps with short goings, the metatarsal region, which is important for proprioceptive feedback to guide gait and control balance (Hale and Glendon, 1987; as cited by Templer, 1992), is more likely to overhang the step-edge. Consequently, proprioceptive signals received from the feet may be compromised creating more variable gait, which could compromise balance control (Novak et al., 2016) increasing the risk of a loss of balance (Roys, 2013; Wright & Roys, 2008).

A survey in the UK documented that 40% of stairs did not comply with the minimum going dimension regulations and that there were large inconsistencies between steps of up to 25 mm in going (Wright & Roys, 2008). Disturbingly, the variability in dimensions found in the survey are larger than the more generous 9.5 mm limit that is permitted across the whole flight in the USA (NFPA 101, 2000). This problem seems universal, as in a study in the USA, out of 80 cases, 34% had going dimensions that were greater than the permitted limit (J. Cohen et al., 2009). The frequent occurrence of inconsistent going dimensions is thought to expose users to falls risks like that of smaller but consistent goings (Roys, 2013; Roys & Wright, 2005; Wright & Roys, 2008).

Investigators have assumed that stair users do not detect steps with an inconsistent going on stairs and so do not adjust their stepping strategy. This has led to the hypothesis that the high fall rates occur because stair users are more likely to overstep on the inconsistent step and therefore the potential for a slip is increased (J. Cohen et al., 2009; Roys, 2013; Wright & Roys, 2008). Authors have hypothesised that inconsistent

shorter goings during descent may also increase the number of heel catches or trips on the inconsistent step-edge during swing (Roys, 2013; Wright & Roys, 2008) and could influence foot clearances on subsequent steps (Roys, 2013). Heel scuffs on the vertical riser may happen more often on a step with inconsistently shorter going, as heel scuffs are more likely to occur on stairs with narrow goings or larger noses (Pauls, 2013). In ascent, an inconsistent shorter going could result in toe-catches or under-stepping (Templer, 1992). However, these hypotheses are generated from theoretical calculations using normal movement, expected variability and the assumption that people do not detect inconsistencies and therefore do not change their behaviour (Roys, 2013).

The work presented in Chapter 3 found that older and younger adults did not adjust stepping trajectories on a staircase with an inconsistent rise, suggesting that they did not detect the inconsistency. At present the estimations for level of risk for variable goings are based on the same assumptions, i.e. that people do not change their stepping behaviour over the inconsistencies and consequently will have poorer stepping mechanics on the inconsistent going step which may also have repercussions on subsequent stepping mechanics. However, this has not been experimentally tested and so the proposed mechanisms by which falls occur remains theoretical. Until these assumptions are tested, attempts to improve stair safety through improved staircase design or behavioural interventions will lack specificity.

Therefore, the aim of this experimental chapter was to identify the mechanisms by which steps with inconsistent going dimensions increase the risk of a toe- or heel- catch (trip) or overstep (slip) and to determine whether these risks are different between younger and older adults.

4.2 Hypothesis 1

In stair descent, on the step with an inconsistently shorter going, there will be a reduced percentage foot contact length on the step and subsequent foot clearances on steps below may also be reduced.

4.3 Hypothesis 2

In stair ascent, on the step with an inconsistently shorter going percentage foot contact length will decrease on the inconsistent step whereas foot clearances are likely to increase over the inconsistent step.

4.4 Methods

The general methods for the collection and analysis of the data presented in this chapter have already been described in detail in Chapter 2. Since the aims of this experimental chapter are to quantify the effects of inconsistent goings on stepping mechanics, only comparisons between the consistent condition (Figure 4.1 a) and the inconsistent going condition are considered. In summary, an inconsistently shorter going was created by moving the third step from the bottom up (Step3) inwards by 10 mm. All riser heights were 200 mm and had an overall pitch of 38.7°. As a consequence of moving Step3 inwards, Step2 going length was subsequently increased by 10 mm (Figure 4.1 b).

Data from at least three trials were averaged (five where possible, average number of trials = 4.7 ± 0.6) for the consistent dimension condition and the first trial only was analysed for the inconsistent going condition. Trials with incomplete force data or long periods of occluded markers were excluded from the analysis. Participants always ascended before they descended the stairs. The main outcome measures of interest for this chapter were foot clearance and percentage foot contact length, which are defined in section 2.8 of Chapter 2. Participants were asked, on completion of the study, if they knew whether and how the staircase was altered.

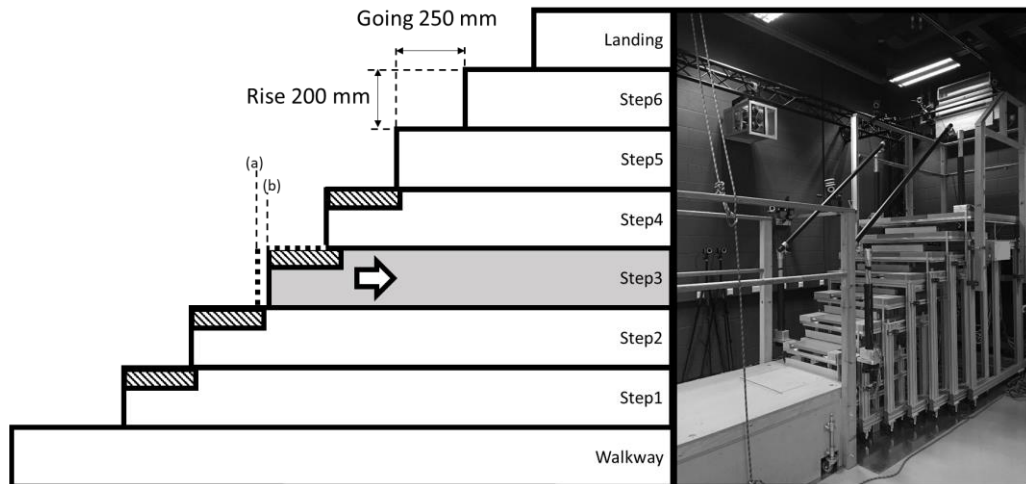

Figure 4.1. Seven-step staircase, with four force plates located in Step1-4. For the consistent condition (a) all steps had a had a going of 250 mm and a rise height of 200 mm, for the inconsistent going condition (b) only Step3 was moved 10 mm inwards, increasing Step2 going to 260 mm and thus reducing Step3 going to 240 mm, all other steps remained the same.

4.4.1 Statistical analysis.

Primary analyses of the two outcome measures were performed using a 2-way mixed method Analysis of Variance (ANOVA) design for ascent and descent. Percentage foot contact length (Step4-1) and foot clearance (Landing-Step1) were included in the multivariate analysis. Comparisons were made, between each condition (consistent versus inconsistent going stairs) and between the two age groups (younger versus older adults) with an alpha level set to $p \leq 0.05$ at the univariate level, meaning that data from each step were analysed independently of the other, considering that some contacts/clearances may be increased while others decreased.

One-dimensional statistical parametric mapping (SPM, Pataky, 2012) was used to compare the 3D kinematic trajectories of the foot CoM on the approach to the inconsistent steps and away from them. Foot CoM trajectories were obtained during swing between toe-off and one frame before initial contact on the next step, irrespective of condition. The vertical position of the foot was similar at initial contact in both conditions. To comply with the balanced design required between groups and condition

for a two by one-way ANOVA SPM, participants from the older adult group were randomly excluded. This was done by allocating each participant a number when they first entered the lab and those identified by a computer-based random number generation algorithm were excluded was used to fairly exclude the appropriate number of older adults from the analysis. To ensure the random selection produced similar results, this process was repeated five times. Each repeat analysis produced similar results, consequently we report results from the first analysis.

Additional two-way Repeated Measures ANOVAs were also used to determine change in global coordinate positions of the Foot CoM and determine step length irrespective of step-edge location in the two conditions, these analyses helped to quantify the differences in stepping behaviour found between the younger and older adults in the consistent and inconsistent going conditions.

4.5 Results

Out of twenty-seven younger adults (24 ± 3 yrs, 1.74 ± 0.09 m, 71.41 ± 11.04 kg) and thirty-three older adults (70 ± 4 yrs, 1.68 ± 0.08 m, 67.90 ± 14.10 kg). Two younger adults were excluded from the analysis during descent due to issues with force acquisition in the shorter going condition. One older adult was excluded from the ascent analysis because a foot marker fell off during the first ascending trial of the inconsistent going condition, this was rectified before the first descent.

4.5.1 Stair descent.

During descent on the consistent stairs, on average older adults had greater foot clearance over the steps (Land-Step2) (26 ± 11 mm) than the younger adults (20 ± 8 mm, $p = .035$) and also had a greater percentage foot contact length (Step4-Step1) ($85.7 \pm 7.4\%$) compared to the younger adults (81.0 ± 6.4 , $p = .015$, Appendix E).

During descent, compared to the consistent condition, foot clearances (mean \pm standard deviations) were increased over the inconsistent shorter Step3 ($p < 0.001$) by ≈ 7 mm for the younger adults (consistent: 17 ± 10 mm, inconsistent going 24 ± 15 mm) and

by ≈ 4 mm for the older adults (consistent: 26 ± 14 mm, inconsistent going: 30 ± 17 mm), and decreased over the longer Step2 ($p = .027$) by ≈ 5 mm for the younger adults (consistent: 21 ± 9 mm, inconsistent rise: 16 ± 11 mm) and < 1 mm for the older adults (consistent: 23 ± 12 mm, inconsistent 23 ± 18 mm) (Figure 4.2 Part A), no interactions were present between age and condition for foot clearances.

Compared to the consistent condition foot contact lengths were not different on Step4 prior to the shorter inconsistent step, nor when contacting the shorter inconsistent Step3 for younger (consistent: $81.3 \pm 6.4\%$, inconsistent going: $80.4 \pm 5.4\%$) and older adults (consistent: $85.5 \pm 7.7\%$, inconsistent going: $84.4 \pm 9.4\%$), indicating that an alteration to the stepping occurred to achieve this. Foot contact lengths then significantly increased on the longer Step2 by $< 2\%$ ($p = .005$) for the younger (consistent: $81.1 \pm 7.2\%$, inconsistent going: $82.9 \pm 6.6\%$) and the older adults (consistent: $85.3 \pm 8.4\%$, inconsistent going: $87.2 \pm 9.3\%$). There was an interaction effect for foot contact lengths on Step1 ($p = .004$) and condition effect ($p < .001$) whereby the foot contact lengths increased by $\approx 4\%$ for the younger adults (consistent: $82.5 \pm 6.3\%$, inconsistent going: $86.5 \pm 6.7\%$) but $< 1\%$ for the older adults (consistent: $87.2 \pm 6.9\%$, inconsistent going: 88.0 ± 8.0 (Figure 4.2 Part B)).

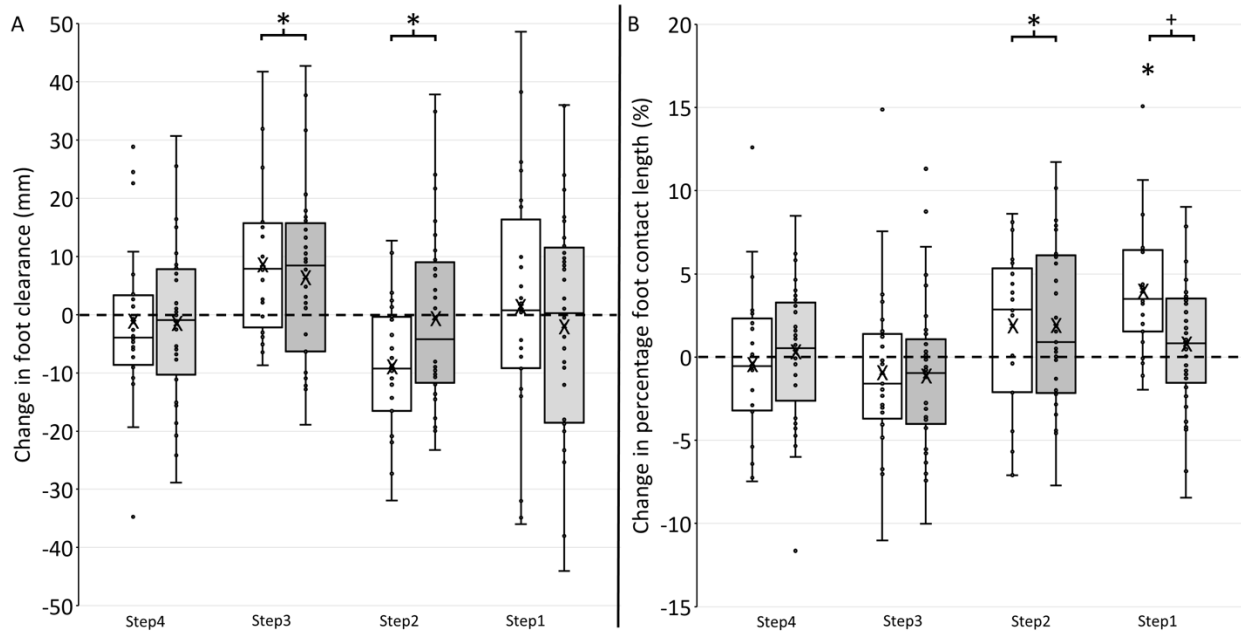

Figure 4.2. Stair descent A) change in horizontal foot clearance from the step-edge and B) change in percentage foot contact length on each step, from consistent to inconsistent going condition (Step3 10mm shorter), a negative represents a reduction and thus an increased level of risk during the inconsistent going condition compared to the consistent condition. — = No/zero change, X represents group mean, □ = younger adults, □ = older adults. A two by two-repeated mixed methods ANOVA was run on values recorded for foot clearance and foot contact, during the consistent and inconsistent going conditions for younger and older adults. * = stair condition effect where differences between consistent and inconsistent rise condition exist, + = interaction effects between stair condition and age group; $p < 0.05$, all significance levels reported at the significance level $p \leq 0.05$.

Further analyses were performed to understand how both younger and older adults maintained foot contact length on Step3, despite this step having an inconsistently shorter going. SPM (Pataky, 2012) analyses ($N = 25$ per age group) were used to compare the horizontal and vertical position of the Foot CoM trajectories during swing on the approach to Step3 in the consistent and inconsistent condition (toe-off from Step5 until 1 frame before contact with Step3). The horizontal trajectory differed between conditions after 78% of swing (the Foot CoM passed Step4 edge at ~70% of swing). From this point onwards the Foot CoM trajectories for both groups were more posterior, closer to the stairs compared to the consistent condition ($p = .025$) (Figure 4.3). There were differences detected between the younger and older groups, but these were consistent with normal stepping biomechanics (30-54% and after 75% of swing) and there were no interaction effects detected (Figure 4.3). No differences were detected for the vertical trajectories.

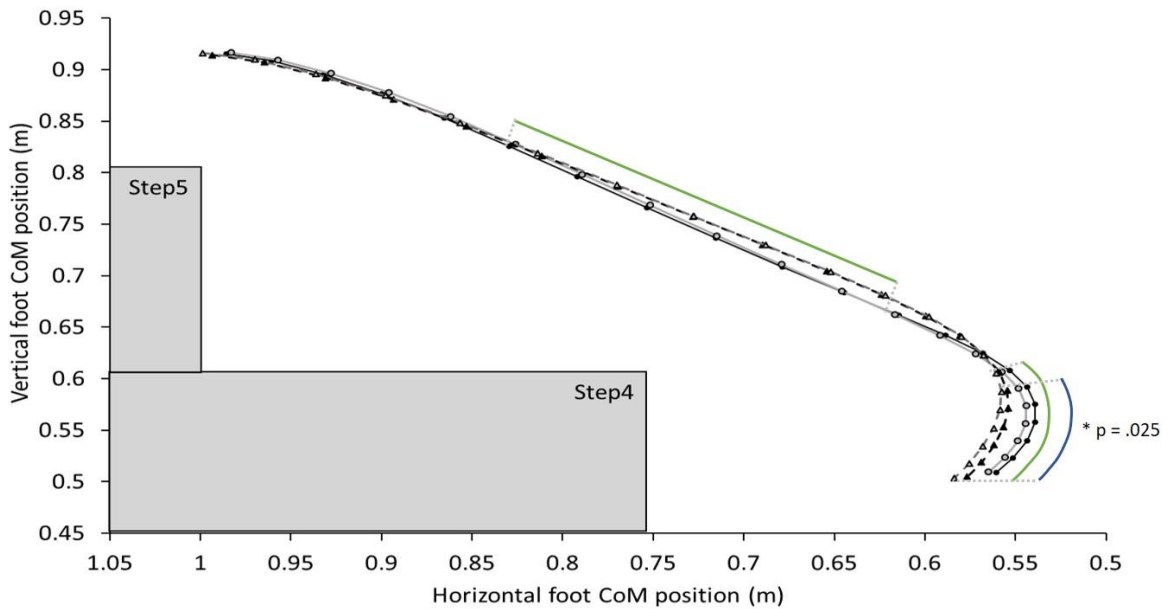

Figure 4.3. Stair descent horizontal and vertical trajectory of the foot CoM. Data are time normalised from toe off Step5 until one frame before contact on Step3, data points are sampled at every 5% of swing. —●— = younger adults (YA) consistent condition, —○— = younger adults inconsistent going, —▲— = older adults (OA) consistent condition, —△— = older adults inconsistent going, — = horizontal position was significantly different between conditions after 78% of swing ($p = 0.025$), — = an age effect for horizontal position was present between 30-54% and after 75% of swing $p < .05$. Vertical position was not significantly different.

SPM analysis was then used to help understand why younger adults had a reduced clearance over Step2 (longer step) but older adults did not. As the two groups had a foot position further back in space on Step3 in the going condition compared to the consistent condition, change in horizontal displacement of the foot CoM was used in the SPM analysis (instead of position coordinates which are visually represented in, Figure 4.4). Trajectories were compared from toe-off Step3 until one frame before contact on Step1. No differences in the stepping trajectories were found between the two staircase conditions. An age effect was noted between 16-52% of swing but not at the point of, or after, passing the step-edge.

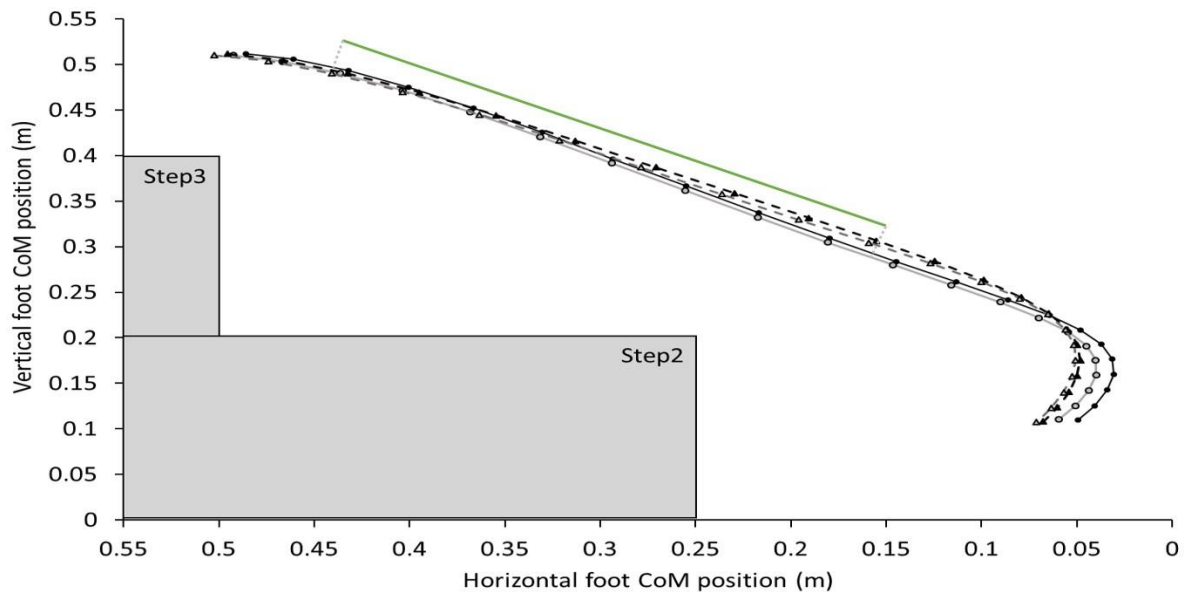

Figure 4.4. Stair descent horizontal and vertical position trajectory of the foot CoM. Data are time normalised from toe off Step3 until contact on Step1, data points are sampled at every 5% of swing. —●— = younger adults (YA) consistent condition, -○- = younger adults inconsistent going, -▲- = older adults (OA) consistent condition, -▲- = older adults inconsistent going, — = an age effect was present between 16-52%, $p < .05$.

4.5.2 Stair ascent.

On the consistent stairs, on average older adults' foot clearances did not significantly differ over the steps (Steps2-6) (39 ± 15 mm) compared to the younger adults' (37 ± 9 mm, $p = .568$). Older adults did have a significantly greater percentage foot contact length ($76.7 \pm 10.2\%$) compared to the younger adults ($67.4 \pm 10.1\%$, $p = .001$, Appendix E).

Compared to the consistent condition, during ascent of the inconsistent stairs, foot clearances were significantly different over the inconsistently shorter Step3, where vertical clearances increased ($p = .009$) by ≈ 4 mm for the younger adults (consistent: 41 ± 10 mm, inconsistent going: 45 ± 14 mm) and by ≈ 2 mm for the older adults (consistent: 42 ± 18 mm, inconsistent going: 44 ± 19 mm). Clearances were also increased between 2-4

mm for both groups over Step6 and the Landing step-edge. No interactions between age and condition existed for the foot clearances.

There were a series of significant interactions detected between conditions and age groups for the percentage foot contact lengths on the inconsistently longer Step2 ($p = .003$), on the inconsistently shorter Step3 ($p = .004$) and on Step4 ($p = .006$) (Figure 4.5). Compared to the consistent condition, on Step2 post-hoc analyses revealed that younger adults stepped with $\approx 6\%$ more foot contact ($p < 0.001$) in the inconsistent going condition (consistent: $67.3 \pm 10.1\%$, inconsistent going: $73.0 \pm 10.6\%$) whereas older adults had no change ($p = .638$, consistent: $77.5 \pm 11.1\%$, inconsistent going: $78.0 \pm 11.6\%$). On Step3 the reverse occurred, whereby foot contact was not significantly different for the younger adults (consistent: $66.8 \pm 10.2\%$, inconsistent going: $69.0 \pm 9.8\%$) although it was increased by $\approx 2\%$ ($p = .068$) but was significantly reduced by $\approx 2.8\%$ ($p = .026$) for the older adults (consistent: 76.3 ± 10.7 , inconsistent going: $73.5 \pm 10.9\%$). On Step4 the results flipped again, younger adults had $\approx 8\%$ ($p < .001$) greater foot contact lengths (consistent: $64.1 \pm 10.2\%$, inconsistent going: $72.1 \pm 10.9\%$), whereas older adults did not have significant increases ($p = .116$, consistent: $74.9 \pm 11.6\%$, inconsistent going: $77.2 \pm 12.9\%$)(Figure 4.5 Part B).

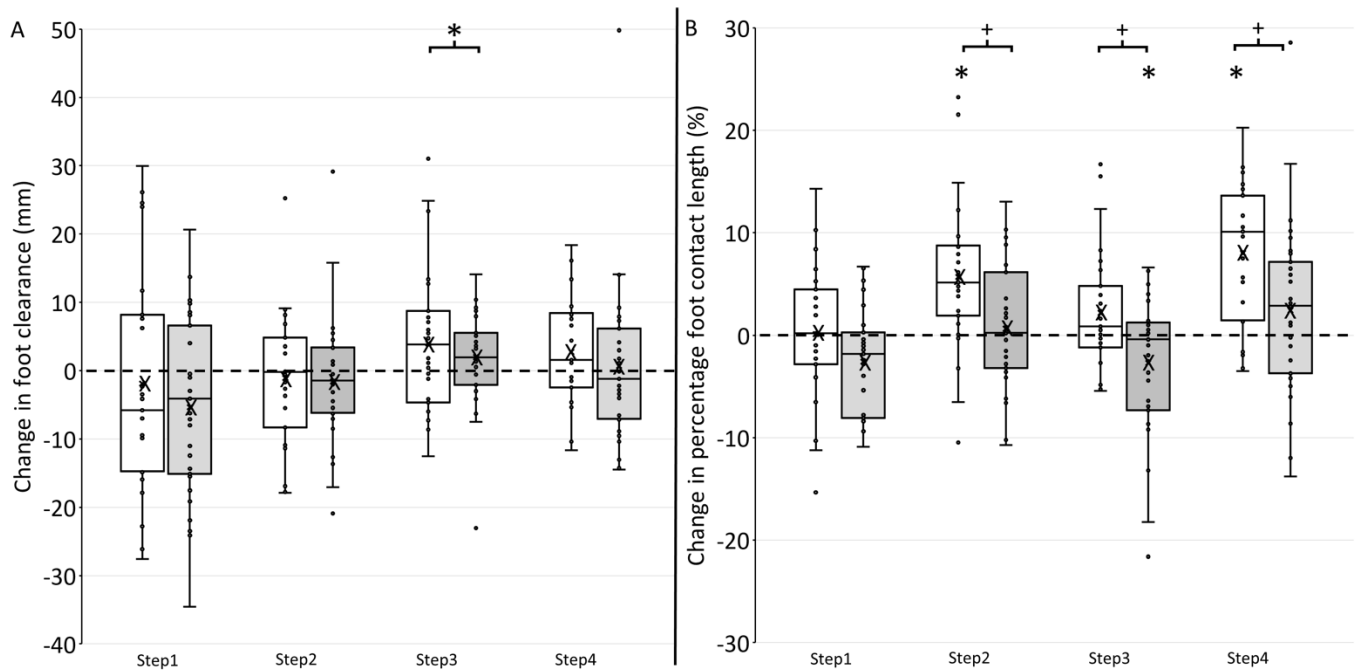

Figure 4.5. Stair ascent A) change in horizontal foot clearance from the step-edge and B) change in percentage foot contact length on each step, from consistent to inconsistent going condition (Step3 10 mm shorter), a negative represents a reduction and thus an increased level of risk during the inconsistent condition. percentage change in foot contact on each step, from consistent to inconsistent going condition. — = No/zero change, X represents group mean, □ = younger adults, □ = older adults. A two by two-repeated mixed methods ANOVA was run on values recorded for foot clearance and foot contact, during the consistent and inconsistent going conditions for younger and older adults. * = stair condition effect where differences between consistent and inconsistent rise condition exist, + = interaction effects between stair condition and age group; $p < 0.05$, all significance levels reported at the significance level $p \leq 0.05$.

Further analyses were used to help understand how younger adults were able to use more of the longer going of Step2 during ascent, which then seemed to have a positive effect on the inconsistently shorter Step3. Older adults did not have an altered percentage contact length on Step2, which then led to a more risky position on Step3 with a reduced percentage foot contact length. To achieve this, foot positions relative to the lab coordinates were determined at toe-off from the walkway prior to stepping onto the stairs were compared by additional repeated measure ANOVAs. An interaction between condition and age group was detected ($p = .048$). Younger adult foot positions on the walkway were on average 8 mm closer to the staircase in the inconsistent condition compared to the consistent condition, whereas older adults were on average 14 mm further away. However, these differences were not detected as significant individually in

the post-hoc analyses (Figure 4.6). Additionally, horizontal stepping lengths from the walkway onto Step2 were not significantly different between conditions for either the younger ($p = .061$) or older group ($p = .822$). Horizontal stepping lengths from Step1 onto Step3 were also not different between conditions for the younger ($p = .084$) or older adults ($p = .248$).

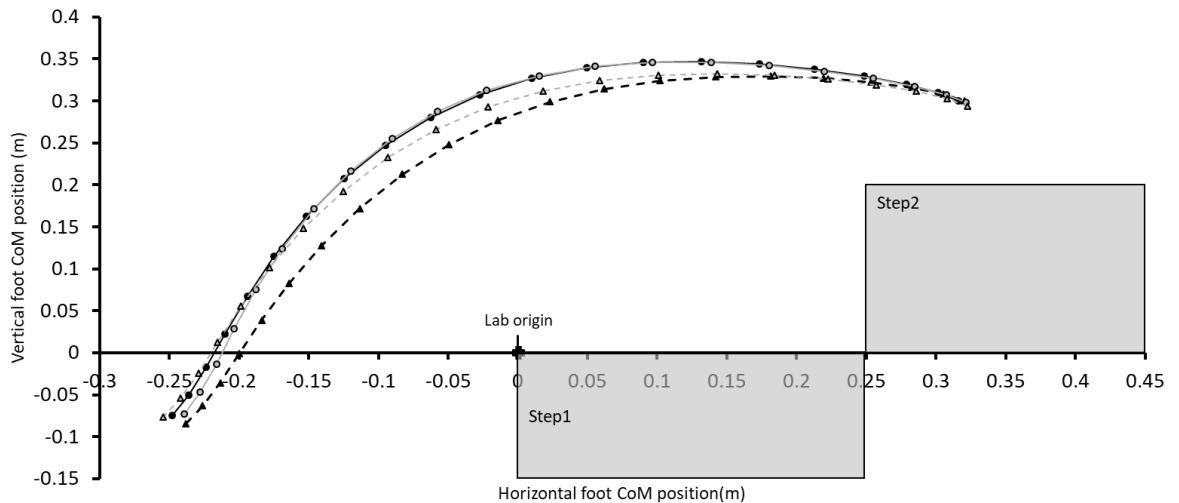

Figure 4.6. Stair ascent horizontal and vertical trajectory of the foot CoM. Data are time normalised from toe off from the walkway until one frame before contact on Step2, data points are sampled at every 5% of swing. —●— = younger adults (YA) consistent condition, —○— = younger adults inconsistent going, —▲— = older adults (OA) consistent condition, —△— = older adults inconsistent going. There were no significant differences detected with SPM analysis.

4.6 Discussion

This study is the first to document the effects of inconsistent goings on stair stepping parameters associated with fall risk. In descent, the behaviour of younger adults over Step2 edge (longer going) after the inconsistently shorter step (Step3), may increase the risk of a heel catch and a trip. In contrast to previous expectations, it seems that regardless of age, participants were able to adjust their stepping biomechanics late in the swing phase before making contact with the inconsistently shorter step (Step3). This was shown in the trajectory of the foot CoM position (Figure 4.3). In ascent, the stepping behaviour of older adults may increase the risk of them under-stepping on the inconsistently shorter step (Step3), possibly because they did not adjust to the

inconsistency in advance of stepping on it, whereas younger adults may have been more aware of the inconsistency perhaps visually detecting the change.

4.6.1 Stair descent.

Previous work hypothesised that the increased fall risk would occur on the step with an inconsistently shorter going, because it was assumed that the inconsistency would not be noticed in advance and therefore over-stepping would occur more frequently (Roys, 2013; Roys & Wright, 2005; Wright & Roys, 2005). The findings of this study do not support these hypotheses. In contrast, the stepping behaviour did change between stair configurations and therefore foot contact length did not significantly differ on the shorter going step for either group. This change in behaviour was evidenced in the first descent trial of the stairs with inconsistent goings, where both the younger and older groups moved their foot CoM further backwards in space (Figure 4.3) to place it with a similar percentage contact length on the inconsistently shorter step (Step3, Figure 4.2). It appears participants did detect the inconsistent shorter going and corrected their stepping behaviour. Consequently, the first part of Hypothesis 1 is not supported. However, this may have been subconscious because participants were not able to correctly identify the inconsistency after descent, this might reflect the complex effect that an inconsistent going has on stair stepping biomechanics.

The SPM analysis showed that foot CoM trajectories were significantly different only in the last quarter of the swing phase (78-100% of swing, Figure 4.3). This adjustment is extremely late in swing on the approach to the inconsistent step. Any deficits to the neurological or muscular systems may hinder a safe response and may result in an over-stepping situation such as that presented in Chapter 3, which could also result in a fall.

Following contact on the inconsistent shorter going step (Step3), participants then had to negotiate a longer going (Step2). Analysis of the foot CoM trajectory during swing from the inconsistent Step3 to Step1 indicates that older adults more tightly controlled their movement to maintain foot clearances that were not different over the longer Step2 (Figure 4.4), whereas younger adults seemed to exhibit movements that were less

cautious compared to the consistent condition, resulting in a more compromised foot clearance. The combination of a shorter and then a longer going on stairs has not been considered as a risk factor previously but should be included in future fall predictions.

4.6.2 Stair ascent.

Previously, an inconsistent going has mainly been considered a risk factor for descent (Roys, 2001, 2013). This study has shown that there is a reduced percentage foot contact length experienced by older adults during ascent on the shorter inconsistent step, which could increase the risk for a fall for them. Younger adults' stepping behaviour leading up to the inconsistently shorter step seemed to negate the under-stepping risk for them. It appears younger adults may have visually detected the inconsistent going early in their approach, because their final step on the walkway (last step before making a transition onto the stairs) was positioned closer to the stairs than in the consistent condition. By beginning in a more forwards position in space, younger adults then stepped further into the longer step (Step2) and were more able to maintain contact length on the inconsistently shorter step (Step3), without changing their typical stepping length on the stairs.

Older adults, however, were positioned further away from the stairs in their final step on the walkway before transitioning onto the stairs during the inconsistent condition. Consequently, percentage foot contact length was not significantly different to the consistent condition on the longer step (Step2) and was shorter on the inconsistently shorter step (Step3). Hypothesis 2 is therefore supported for the older adults, but not for the younger adults. The early detection of inconsistent going length and movements made prior to stepping on the shorter step appears to be important for maintaining stair safety.

In addition to increasing the chances of a slip with a decreased foot contact length, under-stepping may increase the moment arm distance between CoP and consequently could increase the plantar flexor muscular forces required to continue up the stairs. This did not appear to be a problem for the current group of older adults, but could become an issue on stairs with narrower goings where foot contact is already reduced (Di Giulio,

Reeves, et al., 2020) or for frailer older adults who are closer to their maximal strength capacity (Reeves et al., 2009), inappropriate foot placement may compromise whole body CoM control during the pull-up phase in stair ascent and could result in a fall.

4.6.3 Implications.

The results from this chapter indicate that, when exposed to inconsistencies in going dimensions, changes in stepping behaviour occurred in ascent for the younger adults and in descent for the younger and older adults. This does not support the previous assumptions and means that the previous predictions of fall risk on stairs may not be valid for healthy younger and older adults. Further investigation is required to determine if and how an inconsistent going leads to increased fall rates. This chapter provides data on one scenario that could help improve the predictability of such falls in the future. Stair research must first explore which magnitude of variability in dimensions becomes dangerous on stairs and determine whether those magnitudes alter depending on the size of the consistent dimensions, assessing visual behaviours as well as stepping mechanics would help to answer these questions. It is also vital to understand how frailer individuals might respond to the same inconsistencies.

At present only the first trial of the inconsistent going condition was analysed, more analysis would be needed to confirm that these stepping characteristics do not change in the subsequent four trials, it is suspected that individuals will continue to adapt to the inconsistent going condition with a similar stepping strategy. More research is also needed to determine the longer-term effects of stepping on stairs with inconsistently shorter goings. This will help determine the true level of risk that these impose towards stairs falls.

For the types of stepping behaviours that were observed it is speculated that participants must have visually but subconsciously detected differences in dimensions and determined the need to change stepping behaviour from that used in the consistent condition. It was expected that, the participants may have had good locomotory adaptability and therefore were able to control their CoM throughout the changes

because they were somewhat prepared. This will be discussed in more detail in the next chapter.

Despite the changes in foot trajectory made in descent, only one person, who had larger feet than the other participants (but not the largest), could correctly identify the specific inconsistency when verbally prompted. Perhaps this person was conscious of the going inconsistency as a greater proportion of his foot would overhang compared to some other participants, potentially putting him closer to his critical threshold where he may have slipped, it is suspected that he may have had to make some other alterations to his stepping mechanics to stay safe on the inconsistently shorter step, as on average the participant did not step with more than 30% overhang on any step in any descending condition. Other participants including the other males with large feet could not verbalise the correct dimension changes. Regrettably, younger adults were not directly asked if they could detect changes in stepping dimensions. However, averaged foot lengths (calculated from absolute and percentage foot contact length data) were not significantly different between younger ($280 \text{ mm} \pm 21 \text{ mm}$) and older adults ($273 \text{ mm} \pm 21 \text{ mm}$, $p = .213$) and the spread of foot lengths were normally distributed.

In normal circumstances in the home, the risk of slipping could be increased when an inconsistent shorter going exists (Templer, 1992). For example, people may not pay as much attention to familiar stairs and are and more likely to be dual tasking and or distracted which could impair performance (Di Giulio, McFadyen, et al., 2020; Vallabhajosula, Tan, Mukherjee, Davidson, & Stergiou, 2015). Due to the timing of the change to foot trajectory, visual detection and interpretation seems crucial to correct foot placement (Miyasike-Dasilva et al., 2011; Startzell et al., 2000; Timmis et al., 2009), consequently attention to the stairs (Zietz & Hollands, 2009), good illumination (Hamel, Okita, Bus, et al., 2005; Thomas et al., 2020) and being able to clearly detect the step-edges (Foster et al., 2014) seems imperative to maintaining safe stepping mechanics on stairs with inconsistent goings. These factors should be considered in future research.

There were some general limitations within this thesis that affect this study, which are included in the general discussion. One limitation specific to this chapter was that participants often scuffed their heel and/or knocked heel markers off on the riser of Step4, due to the shorter going of Step3 during the inconsistent condition. This may have altered the stepping trajectory from Step3 over Step2 to Step1. Additionally, it cannot be excluded that the altered stepping behaviours seen in descent were due to their prior experience of that step in the immediately preceding ascent.

4.7 Conclusion

When negotiating stairs with an inconsistently shorter going participants were able to alter their stepping biomechanics during descent which permitted an approximately normal foot placement. However, this adjustment occurred late in swing which likely presents biomechanical challenges and risks in itself. Older adults were either not able to adapt their strategy in time during ascent or did not “chose” to which could represent an increased slip risk. These findings do not support previous hypotheses on predictions of falls on inconsistent stairs and prompt more biomechanical research into stepping mechanics and fall risk, so that policy, regulations and building practices can be updated accordingly. Future research should consider the effects of different presentations and magnitudes of the shorter/longer step combination, as well as how initial starting positions and visual processing may influence stepping mechanics over/on inconsistent steps. Only then can the true level of fall risk be determined on stairs with inconsistent goings.

Chapter 5:

The Impact of Inconsistent Step Dimensions on Whole-Body (CoM) Control During Stair Descent.

5.1 Introduction

The previous experimental chapters have studied the stepping behaviour as participants negotiate the inconsistent stairs. This provided an understanding of how inconsistencies in step dimensions alter the shoe-step interaction and may lead to falls by slips and trips. However, a fall can also occur from a loss of dynamic control of the CoM (Bosse et al., 2012; Roys, 2001; Templer, 1992; Winter, 1995). In both conditions when the participants contacted the inconsistent and subsequent steps with altered foot-step interactions there will likely be a consequence for how effectively the CoM is controlled at this time. A loss of control of the CoM will ultimately determine whether the perturbation would result in a fall or not.

It has previously been reported that CoM control during gait is highly regulated (Winter, 1995), but stair descent is inherently more dangerous as step dimensions constrain the available horizontal limits of the base of support and centre of pressure (CoP) needed for safe descent (Mian et al., 2007). When inconsistencies exist, the control could be compromised if the available limits for the CoP are further constrained by reduced step going or foot contact length. Additionally, balance may be perturbed if the CoM motion is not well controlled. CoM vertical velocities at the time of each foot contact during stair descent, have indicated the amount of control individuals have during the preceding swing before contact (Buckley et al., 2013; Gosine et al., 2019; Mian et al., 2007). Increased velocities have been proposed to be evidence of lack of control (Buckley et al., 2013) and a less cautious strategy (Ackermans et al., 2019). Older adults tend to show reduced CoM velocities and reduced accelerations throughout stair descent compared to younger adults (Buckley et al., 2013), but have a lower ability to control CoM velocities and accelerations when task demand increases, e.g., greater rise heights (Foster et al., 2019).

CoM control in descent is also dependent on the frictional properties of the shoe and the stair. Peak required coefficient of friction, which occurs just after initial contact and just prior to toe-off, indicates the minimum coefficient that must be available to

prevent a slip. It is determined by the ratio between vertical and horizontal ground reaction forces and as such is dependent on stair biomechanics (Hamel, Okita, Bus, et al., 2005). In some trials of Hamel et al.'s study (2005), some younger and older adults had a required coefficient of friction which was greater than the recommended cut-off for stairs of 0.5, documented in building regulations (NFPA 101, 2000). This could accelerate the CoM out of the base of support (Roys, 2001; Templer, 1992), causing a slip which could result in a fall. It is not documented in the literature what happens to CoM control when a step dimension inconsistency is encountered. For this reason, parameters that could disturb CoM control for younger and older adults were considered in this experimental chapter.

During descent of stairs with inconsistent rise heights, as presented in Chapter 3, younger and older adults did not adjust their stepping behaviour prior to contacting the inconsistent steps. Therefore, participants contacted these steps at an unexpected point in space and time compared to the consistent condition. When stepping down over a smaller rise (onto Step3), contact was earlier than expected, while participants "fell" for longer when stepping down the larger rise (onto Step2) later than would have been expected. Both of these will pose additional challenges to CoM control at initial contact and during the loading and forward continuation phases by changing the kinetic demands, potentially compromising the muscles' readiness for loading with pre-activation (Hortobágyi & Devita, 2000), altering the base of support available under the foot contact length (Mian et al., 2007), reducing distances between the CoP and step-edge, while simultaneously increasing the CoM and CoP separation (distance) and/ or changing the amount of time participants must control the lowering or maintain single limb support, all of which creates greater instability (McFadyen & Winter, 1988).

Unlike with the inconsistent rise (Chapter 3), when exposed to an inconsistent going (Chapter 4), both the younger and older adults made changes to their stepping pattern in descent prior to contacting the inconsistently shorter going (Step3). However, this correction in foot trajectory occurred late during swing. For this change to happen, alterations to CoM control must also have occurred late in swing. If an accompanying

correction in CoM control, such as CoM acceleration, is not made then the CoM could be further forward at initial contact, altering the postural response and muscle forces required to control the loading, this could increase the risk of a fall in the forwards direction due to the CoM being further outside of the base of support (Templer, 1992).

The aim of the experiments described in this chapter were two-fold. Firstly, we sought to establish how CoM control was changed in descent as a result of unexpectedly stepping onto an inconsistently smaller rise followed by a larger rise. The second aim was to establish the changes made to CoM control in advance of stepping onto an inconsistently shorter going and how that enabled continued CoM control thereafter. It was Hypothesised that:

5.2 Hypothesis 1

In descent of the inconsistent rise stairs, CoM control will be changed compared to descent of consistent stairs, because of the participants' failure to adjust stepping mechanics prior to making contact with the step with greater rise. Specifically, these changes will include:

(i) Increases in loading forces, CoM-CoP separation and decreases in CoP to step-edge distances, at initial contact and during the loading phase onto the inconsistently higher rise step (Step3) which could compromise CoM control.

(ii) Greater loading forces and decreases in CoM-CoP separation could also compromise CoM control during the controlled lowering to the next step with the longer inconsistent rise during the following initial contact and during the loading phase (Step2). Increased distance between CoP to step-edge distance might help off-set the challenges to CoM control.

5.3 Hypothesis 2

In descent of the inconsistent going stairs, adaptations made to stepping movement in late swing prior to contacting the inconsistently shorter going step, will cause an increase in CoM acceleration at that time, but will result in CoM control that is

not different to the consistent condition during initial contact and the loading phase on the shorter going step (Step3).

5.4 Methods

The data reported in this chapter were obtained in the same experiments detailed in the General Methodology (Chapter 2). The filtered kinetic and kinematic data at instants or in phases of the gait cycle which were hypothesised to alter dynamic control of the CoM were created in Visual 3D (version 6.01.043 Visual3D, C-Motion, Germantown, USA) and then exported into SPSS (version V26, IBM SPSS Statistics, IBM Corp, Armonk, NY, USA) for instantaneous analysis and MATLAB for SPM (Pataky, 2012) analysis for data curves time normalised to 100% of stance on Step4, Step3 and Step2.

5.4.1 Selection of outcome measures.

In descent of the inconsistent rise stairs the phases of interest were the swing and stance phases over the inconsistent steps and so data were extracted from the instant before contact on Step3 until toe-off on Step2. Temporal outcome measures were stance time and the amount of time (absolute and relative to stance phase) spent in single limb support. The CoM motion at the end of controlled lowering was assessed by the instantaneous vertical CoM velocity one frame before contact on Step3 and Step2. One frame before contact was used to limit the effects of hitting the step surface in different positions. The subsequent loading on both steps were assessed from vertical loading rates and vertical and anterior posterior ground reaction forces (GRF). Risk of a slip during weight acceptance was quantified by the peak required coefficient of friction during the loading phase. Outcome measures reflecting dynamic control of the CoM were: the horizontal distance between the centre of pressure (CoP) and step-edge, which indicates the anterior base of support (Novak et al., 2016), the horizontal distance between CoM and CoP throughout stance on Step3 and Step2, which indicates stability or potential instability (King et al., 2018; Mian et al., 2007) and horizontal and vertical CoM accelerations throughout stance on Step4 Step3 and Step2 were compared to indicate overall control on each step.

In descent of the inconsistent going stairs the phase of interest was from swing on the approach to Step3 (toe off Step5) and during stance (until toe-off) on Step2. Temporal characteristics, controlled lowering, loading and CoM control on these steps were assessed by the same outcome measures listed above. In addition, to quantify if/how CoM control was impacted by the late adjustment in foot position on the approach to Step4, the CoM vertical and anterior-posterior accelerations during stance on Step4 and the horizontal distance between the CoP and step-edge and the distance between the CoM and CoP on Step3 were additionally analysed.

5.4.2 Definition and calculation of outcome measures.

Stance time and single-limb and double support phases were defined from when vertical ground reaction forces (GRF) became less than 20 N for toe-off events and became greater than 20 N for initial contact events. Toe-off Step5 was determined at kinematic events created by algorithms on steps where force data was available.

Instantaneous vertical CoM velocity was calculated as the first derivative of CoM position one frame before contact with on Step3 and Step2, where contact was defined as 20 N of force.

Vertical loading rate was determined between 10% - 90% of the first vertical force peak (loading phase) which was normalised to body mass (Christina & Cavanagh, 2002).

Vertical and anterior-posterior GRFs were normalised to body mass and to 100% of stance on Step3 and Step2.

Required coefficients of friction were determined as the sum of anterior-posterior forces and medio-lateral forces divided by the vertical forces throughout stance (Christina & Cavanagh, 2002). The peak required coefficient of friction during the loading phase (McFadyen & Winter, 1988) was extracted only on Step3, as reduced foot contact length described in Chapter 3 could increase the risk of slip at this time point (Roys, 2013).

Horizontal distance between CoP and step-edge was calculated throughout stance and was defined as the difference between the anterior-posterior CoP position defined by the force plate and the anterior-posterior step-edge position for each of Step3 and Step2.

Horizontal distance between CoM and CoP throughout stance was calculated as the difference between the anterior/posterior position of the CoM and the CoP (Reeves et al., 2009). In descent a negative value indicates that the CoM was posterior to the CoP.

Acceleration of CoM in the vertical and anterior-posterior directions were calculated as the second derivative of CoM position.

5.4.3 Statistical analysis.

Singular value variables such as CoM velocity, loading rate and coefficient of friction were tested in SPSS with a mixed model two-way repeated measures analysis of variance (ANOVA), post hocs were used when significances were found. Comparisons were determined, within each condition (consistent versus inconsistent rise stairs or consistent versus inconsistent going) and between the two age groups (younger versus older adults) with an alpha level set to $p \leq .05$ at the univariate level (younger $N = 25$, older $N = 32$). Data curves were exported into MATLAB for SPM 1-dimensional curve analysis (Pataky, 2012), alpha level was also set to $p \leq .05$, curve comparisons were made between 25 younger and 25 older adults.

5.5 Results

5.5.1 Inconsistent rise: temporal effects.

In the consistent condition, the amount of time spent in stance was ~ 0.67 s on Step4 (Figure 5.1 Part A), Step3 (Figure 5.1 Part B) and Step2 (Figure 5.1 Part C) for both the younger and older adults and was not significantly different in the inconsistent rise condition on Step4 or Step3. However, Step2 stance time was significantly reduced by approximately 0.02 s for the younger adults and by 0.01 s for the older adults ($p = .018$, Figure 5.1 Part C). In the consistent condition, on average between the three steps,

younger adults spent $0.39 \text{ s} \pm 0.04 \text{ s}$ (57.3%) of stance in single-limb support and the older adults spent $0.40 \text{ s} \pm 0.06 \text{ s}$ (60.5%) of stance in single-limb support.

During the inconsistent rise condition, the duration of single-limb support was significantly reduced on Step4 ($\Delta = 0.01 \text{ s}$, $p < .001$) as double support occurred 1.5% of stance sooner in the rise condition. This was caused by stepping a smaller distance down before initial contact on Step3 (Figure 5.1 Part A). During stance on Step3 (Figure 5.1 Part B), single-limb support began significantly later ($p < .001$) for the younger adults (0.013 s) and older adults (0.005 s) and lasted significantly longer, for the younger (0.004 s) and older adults (0.009 s, $p < .001$). Next in the inconsistent rise condition participants had to step down further to reach the surface of Step2. Although single limb support commenced significantly sooner on Step2 ($\Delta \approx 0.01 \text{ s}$ $p < .001$), single-limb support did not last any longer. In brief, the length of time spent single-limb support reduced on Step4, increased on Step3 and was not different on Step2 when exposed to the inconsistent rise condition.

5.5.2 Inconsistent rise: biomechanical effects on Step3.

After stepping down the smaller rise, negative vertical velocities at the instant before contact on Step3 were significantly reduced (main effect: $p = .013$), however, post-hoc tests revealed that this change was only significant for the older adults ($p = .001$) (Figure 5.2 Part A). As a result, the following loading rates (Figure 5.2 Part B) and vertical forces on Step3 (Figure 5.3 Part A) were also reduced. There was an interaction effect for mean vertical loading rates ($p = .040$), whereby loading rates of the first vertical force peak decreased more for the older ($\Delta = -1.3 \text{ m.s}^{-1} \cdot \text{kg}$) than younger ($\Delta = -0.29 \text{ kg.m.s}^{-1}$) adults (Figure 5.2 Part B and Figure 5.3 Part A for visualisation). Post hoc tests revealed that only the older adults had a significant reduction in loading rate ($p = .001$).

Vertical forces were significantly reduced around peak loading force, which coincided with the initiation of single-limb support (14.1-26.1% of stance; $p = .001$) for the younger ($\Delta \approx -0.07 \text{ N.kg}^{-1}$) and older adults ($\Delta \approx -0.12 \text{ N.kg}^{-1}$) (Figure 5.3 Part A). At initial contact with Step3, posteriorly directed forces were increased $\Delta \approx 0.02 \text{ N.kg}^{-1}$ during loading (16.5-22.2% of stance; $p = .020$) and were then significantly lower during single

limb support (32.0 – 35.0% of stance; $p = .034$) (Figure 5.3 Part B.). Reduced vertical forces combined with increased posterior force increased the peak required coefficient of friction ($\Delta \approx 0.02$) during the loading phase ($p = .003$) (Figure 5.2 Part C). Post-hocs revealed that the change in required coefficient of friction was only significant for the older adults ($p = .005$).

From initial contact with Step3 until early single-limb support (0 - 23.4% of stance) the CoM was ~ 1 cm more posterior to the CoP compared to the consistent condition ($p = .001$, Figure 5.3 Part D). Even though the foot was positioned further forward on the step at initial contact (Chapter 3, Figure 3.4 Part B) the distance from the CoP to the step-edge was not significantly different in the first 25% of stance (Figure 5.3 Part C). During midstance (33.4 – 69.6% of stance) the horizontal distance between CoP and step-edge was greater ($p < .001$) for both the younger and older adults. For a shorter duration of midstance (only between 54.5-58.0% of stance), CoM was slightly more anterior to the CoP ($p = .044$) (Figure 5.3 Part D).

5.5.3 Inconsistent rise: biomechanical effects on Step2.

Following the longer step down, vertical CoM velocity immediately prior to contact with Step2 (larger rise) was not significantly different between the two staircase conditions (Figure 5.4 Part A). However, vertical loading rates were significantly increased for both groups when exposed to the inconsistent larger rise down onto Step2 compared to the consistent condition ($p < .001$) (Figure 5.4 Part B). Vertical forces were not significantly different between the two conditions (Figure 5.4 Part C). An interaction effect was found at initial contact for the posterior forces (Figure, 6.4 Part D), whereby the posterior forces were significantly increased ($p = .048$), $\Delta \approx < 0.006 \text{ N.kg}^{-1}$ in magnitude for both the younger and the older adults. A main effect of condition was then found before initiation of single-limb support (10-19% of stance), whereby posterior forces were reduced by $\Delta \approx 0.015 \text{ N.kg}^{-1}$ ($p = .006$) (Figure 5.4 Part D).

The horizontal distance between CoP and step-edge of Step2 was increased for both groups ($\Delta \approx 10 \text{ mm}$, $p = .002$) at initial contact and before initiation of single-limb

support (0-19% of stance) (Figure 5.4 Part E). There was $\Delta \approx 15$ mm less horizontal distance ($p < .001$) between CoM and CoP on Step2 from initial contact to early single-limb support (0-24.1% of stance) (Figure 5.4 Part F). Additionally, at initial contact until 7.5% of stance, vertical CoM accelerations were increased by $\Delta \approx 0.27 \text{ m}\cdot\text{s}^{-2}$ for both groups ($p = .016$) and were compensated prior to single-limb support, with a greater upward vertical CoM acceleration between 13.7- 19.5% $\Delta \approx 0.5 \text{ m}\cdot\text{s}^{-2}$.

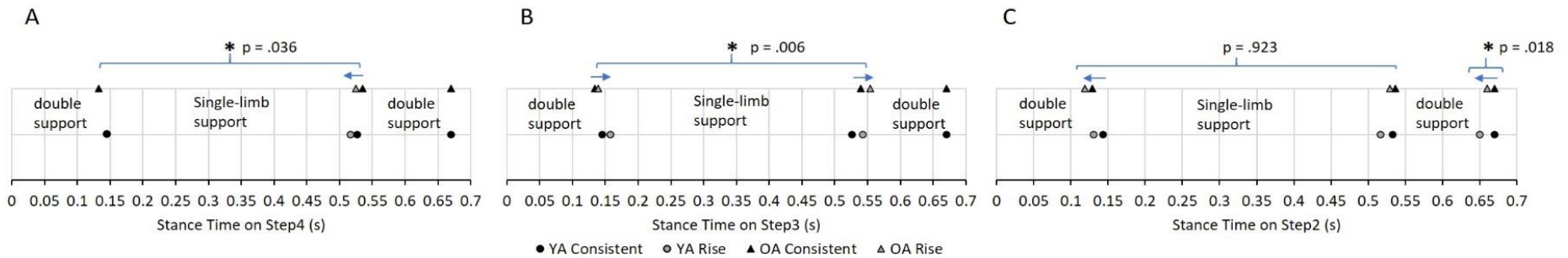

Figure 5.1. Stance time and single-limb support duration on A) Step4, B) Step3 and C) Step2 for the younger (YA) and older adults (OA) in the consistent and rise conditions. * indicates a condition effect between stairs, for single limb support and reduced stance time, → indicates direction and condition effect for gait event timings, $p < .05$. Note: stance time was ~ 0.67 s for all steps in the consistent condition and was only significantly reduced in the inconsistent rise condition on Step2 (part C) by 0.02 s for the younger adults and 0.01 s for the older adults.

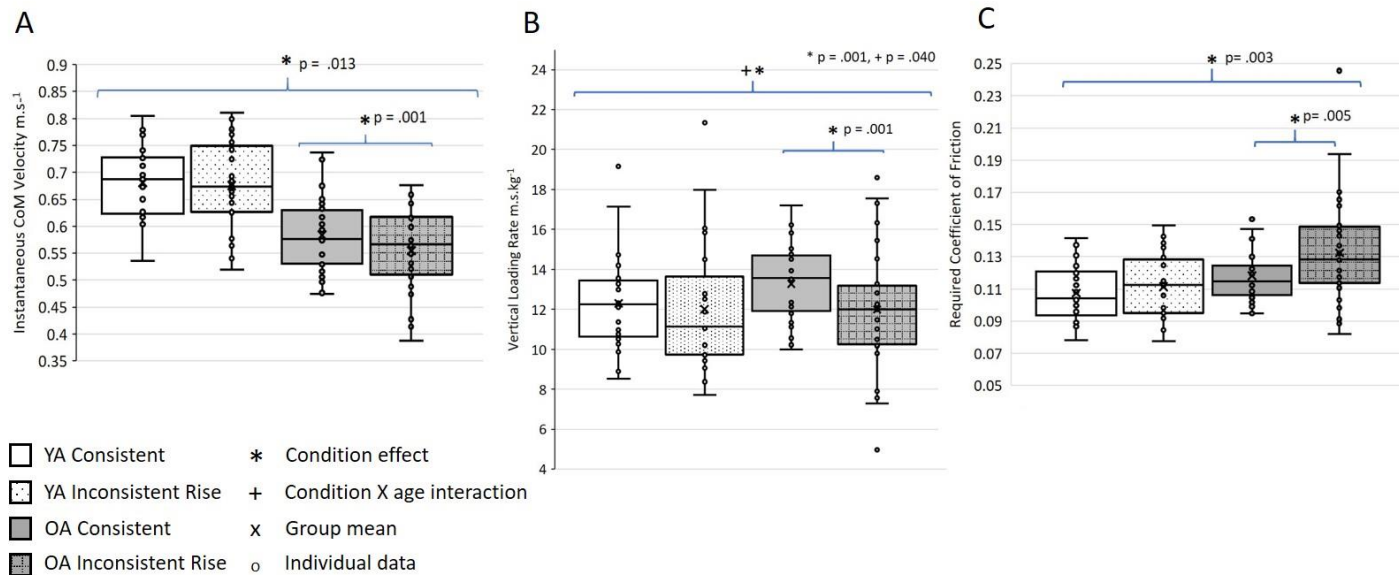

Figure 5.2. Step3 instantaneous data including: A) downward centre of mass (CoM) velocity 1 frame before contact on Step3, B) Vertical loading rate relative to body mass on Step3, calculated between 10-90% of the first vertical ground reaction force peak C) Peak required coefficient friction in the loading phase on Step3. * Condition effect $p < .05$, + condition by age interaction $p < .05$.

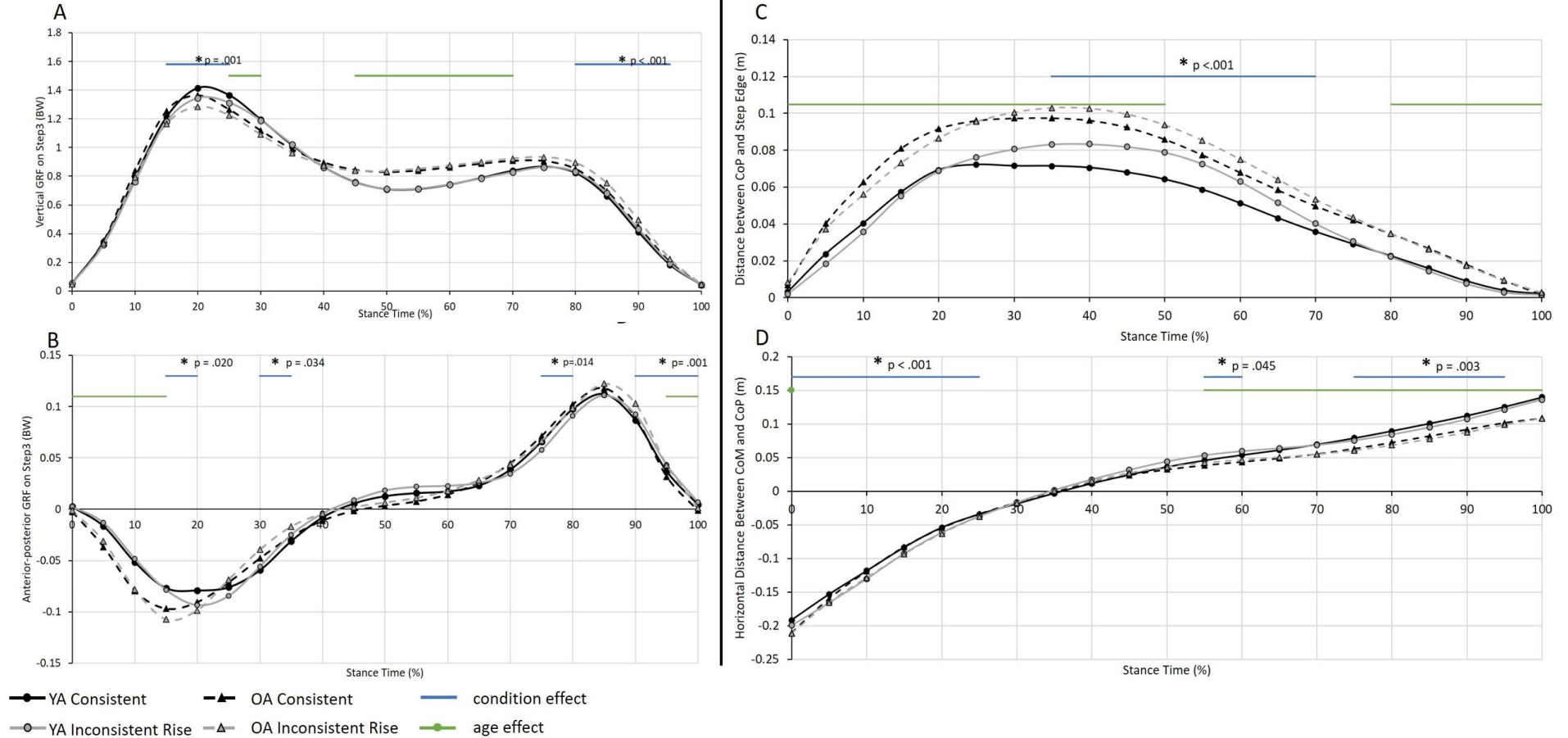

Figure 5.3. Step3 data curves normalised to 100% of stance on Step3 including: A) Vertical ground reaction forces (GRF) normalised to bodyweight (BW), B) Anterior-posterior GRF normalised to BW (anterior forces are positive), C) horizontal distance between centre of pressure (CoP) and Step3 edge, D) horizontal distance between whole body centre of mass (CoM) position. Data are sampled at 5% increments and significant condition effects are indicated to the nearest 5% (blue line) with an individualised p values within the figure. Age effects with $p < 0.05$ are presented with a green line and do not have individualised p values within the figure.

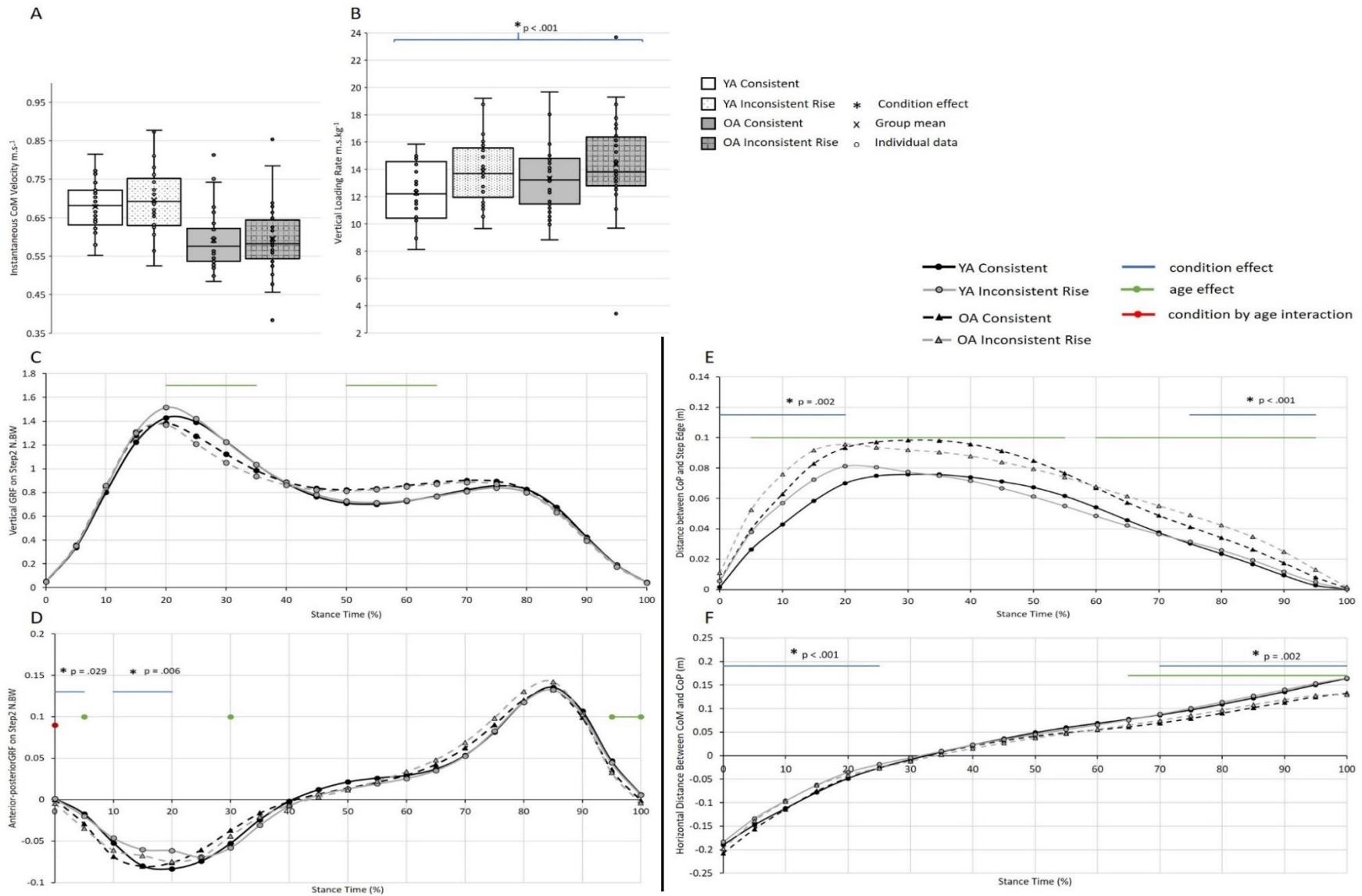

Figure 5.4. Step2 data including instantaneous data A-B and Data curves normalised to 100% of stance on Step2 C-F. A) Instantaneous downward centre of mass (CoM) velocity 1 frame before contact on Step2, B) Vertical loading rate relative to body mass on Step2, calculated between 10-90% of the first vertical ground reaction force peak. Data curves were sampled at 5% increments and included C) Vertical ground reaction forces (GRF) normalised to bodyweight (BW), B) Vertical ground reaction forces (GRF) normalised to bodyweight (BW), C) Anterior-posterior GRF normalised to BW (anterior forces are positive), D) horizontal distance between centre of pressure (CoP) and Step3 edge. E) horizontal distance between whole body centre of mass (CoM) position. Significant condition effects are indicated to the nearest 5% (blue line) with an individualised p values within the figure. Age effects with $p < 0.05$ are presented with a green line and do not have individualised p values within the figure. An interaction effect was only found at initial contact in part D.

5.5.4 Inconsistent going: temporal effects

Significant condition by age interactions existed for stance time on Step4 ($p = .003$) Step3 ($p = .011$) and Step2 ($p = .031$). For the younger adults, stance time reduced by $\Delta \approx 0.02$ s to 0.65 s instead of 0.67 s on each step. For the older adults, stance time increased from 0.67 s to 0.70 s ($\Delta \approx 0.03$ s). Accordingly, no main condition or age effects were detected for stance time. Interaction effects were also found for time spent in single-limb support on Step4 ($p = .005$) and Step3 ($p = .017$), Whereby single-limb support time reduced for the younger adults on both steps ($\Delta \approx 0.01$ s) but increased for the older adults on Step4 by $\Delta \approx 0.03$ s and on Step3 by $\Delta \approx 0.02$ s. Despite the differences in gait events there were minimal differences detected throughout the navigation over a shorter going of Step3 and a longer going of Step2.

5.5.5 Inconsistent going: biomechanical effects of altering foot trajectory prior to contact.

During stance on Step4, when the contralateral limb was in swing towards the inconsistent shorter going (Step3), there were interaction effects detected during single-limb support (23.6% - 31.9% of stance) for the vertical CoM accelerations ($p = .008$), which were increased for younger adults but reduced for older adults (Figure 5.5 Part A). However, there were no condition effects or interactions detected in the anterior-posterior CoM accelerations. There was another interaction detected prior to initiation of double support (73.4% - 77.0% of stance, $p = .035$), where older adults had a less negative vertical accelerations and younger adults had a more negative vertical accelerations (Figure 5.5 Part A).

At initial contact on Step3 (0-6% of stance) there was a significantly reduced distance between the CoM and CoP in the inconsistent going compared to the consistent condition ($\Delta \approx 12$ mm for younger and $\Delta \approx 7$ mm for older adults, $p = .035$, Figure 5.5 Part B). Despite, the not significantly different foot placement in the inconsistent going condition at initial contact (Chapter 4, Figure 4.2) horizontal distance between CoP and step-edge was significantly reduced for both groups at three time points during stance on Step3 (Figure 5.5 Part C) between: 6.2% - 8.2% ($p = .048$), 17.6% - 28.0% ($p = .018$) and

61.5% - 74.4%. After single-limb support was initiated the younger adults had reduced distance $\Delta \approx 9$ mm and older adults $\Delta \approx 7$ mm. No main condition or interaction effects were detected for CoM vertical velocity, vertical GRF, anterior-posterior CoM acceleration. Anterior posterior GRF only became significantly more anterior ($p = .014$) in the late stance on Step3 (93.0 – 100% of stance).

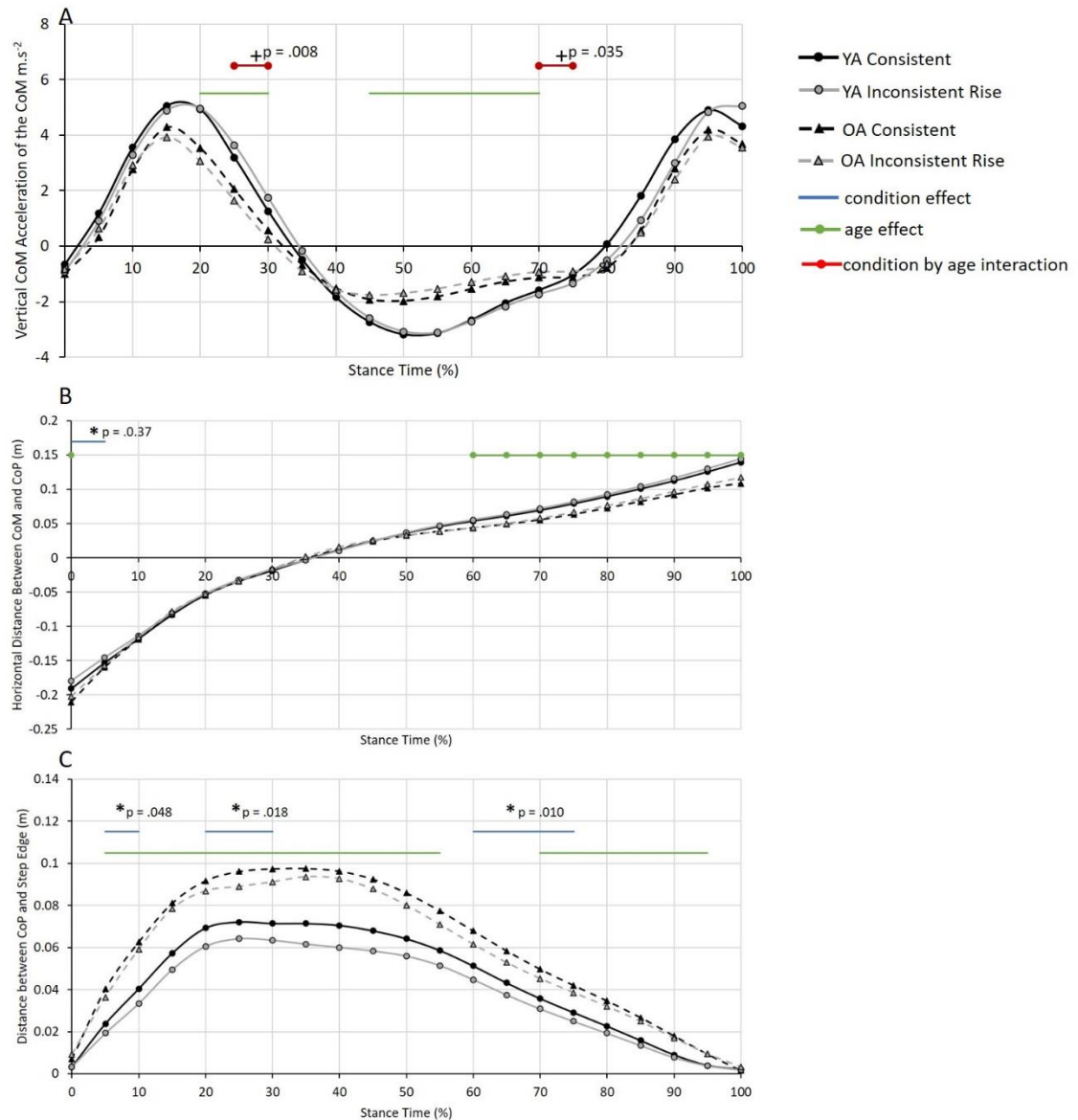

Figure 5.5. Inconsistent going condition compared to consistent condition for younger (YA) and older adults (OA). Data curves were sampled at 5% increments and included A) vertical CoM acceleration during stance on Step4, B) horizontal distance between CoM and CoP position on Step3, C) horizontal distance between CoP and Step3 edge. Significant condition effects are indicated to the nearest 5% (blue lines) with an individualised p values within the figure and Interaction effects (red lines) were present in the vertical CoM acceleration. Age effects with $p < 0.05$ are represented with a green line and do not have individualised p values within the figure.

5.6 Discussion

This experimental chapter firstly aimed to document how CoM control was changed during descent as a result of negotiating an inconsistent smaller rise followed by a larger rise and secondly, how CoM control was changed in advance of negotiating an inconsistently shorter going followed by a longer going and how CoM control was maintained after contact.

5.6.1 Inconsistent smaller rise Step3.

In a group of healthy younger and older adults, stepping down on to Step3 (smaller rise) resulted in smaller CoM vertical velocities prior to contact (Figure 5.1 Part D), reduced vertical force loading rates (for the older adults, Figure 5.1 Part E) and reduced peak vertical forces at contact (Figure 5.2 Part A). These biomechanical characteristics might reduce the risk of a fall on Step3 compared to the consistent stepping condition. In terms of negative effects, time spent in single limb support was increased (Figure 5.1), however only by a small amount, which is unlikely to be functionally important. However, peak posterior forces were increased during the loading phase on Step3 (Figure 5.2 Part B) leading to greater required coefficients of friction at initial contact for the older adults (Figure 5.1 Part F). These were likely caused by the unexpected early contact that occurred on Step3, interrupting the posteriorly directed trajectory of the foot, putting the CoM more posterior to the CoP position at initial contact compared to the consistent condition. Because of this early and reduced foot contact length (Chapter 3), it could be hypothesised that the CoP to step-edge would have been smaller, however, this was not the case and was in fact larger than the consistent condition by mid-stance. This suggests an adjustment in body position which could help mitigate the risk of a slip off the inconsistent step.

This data suggests that individuals were responding to proprioceptive feedback from pressure sensors in the feet which enabled them to correct the location of the CoP relative to the step-edge and therefore creating a larger mechanical advantage (Novak et al., 2016) over which the CoM could be safely controlled. Despite this correction in CoP

position the CoM was also moved posteriorly which is thought to help redistribute the forces away from the ankle and allow individuals to stay within their maximal capacities (Reeves et al., 2009) over the inconsistency, making the individual somewhat safer. This could be a cautious response to the inconsistency and shows that safe CoM control after the perturbation on stairs is a combination of subtle but complex movements.

Therefore, after descending a 10 mm smaller rise, the changes in CoM control, including increases in posterior GRF, increased required coefficient of friction particularly for the older adults at initial contact and loading phase, indicate a less stable and less safe stair descent. By the first third of stance on Step3, CoM control was approximately back to normal and variables such as CoP to step-edge distance were even improved making the individual's movements safer. So even though participants contacted the step surface sooner than anticipated, the changes in CoM control that followed supported good balance control over the inconsistency. Therefore, these findings do not fully support Hypothesis 1(i).

Frailer individuals and people with peripheral neuropathies may not be able to sense the change in foot pressure as easily (Startzell et al., 2000), therefore might not be able to correct their CoP position as quickly. If those individuals or others who do not promptly adjust for the amount of overhang also have muscle weakness, incorrect foot positioning and/or inappropriate footwear the potential of a slip and fall will be increased especially during the loading phase, further work is needed to test this.

5.6.2 Inconsistent larger rise Step2.

The larger rise between Step3 and Step2 created a longer distance to drop down onto Step2, however, vertical CoM velocities prior to contact and vertical forces at initial contact were not significantly different, suggesting that, consistent with previous literature (Foster et al., 2019; Novak et al., 2016) individuals were able to control the downwards CoM motion during the greater descent.

Nonetheless, it appears something changed in the participants' readiness for loading, since greater posterior forces, greater vertical loading rates and downward CoM accelerations were evident on Step2. Upward CoM accelerations were then increased prior to the start of single-limb support and participants experienced a larger change in vertical CoM acceleration during the inconsistent larger rise condition. However, again these effects were quickly controlled prior to single limb support and forward progression.

The foot on Step2 had a greater contact length (Chapter 3) and was more posterior in space, meaning that the CoP was more posterior to the step-edge at initial contact and there was also a smaller separation between the CoM and CoP. As the CoM was controlled more through the loading phase the participants appeared to be safer in the inconsistent condition than they had been in the consistent condition. This also does not fully support Hypothesis1(ii), because it seems participants were able to change joint loading throughout descent of Step3 and Step2 to accommodate the changes needed to maintain CoM control when exposed to the smaller and then larger rise inconsistency. Frailer/distracted individuals may not be able to respond as quickly nor as efficiently to this size of inconsistency.

5.6.3 Inconsistent shorter going.

Before contacting the inconsistent shorter going (Step3), participants made a late change in the trajectory of the foot to maintain contact length similar to that on the consistent stairs (Chapter 4). The timing of this adjustment coincided with an increase in vertical CoM accelerations for the younger adults and decreases in vertical CoM accelerations for the older adults which may represent a different movement strategy between the groups (Reeves et al., 2008b, 2009) in dealing with the inconsistency. A reduced acceleration from the older adults may be a cautious approach, possibly ensuring that joint moments stay within maximal capacities, which could also account for the increased time spent in single-limb support. This seems to be a trade-off between something considered risky such as longer time spent in single limb support versus something safer such as reduced accelerations (Ackermans et al., 2019). Whereas, the

greater locomotor flexibility of younger adults allowed them to negotiate the inconsistency without this same controlling behaviour.

Since the foot was relatively further back in the global space, the separation between the CoM and CoP was slightly smaller in loading on Step3 and returned to normal as the CoM advanced forwards throughout stance. The reduced distance between CoP and step-edge suggests that the CoP was located further forward within the foot which could be more risky in terms of slip risk but further supports that joint moments were altered to stay within maximal capacities. Trunk flexion angle may have also increased to enable a better head position to visualise the upcoming steps. The significantly different anterior forces at the end of stance on Step3 may increase the risk of a slip during the unloading phase which may accelerate the CoM forwards onto the next step. All things considered there were no major changes to the CoM control after contact with the shorter going step, therefore supporting Hypothesis 2, as individuals were able to control their CoM after making the anticipatory adjustments while in contact with Step4.

5.6.4 Implications and future study of stair inconsistencies on balance control.

The present study indicates that during descent, a 10 mm inconsistent smaller rise or going there were some disturbances to the balance of older and younger adults. However, these changes were well controlled by our participants, by quickly and effectively reacting to the perturbation to regain stability prior to contacting the next step. Consequently, the present data indicate that it is unlikely that these participants will fall due to lack of CoM control for the scenarios presented in this thesis. The main mechanisms by which inconsistent stairs cause falls appears to be tripping or overstepping on the inconsistent steps (Nemire et al., 2016; Roys, 2001, 2013), which would lead to a greater perturbation to balance that could be more challenging to control, such as those reported for younger adults in an induced slipping scenario (Gosine et al., 2019).

This interpretation should only be applied to individuals similar to the participants, moving in environments similar, to this study. In other circumstances the detection and responses to inconsistencies may not be the same and should be investigated further. For

instance, frailer individuals may not have the same capacity to react as quickly or keep the CoM under the same control (Zietz et al., 2011). The alterations in CoM control observed in this thesis, were likely driven by proprioceptive feedback from the foot, ankle and body positions, this could become a problem for individuals with peripheral neuropathy (King, Vanicek, & O'Brien, 2017) caused by ageing and or diabetes to name a few. Situations such as poor lighting would reduce the ability to define step-edges clearly and may impact on confidence and stepping mechanics of older adults (Thomas et al., 2020; Zietz et al., 2011).

Additionally, individuals with poor vision such as macular degeneration (Startzell et al., 2000) or those who are carrying objects, dual-tasking and have become distracted while negotiating stairs (Hashish, Toney-bolger, Sharpe, Lester, & Mulliken, 2017; Ojha, Kern, Lin, & Winstein, 2009; Templer, 1992; Templer et al., 1978) may fail to see the inconsistency and then may also fail to adjust their stepping mechanics appropriately, which may lead to greater variability in stepping movement, reduced clearances, greater overstepping and poor body positioning and could therefore increase the chances of an incident causing a serious fall. Not seeing the inconsistency could be a risk for all individuals.

It is well documented in the literature that, older individuals have reduced muscle strength (Pijnappels, Reeves, et al., 2008; Reeves et al., 2008b) and tendon stiffness (Karamanidis & Arampatzis, 2007; Spanjaard, Reeves, Van Dieën, Baltzopoulos, & Maganaris, 2007). In combination, these changes would limit the ability to generate opposing muscle torques quickly, therefore older and frailer individuals are less likely to recover balance if a fall does occur and are more likely to have the most severe falls, with the longest time spent in hospital (Jacobs, 2016). Considering the frequency of inconsistencies that exist in homes and public stairs and their association with serious injury (J. Cohen et al., 2009; Roys, 2001, 2013), more research needs to be undertaken to investigate the impact of inconsistencies to human balance control during stair negotiation, so that appropriate fall prevention interventions can be implemented in the future.

5.7 Conclusion

The 10 mm inconsistencies experienced in this study caused relatively small alterations to balance control for healthy younger and older adults. In descent, experiencing a smaller rise first, required safe-guarding adjustments to be made after contact with the step which prevented the CoM and CoP being too close to the step-edge and enabled the forward continuation phase to remain under control, so much so, that despite a longer drop down on the next step, CoM control was kept under control. When exposed to an inconsistent shorter going first, adjustments to CoM control were made in the swing phase prior to contact, which enabled a “regular” amount of foot contact on the inconsistent step and reduced the amount of detectable differences required in CoM control thereafter.

Chapter 6: General Discussion

6.1 Background

Variable step dimensions larger than those specified in the regulations exist on stairs and are present on many stairs where accidents have occurred (J. Cohen et al., 2009; Nemire et al., 2016). Inconsistent stair dimensions are common within the current housing stock (Roys, 2001, 2013) and are strongly linked to serious falls. Inconsistencies are a problem because they will often go undetected by the user (Nemire et al., 2016; Templer, 1992) and thus people are not alerted to the increased risk and are therefore unable to alter their stepping behaviour and make themselves safer. Prior to this thesis, knowledge of fall mechanisms was based on some observations of people on stairs with inconsistencies and theories derived from normal stepping behaviour on stairs with consistent dimensions.

6.2 Purpose

The purpose of this thesis was firstly to establish the mechanisms by which inconsistent dimensions increased the risk of the user and could lead to high fall rates. Stepping mechanics while negotiating stairs with inconsistent rise dimensions (Chapter 3) or inconsistent going dimensions (Chapter 4) were compared to negotiating stairs of consistent dimensions. Changes to balance control when negotiating such stairs were then documented in Chapter 5.

6.3 Summary of Results

6.3.1 Inconsistent rise.

In Chapter 3, it was found that when ascending over a 10 mm inconsistent higher rise followed by a smaller rise, both younger and older adults did not adjust their stepping behaviour in advance of the first inconsistent step. Consequently, both groups experienced an increased risk of a toe-catch and trip on the inconsistently higher step-edge due to reduced clearances. Younger adults did not experience any trips whereas, one older person experienced a trip in the first negotiation of the inconsistent stairs and two other people experienced a trip in subsequent trials. They all tripped on the step-edge of

the inconsistently higher rise. This supports previous evidence and observations of people tripping on a higher step-edge during ascent (Templer, 1992; Templer et al., 1978).

When descending the inconsistent rise stairs, participants also failed to alter their stepping behaviour prior to making contact with the first inconsistent step (smaller step down). This resulted in less time and/or space to be able to pull the foot backwards on to the step. Consequently, the amount of the foot contact over the step decreased for both groups and thus the amount of over-hang increased. In the sub-section of data analysed, individuals did not make alterations in the subsequent four trials, so continued to have reduced contact on the inconsistently higher step. This type of inconsistency in dimensions puts more individuals closer to the crucial 30% overhang limit suggested by Roys and colleagues (Roys, 2013; Roys & Wright, 2005; Wright & Roys, 2005).

The consistent stairs data collected within this thesis indicates that, while descending over the four steps with force plates, there were eight incidents where an individual's overhang was greater than 30%. Two of those occurrences were on Step3. For the first inconsistent rise trial there were fifteen occasions where overhang was greater than 30%, five of those occurred on the inconsistently higher step. There were no slipping events throughout the experiments, but this increase in overstepping incidents, implies that people could have an increased risk of slipping on this type of inconsistency (Roys, 2013; Roys & Wright, 2005; Templer, 1992). To the authors knowledge this mechanism of fall from descending an inconsistent rise has not been considered previously. Yet, when surveying stairs associated with serious falls the presence of an inconsistent rise was almost doubled compared to an inconsistent going (J. Cohen et al., 2009).

6.3.2 Effects of inconsistent rise on balance control

To offset the effects of having a reduced contact length on the first inconsistent rise step during descent, participants needed to use reactive control strategies to maintain balance (Chapter 5). Changes to balance parameters were evidenced during the loading phase, indicating that proprioceptive feedback, most likely from sensors in the feet contribute to good CoM control during stair descent. It has previously been reported that

poor proprioception is linked to slower performance in both ascent and descent for older adults (Tiedemann et al., 2007) and poor balance control in locomotion tasks (Startzell et al., 2000).

From the results presented in Chapter 5, it was evidenced that the compensations to CoM control occurred after contact with the first inconsistent rise step during descent. The margin of stability increased, over which the CoM could be better controlled (Novak et al., 2016). The lowering phase appeared to remain under control onto the second inconsistent step, despite the longer drop down, as vertical CoM velocities were not significantly different compared to the consistent condition. So even though the CoM was closer to the CoP during weight acceptance on Step2, it could be argued that there was less risk for a slip compared to Step3. It could be argued that if the extrapolated CoM (which takes account of both velocity and position of the CoM) exceeds the step-edge during single limb support, there will still be an increased risk of dynamic instability for the older adults. Older adults have previously exhibited a more anterior extrapolated CoM in stair descent (Bosse et al., 2012). Anterior posterior velocity and extrapolated CoM were not considered in the current thesis but should be considered in future projects as it may help to describe dynamic balance control over inconsistent dimensions.

6.3.3 Inconsistent going.

In Chapter 4, during ascent of a longer inconsistent going followed immediately by a shorter going, differences in stepping behaviour were evidenced for the younger and older adults compared to the consistent condition. These differences were noticeable from the walkway and on Step2 (longer going). Younger adults' stepping behaviour resulted in stepping parameters on the inconsistent shorter step (Step3) which were not significantly different to the consistent stairs. However, for older individuals, their stepping behaviour on the walkway and lack of adjustment on Step2 resulted in reduced foot contact length on the shorter step (Step3). This may have increased the chances of under-stepping and missing the step surface completely (Templer, 1992). There were no known incidents during the experimentation. However, the reduced contact length causes

a longer moment arm and thus larger torque about the ankle joint, older adults must generate a larger force to overcome this. This means that, older adults must use a larger proportion of their diminished strength reserve of the plantar flexors to pull the body up (Reeves et al., 2008b; Spanjaard, Reeves, van Dieën, Baltzopoulos, & Maganaris, 2008a). On some occasions or for people with further diminished strength, the pull-up phase may not be achieved successfully.

It is unclear from the data collected for this thesis, if this difference in strategy from the younger and older adults is a result of noticing or not noticing the inconsistency in advance or whether the change was ultimately a result of starting position on the walkway. Starting position may have been influenced by reduced self-efficacy and increased fear of falling for the older adults compared to the younger adults (Reid, Lynn, Musselman, & Costigan, 2007; Tiedemann et al., 2007). The rise and going conditions were presented in a randomised order to the individuals, so the author believes it is unlikely that confidence levels will have impacted the results differently.

In descent of the shorter inconsistent going followed by the longer going, it was clearly evidenced that both groups changed their stepping mechanics prior to contact with the first inconsistent step. This resulted in a foot contact length that was not significantly different to the consistent condition. This means that on this occasion the individuals appeared to be at a similar level of risk as they were on the consistent stairs. This contradicts some of the expectations presented in the literature that inconsistencies are not seen (Templer, 1992) nor acted upon (Roys, 2013). The changes to foot trajectory were detected in late swing (after 78% of swing) prior to contact on the inconsistent step. This behaviour suggests that foot positioning may have been influenced by visual input, meaning that the individuals may have been able to detect, interpret and then create a movement pattern to maintain a foot contact length within normal range. Previous work suggests that individuals may have been fixating two to four steps ahead of their current position, which could have helped the individuals pre-plan the movement in a feed-forward manner (Den Otter et al., 2011; Zietz & Hollands, 2009). Final foot placement may have also been guided by online adjustments, made with the visual information available

from the lower visual field (Timmis et al., 2009). Analysis of gaze behaviour while negotiating stairs with inconsistent dimensions, would strengthen the results found in this thesis and could help our understanding of how visual information is used to guide behaviour.

There was one more observable difference to be found in the stepping mechanics between the younger and older adults. Post hocs revealed that younger adults had a reduction in clearance over the inconsistently longer step-edge (Step2) with a larger standard deviation and thus became more likely to experience a heel catch or trip on that step, although no incidents were observed during testing. Older adults were able to maintain a clearance that was not different to the consistent condition. This again supports that older adults continued to be more cautious after experiencing an inconsistency compared to the younger adults.

6.3.4 Effects of inconsistent going on balance control

In keeping with the adjustments to stepping mechanics, CoM control was also changed during the swing phase prior to contact with the inconsistently shorter going and was expressed within the interaction effects in the vertical CoM accelerations. Younger adults had increased accelerations whereas older adults had reduced accelerations. Interactions were also detected for the length of single limb support across the effected steps, which decreased for the younger adults and increased for the older adults. This is in line with existing literature whereby older adults have been found to use a more cautious strategy and move slower in challenging circumstances, which enables individuals to stay within their maximal capacities such as, when stepping over objects (Weerdesteyn, Hollands, & Hollands, 2018) and in foot placement tasks (Chapman & Hollands, 2006). So even though the base of support was reduced and the distance between the CoM and CoP was reduced at several points throughout stance on the inconsistently shorter step, individuals were able to maintain a dynamic balance control. This would probably be evident in changes in the distribution of joint moments for the younger and older adults and should be considered in future research on inconsistent goings.

6.4 Identification of the Inconsistencies

It seems that adequate early identification of an inconsistency, could help maintain individuals' safety. It was possible to "detect" the inconsistent shorter going in this study and react appropriately prior to contacting it. It was not possible to do this in the inconsistent rise condition. However, identification of the going inconsistency was difficult, as even after negotiating the stairs and adapting their stepping behaviour, individuals were not able to identify how the stairs had been changed, except one. One older male with larger feet was able to state "that step was shorter than the rest" for the going condition. All other older individuals, including other males with large feet, were not able to guess correctly that the going had been changed. Frequently, individuals assumed that the rise was changed in multiple places. Average foot size was not significantly different between the older and younger adults and was normally distributed across both groups. Perhaps this individual was more self-aware potentially from a previous experience, yet he was not able to identify the inconsistency in the rise. For the rise trials some individuals said, something in the bottom half of the stairs was different, but they were not sure exactly where or how the stairs had been changed. This highlights that stair negotiation is as complex to self-interpret as it to navigate. It also shows that retention of important information such as stair dimensions are limited. This lack of awareness in the older adults reflects that something needs to change. Regrettably, the younger adults were not asked at the time if they had noticed differences in the stair dimensions, it would be interesting to document this in future studies.

For this study, to be able to detect the inconsistent rise dimensions in advance, users would need to spend time looking at the riser surface of Step3 and Step4 (Figure 6.1 Part A). There was a complex visual field in the lab while ascending due to the structure of the staircase, this may have inhibited some detection. However, the process of ascending stairs, naturally obstructs the rise. Additionally, visually judging and detecting the change in rise dimensions during descent would be near impossible because the rise itself is not visible to the user from a normal upright position. Surveyors use a "crouch and sight"

technique from the top of the stairs to help identify step-edges that are out of place (Pauls & Barkow, 2013).

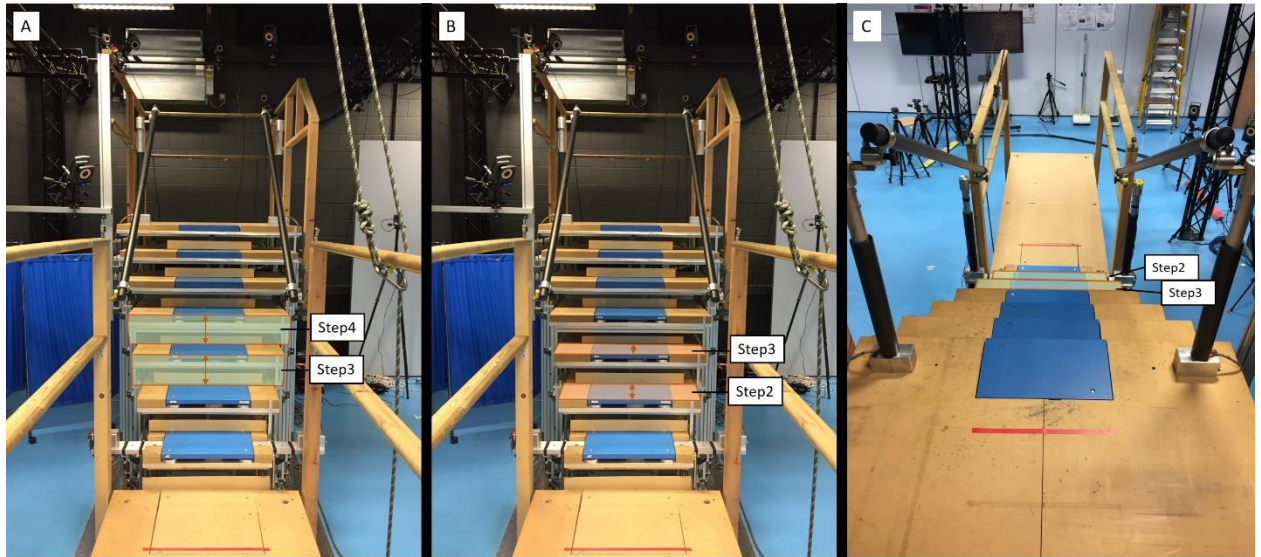

Figure 6.1. Panel A and B shows the ascending view of the stairs from the walkway and Panel C shows the descending view of the stairs from the landing with consistent dimensions, A) has only the riser of Step3 and Step4 highlighted, B) has only the going of Step2 and Step3 highlighted. C) has only the going of Step3 and Step2 highlighted. These highlighted sections would be the only places to observe the inconsistent dimension changes that were used for this study.

Vision research has found that both younger and older adults spend the majority of their time fixating their future travel paths (Zietz & Hollands, 2009), people fixated the step-edge/ edge highlighter the most. Considering that the foot contacts the going portion of the step, people may have failed to see the rise inconsistencies simply because they were not looking or focusing on them. This could also explain why previous observation studies have reported many incidents of tripping on a higher rise step (Johnson & Pauls, 2010; Templer, 1992; Templer et al., 1978).

In comparison, visually detecting changes in going during ascent could be possible. The highlighted sections in Figure 6.1 Part B are more visually consistent and remain in users peripheral view for longer compared to the rise. Perhaps the younger individuals were better able to visually detect the changes in going during ascent than older adults. Previous research reported that younger adults focus slightly further ahead in ascent, 3.5

steps ahead compared to 3 steps ahead for the older adults (Zietz & Hollands, 2009) and therefore might have seen it sooner, giving the younger adults more time to adjust. It may also support differences in eye gaze behaviour and body posture between the younger and older adults (Zietz & Hollands, 2009).

During descent irrespective of condition, the visually available information about the step dimensions has to come from the going (Figure 7.1 Part C). Both groups were able to detect 10 mm change in going and act appropriately to maintain their stepping safety. Previous literature suggests that young and healthy older adults focus 2-4 steps ahead during descent (Zietz & Hollands, 2009), which gives plenty of time for feed-forward processing. The late adjustment to foot trajectory could also be assisted by peripheral vision (Timmis et al., 2009). Therefore, eye tracking would help detect if there are any changes to visual behaviour for individuals as they negotiated the inconsistent dimensions.

The positive adjustment to foot contact length may have only been possible because the magnitude of available going was visually detected first, so enhancing this ability may help identify inconsistencies in other situations. High contrast step-edges such as edge highlighters could help with this (Zietz & Hollands, 2009; Zietz et al., 2011) especially when correctly positioned flush with the step-edge, step-highlighters can improve clearance in both ascent and descent and reduce the amount of overhang in descent (Elliott, Foster, Whitaker, Scally, & Buckley, 2015; Foster et al., 2014) and could improve CoM control as a result (Zietz et al., 2011). It would also be beneficial to have well-lit stairs, as step-edge contrast is improved and confidence improves, thus stepping mechanics are also improved (Hamel, Okita, Higginson, et al., 2005; Thomas et al., 2020). If task demand is increased such as in dual-tasking, talking on the phone while descending, individuals attention will be divided between the stairs and their conversation, either causing an increase in movement variability (Di Giulio, McFadyen, et al., 2020) or potentially preventing the proactive change in stepping behaviour on the inconsistently shorter going step. A similar level of inaccuracy may be observed when a user is carrying a load that obscures the stairs (Timmis et al., 2009). No adaptation and large variability

could increase the overhang to more than that observed in the rise chapter of this thesis (Roys, 2013) and could lead to a serious fall.

6.5 Limitations

The experimental chapters presented in this thesis were all completed in a laboratory environment, with custom built stairs, these stairs do not look like regular home stairs, there were no top surface such as a carpet or other floor covering. However, the central walking path on the non-instrumented steps were painted blue to match the instrumented steps, to attempt to look visually similar. Even so, the visual information available during ascent and descent are very different within the stair setup (Figure 6.1), this may have enhanced the ability to detect the going in descent compared to the rise and may have also enabled the younger adults to determine the dimensions changes for the going while they ascended.

In between stair configurations, individuals were asked to leave the room while the researcher made the necessary dimension adjustments. Participants were told that the stair dimensions may or may not be changed while they left the room. This could have heightened anxiety particularly for the older adults who generally tend to have increased fear of falling (Keskin et al., 2008; Reid, Novak, Brouwer, & Costigan, 2011; Tiedemann et al., 2007) when negotiating stairs compared to younger adults. Anxiety in individuals may have presented as changes in posture and possible altered head position (Zietz et al., 2011) which could have negatively affected CoM position and control. However, as the inconsistent conditions were presented in a random order and individuals were not explicitly told that the first condition had consistent dimensions the research team believe that this would have balanced out across participants and conditions.

All individuals wore a safety-harness, which could have impeded normal movement and were asked to use a step-over-step technique. This may not have been their preferred way of negotiating the stairs particularly for the older adults some of which first negotiated the stairs by holding the handrail. Holding the handrail has been shown to improve balance control during descent in younger and older adults and can

reduce lower-limb joint moments in ascent (Reeves et al., 2008a). Everybody in the study was given time to familiarise with the setup, be comfortable with the harness and the task and were comfortable to proceed. Additionally, no one appeared to have issues with balance control on the stairs. The author believes that, the lack of handrail exposes the worst-case response and the harness could have provided some security to off-set their possible fear. If people do use the handrail in real life they should be safer or at least be more able to arrest a fall should one happen (Gosine et al., 2019; Startzell et al., 2000).

In terms of methodological limitations, this study used a rigid 2D template to represent the shoe sole. This template was used to calculate the clearances and percentage foot contact lengths, as identified within Chapter 3 and Chapter 4. This shoe sole did not account for differences in toe-spring height, where the sole of the shoe was vertically lifted towards the toes. The toe-spring correction was estimated from a separate pilot study and applied retrospectively to participants data based on available markers on the foot. This may have over-estimated some individual's ascent clearances and underestimated others. However, an individualised toe-spring correction was used across conditions for each participant, minimizing the within participant errors. Future studies using 2D outlines, should directly measure the toe-spring gap so that true clearances can be determined. In descent, the foot model used in this thesis seemed appropriate for measuring clearance from the sole to the step-edges as values were similar to those previously reported on the mid-flight step-edges of a more complex 3D foot model (Telonio et al., 2013). Our model accounts for rotation of the foot, different styles, thickness of soles and types of footwear. Clearances that rely solely on anatomical positioning of a marker on the heel for example (Muhaidat et al., 2011; Zietz et al., 2011) may reflect how close the protruding marker is to the step-edge and does not represent the part of the shoe which is most likely to contact the step-edge (Telonio et al., 2013). As such, horizontal heel marker clearances reported in Zietz and Hollands (2011) were four to three times larger than clearances reported in this study and would not be as helpful in deducing risk of heel catch on steps with inconsistent dimensions.

In this thesis, the amount of foot contact over the steps for the younger adults were similar to the portion not overhanging the step in the Muhaidat and colleagues study (2011), on average younger adults of this thesis had 2% less of their foot length on the steps in the consistent condition. This might have been caused by differences in reference position of the shoe outline step-edge rather than to just the heel marker used previously or differences may have been increased due to differences in step dimensions between this and previous studies (Muhaidat et al., 2011).

Additionally, for this thesis the 2D outline was created by tracing around the participants shoes whilst they were seated, the actual shoe sole was likely to deform more when supporting the participants full body weight in single-limb support, increasing the contact area and thus increasing the perceived contact length over the step. To overcome this factor percentage foot contact lengths were determined in the first frame after a vertical force threshold of 50 N was reached. This minimized the effects of deformation on the results. Computation of the plantarflexion and progression angle of the foot during descent would aid in better understanding of how individuals adapted to improve their foot contact length on the step with an inconsistent shorter going. Without these outcome measures, it is not possible to decipher between individuals who may have pulled their foot straight back on the shorter step and those who might have either rotated their foot more in the vertical plane or reduced their plantar flexion angle to improve the contact length.

The inconsistencies used within this thesis, would be termed as “random” rather than “systemic” within the forensic type literature (Johnson & Pauls, 2010), it is unlikely that the same inconsistency would exist on other stairs in exactly the same way. Random inconsistencies might occur overtime due to wear and tear, weathering or rotting of the stair structure, or building errors during the construction process. The 10 mm inconsistency used within this thesis is in line with magnitudes found within the literature (J. Cohen et al., 2009). It is not clear if this magnitude is likely to occur in the mid-flight region, or if two consecutive steps would be affected. In the opinion of technical advisors from the BRE (Building Research Establishment), it is more often the case that the pitch of

the staircase would remain constant. The best way to achieve a constant pitch on our mechanical staircase was to manipulate one step-edge resulting in two steps being affected. As descent is associated with more falls than ascent, we ensured the more “dangerous” inconsistency was experienced first in the rise condition during ascent and descent and during descent of the going condition, the dangerous step was always followed by a safer step. This could have improved the ability to control balance after the inconsistency and allow participants to proceed safely. However, the research team do not believe the main outcomes from this thesis would be different should we have manipulated only one step to cause the inconsistency.

6.6 Recommendations and Future Directions

The current thesis was able to challenge healthy individuals CoM control in a controlled environment and document findings that have not yet been reported in the literature. This thesis presents two scenarios in which the dimensions were inconsistent, future work should determine the thresholds at which detection is possible, if it is possible for both rise and going scenarios. Changes in stepping behaviour prior to contact with an inconsistent step might help identify these thresholds. Tracking and challenging gaze behaviour in those stepping scenarios would help clarify how visual behaviour is used to guide safe stepping. This type of experimental evidence may also support alterations to building legislations and practices.

Professionals like Mike Roys who have devoted their career to stair fall investigation, recommend that, inconsistencies should not exist. Offending stairs should be fixed or replaced (Roys, 2013). Total removal would be ideal; however, this thesis would currently support the removal of inconsistent rise dimensions, more experimentation is needed to support the removal of inconsistent goings. Within the building and housing industry, despite simple techniques and tools being available to detect inconsistencies in step dimensions, there is a failure in identification or reporting of such inconsistencies (Johnson & Pauls, 2010). Accountability may not be sort until decades after completion when an individual seeks compensation for their or family members

serious stair fall, then the question who or rather what is to blame? Considering it is unlikely that inconsistencies will be completely eliminated from stairs in the future it is recommended that larger goings are incorporated into designs to off-set the impact of dimension variability (Roys, 2001, 2013; Wright & Roys, 2008). Even this would still require a lot cooperation from multiple industries.

Another stair research team actually suggested that the top step should have a smaller rise compared to the rest of the stairs, as this would increase foot clearances over that step for older adults in both ascent and descent (Kunzler et al., 2018). However, this research was only performed over three steps. It is not yet known how this alteration could affect the foot placements and clearances on subsequent steps on longer staircases or how this type of inconsistency would impact upon CoM control. Our research has found a reduced contact length after a smaller rise, which may or may not occur if this smaller rise was the first step down. The inconsistency could give the user “false” expectations about the positions of subsequent steps and similar to the results of this thesis, may create an unexpected longer step down, increasing ground reaction forces and loading rates on the second step down. It could also affect foot clearances on the next steps, increase trip risk and could have greater implications on foot contact further down the stairs, the true effect is not currently known and needs experimentally testing. Therefore, investigators should be extremely careful with the recommendations they make regarding inconsistent dimensions.

Forensic-type literature has already reported high fall rates on stairs in the home with systematic top step defects (Johnson & Pauls, 2010) which technically break the building variability regulations for stairs, however these inconsistencies seem to be repeatedly over-looked within the building industry. It is estimated that 90% of newer homes, have stairs with a longer going on the first step down compared to the rest of the steps (Pauls & Harbuck, 2008). This is caused by the landing step-edge missing material to form the step-edge which is incorporated on all the other edges. According to findings of this thesis, one might expect the user to adapt their foot position for each of the shorter steps, however due the false sense of security felt on the first step down and due to the

close proximity of the inconsistency to the start of the stair descent, the inconsistency might not be noticed or expected, consequently the chances of over-stepping could increase. The size of the subsequent step-edge may also increase the risk of users catching their heel on the riser as they lift their foot prior to toe-off causing a trip type event (Pauls, 2013). More serious injury could result from a fall near the top of the stairs verses a fall towards the bottom.

As biomechanists, we not only need to continue to test the effects of inconsistent dimensions on stepping performance and associated fall risk to support initiatives to achieve the longer term goals of eliminating inconsistent dimensions, but we also need to develop interventions that help individuals become safer on stairs now. It is imperative to help individuals become more aware of the dangers of negotiating stairs. Attention must be brought to individuals in their own homes, where they might falsely feel safer compared to less familiar environments. When an individual feels more confident and safer, they are more likely to take more risks which increase the potential for a fall to occur. Heightening awareness of inconsistencies and the inherent dangers of stairs might be an effective fall reduction intervention, future studies should consider experimentally testing this.

Taking advantage of new technologies such as using marker-less motion capture systems would aid collection of stepping behaviours in more familiar surroundings, the cameras could be set up in a home environment and collect data over the course of several days. The marker-less motion capture could be paired with specialist footwear designed to detect foot clearances, foot contact and CoP on each step. Such technology is currently being developed and has potential to increase the amount and quality of data that is obtained in non-laboratory settings (Selvaraj et al., 2019). Controversially, asking participants to traverse steps that knowingly contain large inconsistencies without the use of a safety harness may be unethical and should be considered carefully in future research. But investigating step dimensions post fall as many studies have done (H. Cohen, 2000; J. Cohen et al., 2009; Nagata, 2014), could be too late for some individuals. The industry should take a proactive approach to experimental research that helps establish

the effect of different magnitudes and types of inconsistencies that exist within the home and public environment.

There are many factors previously summarised in the literature that could help to more accurately document the impact of inconsistencies in stair falls and then to help reduce them (Pauls & Barkow, 2013). It is necessary for researchers to be holistic and thorough in their approach to stair fall research. Reducing the number of falls on stairs with inconsistent dimensions would require instilling change within the building industry and providing stair users with the correct tools so that they can improve their stepping characteristics, either consciously through participation in fall prevention programs or unconsciously through the use of visual tools which indirectly could improve stepping mechanics, these would need to be developed. In the meantime, collecting better information concerning stair falls would substantially enhance predictions and could influence funding to help support the longer-term projects. Where serious falls have occurred, it would be beneficial to have thorough forensic data of the location, condition the availability/type of handrails, the nose to nose dimensions of each step.

6.7 Changing Behaviour on Stairs

This thesis has shown that healthy individuals have the capacity to adjust stepping behaviours prior to contacting an inconsistent going. This change was possibly due to visually detecting the difference early enough, permitting a change to the movement plan. When the individuals did not adapt to the inconsistent rise they were put at increased risk of a trip in ascent and slip in descent. Finding ways that promote early detection and permit safer stepping strategies of stair users has the potential to improve stair safety and reduce the occurrence of some falls, however, more research is needed to determine if these changes would be beneficial or detrimental to stair safety in the long-run.

Good visualisations of the stairs could improve stepping performance, however, there is a need to better understand how visual data is used and processed prior to and during the stair negotiation process. As already mentioned high-contrast step-edges (Foster et al., 2014) and well-lit stairs, improve stepping mechanics (Christina & Cavanagh,

2002; Hamel, Okita, Higginson, et al., 2005; Thomas et al., 2020; Zietz et al., 2011), it would therefore be beneficial to promote the use of bright bulbs in home stairwells (Thomas et al., 2020), as well as choosing a suitable finish/ covering on the stairs that promotes high contrast of the step-edges (Startzell et al., 2000). Visual behaviour interventions that encourage users to spend more time looking at step-edges before stepping onto them might help in the feed forward processing and enable users to clear and then make contact with improved accuracy (Zietz & Hollands, 2009).

Making an inconsistent step stand out compared to the rest of the stairs might be a positive development in trying to avoid falls. The use of optical illusions such as the vertical horizontal illusion (Elliott et al., 2015; Foster et al., 2015), could also help improve clearances on steps with inconsistent higher rise steps. The illusion gives the rise it is placed on, a taller appearance and resulted in individuals increasing their foot clearance by approximately 10 mm over the steps it was placed on (Foster et al., 2015). This may be a suitable intervention to minimise the risk of tripping on the 10 mm higher rise step during ascent for both healthy younger and older groups, as clearances in this thesis were reduced by approximately 9 mm. Future work should identify if this type of illusion can cause a magnitude of change in clearance that is relative to the size of the inconsistency in riser height. Additionally, based on the findings from this thesis, the inconsistent rise should be detectable from both directions. The horizontal portion of the illusions could also be effective in promoting safer stepping behaviour in descent, if it is applied as step-edge highlighter (visible from above). More work is needed to determine if CoM control could be compromised due to the changes in stepping behaviour. An illusion could be used on a step identified as “dangerous” and might be easy to implement in public spaces, it would be harder to implement within homes prior to a fall. Homeowners might be reluctant to ruin the aesthetics of their stairs. Researchers could work with the building industry to provide such illusions where an inconsistency is identified, and a remodel may be cost-prohibitive.

A preventative fall strategy may be to encourage conscious and at least light handrail use in all individuals (Reeves et al., 2008a), as this helps to redistribute lower-limb

joint moments during ascent, has improved peak CoM-CoP separation in descent (Reeves et al., 2008a), reduces mediolateral velocity and helps improve stability (Reid et al., 2011). The handrail also proves a suitable grasping device for arresting incidents such as a slips (Gosine et al., 2019). However, handrail dependency is also related to poor balance performance in other tasks, reduced self-efficacy and decreased strength which is predictive of subsequent mortality (Stessman, Rottenberg, & Jacobs, 2017). Despite this, in a 12 month follow up period, the individuals identified with severe balance issues and who were heavily reliant on using the handrails as they negotiated stairs, were the only group not to experience any stair falls (Ackermans, 2019; Ackermans et al., 2020). It was found in another study that even younger adults who do not typically use the handrail, had reduced cadence when they used one, making them a little bit safer (Reid et al., 2011). It is unknown if longer-term use would continue to illicit this response.

6.8 Conclusion

This thesis was able to document how stepping mechanics and balance control were impacted for younger and older adults, as they negotiated stairs with inconsistent rise and inconsistent going dimensions compared to stairs with consistent dimensions (similar to home stairs). The inconsistent rise condition did not illicit a change in behaviour prior to contact with the inconsistent step thus a reactive response was required to control balance during descent. Because of this lack of adaptation, the rise inconsistency seemed to be more dangerous for the healthy participants of this study due to an increase in trip risk during ascent and increased over-stepping risk in descent. Whereas, on an inconsistent shorter going, individuals were able to demonstrate, seemingly subconscious, proactive adjustments to their stepping behaviour which reduced the changes needed to maintain balance thereafter. Individuals who are frailer or who are being less cautious may not adapt in the same way. Considering the high prevalence of falls on stairs which have large inconsistencies it is vital that biomechanical stair research continues to advance our understanding of why inconsistencies are so dangerous. Future research should explore how to improve stair safety on inconsistencies, the use of visual manipulations, encouraging the use of the handrails and promoting more cautious

behaviours of the user could all help reduce the number of falls. There is a need for collaborations between industries in documenting the presence of inconsistencies on stairs, either fixing the dangerous step or finding a way to encourage subconscious safer stepping behaviour. Only then can fall prevention initiatives be developed and legislation be changed so that stair safety is improved in the future.

Appendix A Camera Setup

As the first PhD student to test on the new customised staircase, I was tasked with setting up the stairs and testing procedures in such a way that would benefit other incoming students and research projects as well as preparing for my own study, the most time consuming was the camera setup. There were many challenges to overcome. The lab is a versatile space, as such the stairs were placed towards the back corner of the lab as to not interfere with Motek balance platform and pit. Cameras were shared between multiple research projects that had completely different needs and capture volumes.

To be able to calibrate the large capture volume that the walkway, stairs and landing presented, obtain accurate marker data throughout the whole stair movement with minimal gaps; especially for the feet markers, a full-body calibration on the walkway and have essential markers visible from the landing, it was necessary to integrate 24 cameras. We used a combination of Vicon TX10, TX160 and Bonita cameras. I was grateful to have my colleague Thijs Ackermans join me at this stage. Most of the cameras had to be moved in weekly blocks to accommodate all the other research projects.

The cameras not only had to be changed between projects but when the stairs were in a steep or shallow configuration as both the walkway and landing levels were changed in the process. To facilitate faster setup times, the use of more optimal camera positions and obtaining good data during collections, we produced visual templates for the two setups used between our studies that anyone using the stairs could use as a guide. The template incorporated screen shots of each individual camera view of the step-edge clusters on the stairs (described in Appendix B) and the position of the other cameras in view (Figure A.1). This combined with tape lines placed on the floor for tripods and on the trucing housing the camera brackets provided a quick reference to check cameras were appropriately placed. There were always some adjusting of focal lengths, zoom and apertures and then calibrations and several pilot tests of foot markers and head markers prior to any participant visit. Spending the time to do these prior to each of our testing blocks substantially improved the quality of our data collections and reduced gaps.

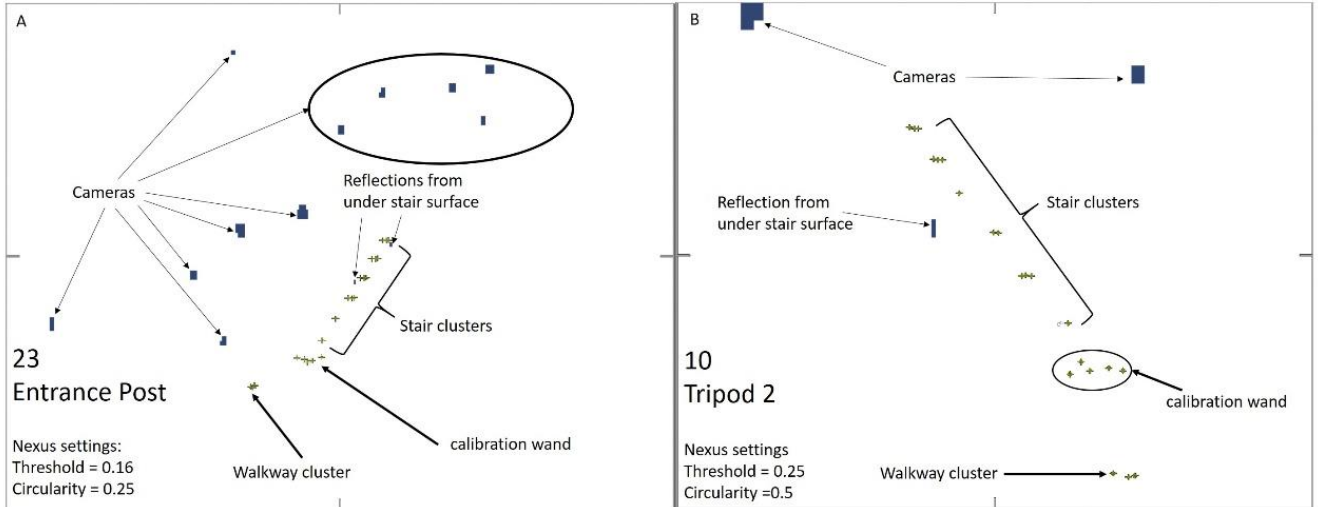

Figure A.1. Example of camera views used in template for camera setup for A) a camera positioned far away from the stairs and B) a camera positioned closer to the stairs. Notations are added for convenience, ■ Indicates masked areas and ✚ indicates reflective markers.

Appendix B Defining Step-Edges

It was necessary to define the step-edges in between the three conditions of my study for three reasons: 1) so the force plates were correctly located within the capture volume, 2) so that each step-edge was defined for the Matlab scripts processing foot clearance and foot contact lengths, 3) so the centre of pressure (CoP) could be determined relative to the step-edges.

For consistency in marker placement and so that the markers used could be removed from the stairs during testing, we developed a corner cluster which used three markers at known distances (Figure B.1), these were later 3D printed with screw pins precisely located with respect to the underlying forceplate, so the 14 mm retro-reflective markers were attached (Figure B.2). Each step and the walkway had a specific cluster. The only exception was Step1 which had the calibration wand on it to define the Lab origin. The clusters to be used on steps with force plates had an additional lip underneath them to help maintain a snug fit and prevent movement. The clusters were designed to fit on the right corner of each force plate and wooden insert and can be visualised in Figure B.3.

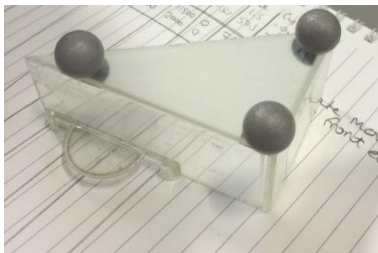

Figure B.1. Step-edge cluster prototype.



Figure B.2. 3D printed step-edge clusters.

For every stair condition a three second capture of the step-edge markers and calibration wand was taken within the Nexus system. This trial data was exported, averaged and was instantly placed into an excel template that adjusted for the known dimensions of the clusters so that correct force plate edges could be determined. The values were manually placed into the Nexus system template and saved ready for the next participant trials. The captured cluster data was also used in the Matlab script with

corrections for the known cluster dimensions so the correct step-edge locations could be determined throughout testing.

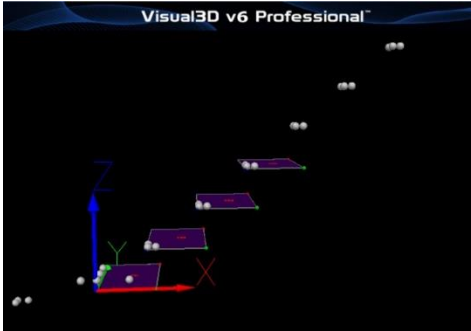

Figure B.3. Visual 3D capture of the step-edge markers, and calibration wand defining the global origin.

Appendix C Anti-Tipping Mechanism for Forceplates

During stair negotiation it is common for users to overhang the step-edge, this often places the CoP on the front edge of the steps and outside of the base of support. Due to the design of the Kistler forceplates, when such loads were applied to the exposed edge, the forceplates would lift out of their rear feet and rotate/tip, causing a fall risk for individuals. Therefore, for safety reasons it was vital to prevent tipping of the forceplates when weight was applied to the forceplate edge.

Several mechanisms were trialed, the original mechanism consisted of two metal plates screwed into place over the two back corners (Figure C.1 Part A), while this prevented some tipping from occurring it also created additional impact forces in the forceplate curves and inaccuracies in centre of pressure data especially when individuals stepped onto the step-edge. To overcome this Ian Poole the Senior Technician and myself tested the effect of spring loaded brackets on the force plates and centre of pressure data using a series of tests using multiple compression lengths, weights and force application points. Due to the forceplate cable running through the centre of the steps, we first tested two brackets evenly spaced along the back of the forceplate. However, it was not possible to set the spring lengths equally therefore, force application was not evenly distributed.

After further testing we were happy that one off-centre bracket (Figure C.1 Part C) was sufficient to prevent tipping and when zeroed the force data and centre of pressure data were comparable to the data when the spring was absent. Consequently we installed the spring mechanism on all four of the force plate steps. The cross section of the step and spring mechanism can be seen in Figure C.2 The compression springs were rated at 4.04 N/mm, they were compressed to 25 mm exerting a force of 101 N on the rear of the forceplate. This spring length did not cause any unwanted tipping at the back and prevented tipping when the front edge was loaded.

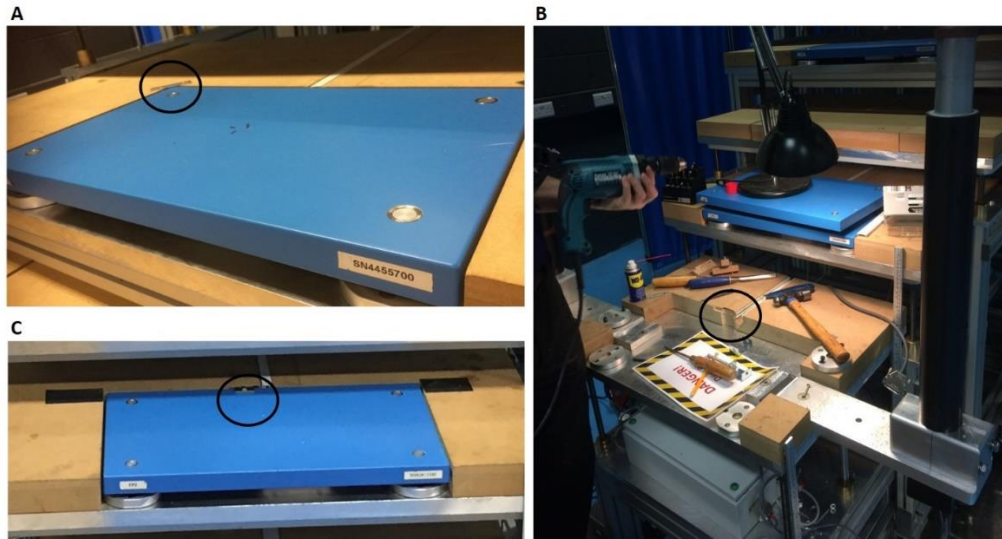

Figure C.1. Installation of anti-tipping mechanism for user's safety, A) initial mechanism, B) installation process, involving cutting out of wooden material to allow new anti-tipping bracket to be fitted in to the step C) new spring-loaded bracket installed.

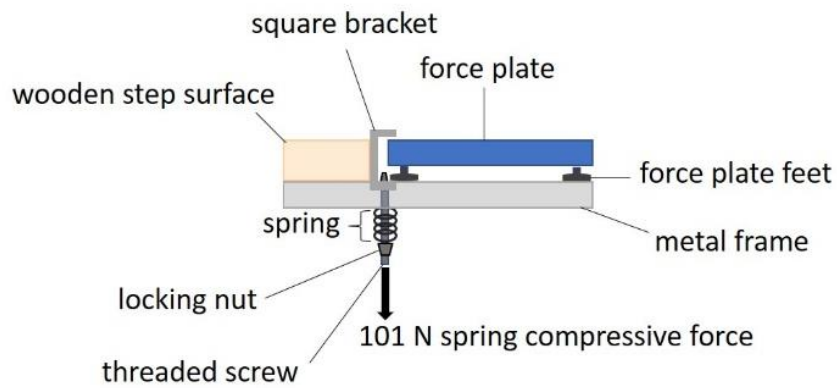

Figure C.2. Cross section of step and anti-tipping spring mechanism.

Appendix D Table D.1. Comprehensive Data for Consistent Versus Inconsistent Rise Conditions.

Variables	Younger adults				Older adults				Condition effect		Age effect		Interaction effect		
	Consistent		Inconsistent Rise		Consistent		Inconsistent Rise		F value	Sig.	F value	Sig.	F value	Sig.	
	Mean	SD	Mean	SD	Mean	SD	Mean	SD							
A Ascent vertical foot clearance (mm)															
Step1	55	17	52	15	60	19	54	20	5.9	.019					
Step2	39	12	36	13	40	14	38	15	2.2	.148					
Step3	42	11	34	12	42	18	32	20	48.4	.001					
Step4	37	11	47	15	38	15	55	18	68.5	.001			4.2	.045	
Step5	35	10	38	12	38	18	40	19	4.4	.040					
Step6	35	10	31	10	38	13	38	14	1.4	.247					
Landing	48	19	50	18	50	19	53	20	2.2	.145					
Ascent percentage foot contact (%)															
Step1	70.9	9.0	71.0	9.6	78.2	9.7	77.7	10.3	0.0	.832	8.3	.006			
Step2	67.6	10.2	66.8	12.0	77.5	11.1	77.3	11.2	0.3	.603	13.3	.001			
Step3	66.9	10.4	64.3	11.9	76.3	10.7	76.2	9.7	3.2	.081	15.6	.001			
Step4	64.5	10.3	68.7	9.9	74.9	11.6	77.7	12.1	16.4	.001	12.1	.001			
B Descent horizontal foot clearance (mm)															
Landing	19	11	18	12	23	12	21	12	3.3	.074					
Step6	23	10	26	13	30	15	29	15	1.3	.259					
Step5	22	11	22	12	28	14	32	16	3.6	.064	5.6	.022			
Step4	20	7	20	9	26	14	27	17	0.4	.534	3.9	.054			
Step3	17	10	18	15	26	14	23	13	0.8	.378	4.0	.050			
Step2	21	9	22	11	23	12	26	15	2.9	.093					
Step1	41	19	41	19	39	29	38	29	0.0	.837					
Descent percentage foot contact (%)															
Step4	79.3	7.0	81.5	9.0	84.5	9.1	84.0	10.2	2.2	.144			6.2	.016	
Step3	81.3	6.4	79.8	8.4	85.5	7.7	83.4	9.1	9.1	.004					
Step2	81.1	7.2	85.5	7.3	85.3	8.4	89.1	9.3	52.5	.001					
Step1	82.5	6.3	83.1	7.8	87.2	6.9	87.2	8.8	0.2	.692	5.3	.025			

Appendix E Table E.1. Comprehensive Data for Consistent Versus Inconsistent Going Conditions.

Variables	Younger adults				Older adults				Condition effect		Age effect		Interaction effect	
	Consistent		Inconsistent Going		Consistent		Inconsistent Going		F value	Sig.	F value	Sig.	F value	Sig.
	Mean	SD	Mean	SD	Mean	SD	Mean	SD						
A Descent horizontal foot clearance (mm)														
Landing	19	11	18	13	23	12	23	12	0.2	.689				
Step6	23	10	24	12	30	15	28	16	0.2	.894				
Step5	22	11	23	11	28	14	29	14	0.4	.532				
Step4	20	7	19	9	26	14	23	15	2.2	.148				
Step3	17	10	24	15	26	14	30	17	18.6	.000	4.0	.051		
Step2	21	9	16	11	23	12	23	18	5.2	.027				
Step1	41	19	41	19	39	29	38	32	0.1	.788				
<i>Descent percentage foot contact length (%)</i>														
Step4	79.3	7.0	78.9	8.5	84.5	9.0	84.8	10.1	0.0	.940	6.0	.017		
Step3	81.3	6.4	80.4	5.4	85.5	7.7	84.4	9.4	2.5	.121	4.7	.035		
Step2	81.1	7.2	82.9	6.6	85.3	8.4	87.2	9.3	8.5	.005	4.3	.042		
Step1	82.5	6.3	86.5	6.7	87.2	6.9	88.0	8.0	20.7	.000			9.25	.004
B Ascent vertical foot clearance (mm)														
Step1	54	17	53	18	60	19	55	20	3.1	.085				
Step2	38	12	37	13	40	14	40	19	0.1	.781				
Step3	41	10	45	14	42	18	44	19	7.2	.009				
Step4	37	11	40	10	38	15	41	21	2.4	.125				
Step5	35	10	39	13	38	18	38	20	2.9	.096				
Step6	35	9	37	10	38	13	42	18	4.1	.047				
Landing	48	18	51	19	50	19	53	23	4.0	.050				
<i>Ascent percentage foot contact length (%)</i>														
Step1	71.2	9.0	71.3	9.3	78.2	9.7	75.3	9.6	3.1	.083	5.6	.021		
Step2	67.3	10.1	73.0	10.6	77.5	11.1	78.0	11.6	13.1	.001	7.8	.007	9.3	.003
Step3	66.8	10.2	69.0	9.8	76.3	10.7	73.5	10.9	0.1	.709	7.3	.009	8.8	.004
Step4	64.1	10.2	72.1	10.9	74.9	11.6	77.2	12.9	27.2	.000	7.7	.007	8.1	.006

References

- Ackermans, T. M. A. (2019). *Biomechanical profiling of stair negotiation and fall risk detection in older people (Doctoral Theses)*. Liverpool John Moores University.
- Ackermans, T. M. A., Francksen, N. C., Casana-Eslava, R. V., Lees, C., Baltzopoulos, V., Lisboa, P. J. G., ... Maganaris, C. N. (2019). A novel multivariate approach for biomechanical profiling of stair negotiation. *Experimental Gerontology*, *124*.
<https://doi.org/10.1016/j.exger.2019.110646>
- Ackermans, T. M. A., Francksen, N., Lees, C., Papatzika, F., Arampatzis, A., Baltzopoulos, V., ... Maganaris, C. (2020). Prediction of balance perturbations and falls on stairs in older people using a biomechanical profiling approach: A 12-month longitudinal study. *The Journals of Gerontology: Series A*, 1–10. <https://doi.org/10.1093/gerona/glaa130>
- Blazewick, D. H., Chounthirath, T., Hodges, N. L., Collins, C. L., & Smith, G. A. (2018). Stair-related injuries treated in United States emergency departments. *American Journal of Emergency Medicine*, *36*(4), 608–614. <https://doi.org/10.1016/j.ajem.2017.09.034>
- Bosse, I., Oberländer, K. D., Savelberg, H. H., Meijer, K., Brüggemann, G. P., & Karamanidis, K. (2012). Dynamic stability control in younger and older adults during stair descent. *Human Movement Science*, *31*(6), 1560–1570. <https://doi.org/10.1016/j.humov.2012.05.003>
- BSI. *BS 5395-1: Stairs. Code of practice for the design of stairs with straight flights and winders*. (2010).
- Buckley, J. G., Cooper, G., Maganaris, C. N., & Reeves, N. D. (2013). Is stair descent in the elderly associated with periods of high centre of mass downward accelerations? *Experimental Gerontology*, *48*(2), 283–289. <https://doi.org/10.1016/j.exger.2012.11.003>
- Buckley, J. G., Heasley, K. J., Scally, A., & Elliott, D. B. (2005). The effects of blurring vision on medio-lateral balance during stepping up or down to a new level in the elderly. *Gait and Posture*, *22*(2), 146–153. <https://doi.org/10.1016/j.gaitpost.2004.08.006>
- Chapman, G. J., & Hollands, M. A. (2006). *Evidence for a link between changes to gaze behaviour and risk of falling in older adults during adaptive locomotion*. 24, 288–294. <https://doi.org/10.1016/j.gaitpost.2005.10.002>
- Christina, K. A., & Cavanagh, P. R. (2002). Ground reaction forces and frictional demands during stair descent: Effects of age and illumination. *Gait and Posture*, *15*(2), 153–158. [https://doi.org/10.1016/S0966-6362\(01\)00164-3](https://doi.org/10.1016/S0966-6362(01)00164-3)
- Cohen, H. (2000). Field study of stair descent. *Ergonomics in Design*, *8*(2), 11–15. <https://doi.org/10.1177/106480460000800203>
- Cohen, J., LaRue, C. A., & Cohen, H. (2009). Stairway falls: an ergonomic analysis of 80 cases. *Professional Safety*, (January), 27–33.
- Dempster, W. T. (1955). Space requirements of the seated operator: geometrical, kinematic, and mechanical aspects other body with special reference to the limbs. In *WADC-TR-55-159*. Springfield, Ohio: Carpenter Litho & Prtg. Co.
- Den Otter, A. R., Hoogwerf, M., & Van Der Woude, L. H. (2011). The role of tread fixations in the visual control of stair walking. *Gait and Posture*, *34*(2), 169–173. <https://doi.org/10.1016/j.gaitpost.2011.04.004>
- Di Giulio, I., McFadyen, B. J., Blanchet, S., Reeves, N. D., Baltzopoulos, V., & Maganaris, C. N.

- (2020). Mobile phone use impairs stair gait: A pilot study on young adults. *Applied Ergonomics*, 84(November 2019), 103009. <https://doi.org/10.1016/j.apergo.2019.103009>
- Di Giulio, I., Reeves, N. D., Roys, M., Buckley, J. G., Jones, D. A., Gavin, J. P., ... Maganaris, C. N. (2020). Stair gait in older adults worsens with smaller step treads and when transitioning between level and stair walking. *Frontiers in Sports and Active Living*, 2(63), 105–121. <https://doi.org/10.3389/fspor.2020.00063>
- Duckham, R. L., Procter-Gray, E., Hannan, M. T., Leveille, S. G., Lipsitz, L. A., & Li, W. (2013). Sex differences in circumstances and consequences of outdoor and indoor falls in older adults in the MOBILIZE Boston cohort study. *BMC Geriatrics*, 13(1), 133. <https://doi.org/10.1186/1471-2318-13-133>
- Elliott, D. B., Foster, R. J., Whitaker, D., Scally, A. J., & Buckley, J. G. (2015). Analysis of lower limb movement to determine the effect of manipulating the appearance of stairs to improve safety: a linked series of laboratory-based, repeated measures studies. *Public Health Research*, 3(8), 1–56. <https://doi.org/10.3310/phr03080>
- Foster, R. J., Hotchkiss, J., Buckley, J. G., & Elliott, D. B. (2014). Safety on stairs: Influence of a tread edge highlighter and its position. *Experimental Gerontology*, 55, 152–158. <https://doi.org/10.1016/j.exger.2014.04.009>
- Foster, R. J., Maganaris, C. N., Reeves, N. D., & Buckley, J. G. (2019). Centre of mass control is reduced in older people when descending stairs at an increased riser height. *Gait & Posture*, 73(August), 305–314. <https://doi.org/10.1016/j.gaitpost.2019.08.004>
- Foster, R. J., Whitaker, D., Scally, A. J., Buckley, J. G., & Elliott, D. B. (2015). What you see is what you step: The horizontal-vertical illusion increases toe clearance in older adults during stair ascent. *Investigative Ophthalmology and Visual Science*, 56(5), 2950–2957. <https://doi.org/10.1167/iovs.14-16018>
- Francksen, N. C., Ackermans, T. M. A., Holzer, D., Ebner, S. A., Maganaris, C. N., Hollands, M. A., ... Brien, T. D. O. (2020). Negotiating stairs with an inconsistent riser : Implications for stepping safety. *Applied Ergonomics*, 87(July 2019), 103131. <https://doi.org/10.1016/j.apergo.2020.103131>
- Gosine, P., Komisar, V., & Novak, A. C. (2019). Characterizing the demands of backward balance loss and fall recovery during stair descent to prevent injury. *Applied Ergonomics*, 81(August), 102900. <https://doi.org/10.1016/j.apergo.2019.102900>
- Hale, A. R., & Glendon, A. I. (1987). *Individual Behaviour in the Control of Danger*. Amsterdam: Elsevier.
- Hamel, K. A., Okita, N., Bus, S. A., & Cavanagh, P. R. (2005). A comparison of foot/ground interaction during stair negotiation and level walking in young and older women. *Ergonomics*, 48(8), 1047–1056. <https://doi.org/10.1080/00140130500193665>
- Hamel, K. A., Okita, N., Higginson, J. S., & Cavanagh, P. R. (2005). Foot clearance during stair descent: Effects of age and illumination. *Gait and Posture*, 21(2), 135–140. <https://doi.org/10.1016/j.gaitpost.2004.01.006>
- Hanavan, E. P. (1964). *A mathematical model of the human body*. Retrieved from <http://apps.dtic.mil/dtic/tr/fulltext/u2/608463.pdf>
- Hashish, R., Toney-bolger, M. E., Sharpe, S. S., Lester, B. D., & Mulliken, A. (2017). Gait & Posture Texting during stair negotiation and implications for fall risk. *Gait & Posture*, 58(August), 409–414. <https://doi.org/10.1016/j.gaitpost.2017.09.004>

- Heijnen, M. J. H., & Rietdyk, S. (2016). Falls in young adults: Perceived causes and environmental factors assessed with a daily online survey. *Human Movement Science, 46*, 86–95. <https://doi.org/10.1016/j.humov.2015.12.007>
- Heinrich, S., Rapp, K., Rissmann, U., Becker, C., & König, H. H. (2010). Cost of falls in old age: A systematic review. *Osteoporosis International, 21*(6), 891–902. <https://doi.org/10.1007/s00198-009-1100-1>
- HM Government. *Document K: Access to and use of buildings.* , (2000).
- HM Government. *Protection from falling, collision and impact.* , (2013).
- Hortobágyi, T., & Devita, P. (2000). Muscle pre- and coactivity during downward stepping are associated with leg stiffness in aging. *Journal of Electromyography and Kinesiology, 10*(2), 117–126. [https://doi.org/10.1016/S1050-6411\(99\)00026-7](https://doi.org/10.1016/S1050-6411(99)00026-7)
- Jacobs, J. V. (2016). A review of stairway falls and stair negotiation: Lessons learned and future needs to reduce injury. *Gait and Posture, 49*, 159–167. <https://doi.org/10.1016/j.gaitpost.2016.06.030>
- Johnson, D. A., & Pauls, J. (2010). Systemic stair step geometry defects, increased injuries, and public health plus regulatory responses. *Contemporary Ergonomics and Human Factors*, 453–461. Retrieved from http://assets1.mytrainsite.com/501249/ergosoc__stf_papers.pdf
- Karamanidis, K., & Arampatzis, A. (2007). Age-related degeneration in leg-extensor muscle-tendon units decreases recovery performance after a forward fall: Compensation with running experience. *European Journal of Applied Physiology, 99*(1), 73–85. <https://doi.org/10.1007/s00421-006-0318-2>
- Kelsey, J. L., Procter-Gray, E., Hannan, M. T., & Li, W. (2012). Heterogeneity of falls among older adults: Implications for public health prevention. *American Journal of Public Health, 102*(11), 2149–2156. <https://doi.org/10.2105/AJPH.2012.300677>
- Keskin, D., Borman, P., Ersöz, M., Kurtaran, A., Bodur, H., & Akyüz, M. (2008). The Risk Factors Related to Falling in Elderly Females. *Geriatric Nursing, 29*(1), 58–63. <https://doi.org/10.1016/j.gerinurse.2007.06.001>
- Kim, B. J. (2009). Prevention of falls during stairway descent in older adults. *Applied Ergonomics, 40*(3), 348–352. <https://doi.org/10.1016/j.apergo.2008.11.012>
- King, S. L., Underdown, T., Reeves, N. D., Baltzopoulos, V., & Maganaris, C. N. (2018). Alternate stair descent strategies for reducing joint moment demands in older individuals. *Journal of Biomechanics, 78*, 126–133. <https://doi.org/10.1016/j.jbiomech.2018.07.029>
- King, S. L., Vanicek, N., & O'Brien, T. D. (2017). Sagittal plane joint kinetics during stair ascent in patients with peripheral arterial disease and intermittent claudication. *Gait and Posture, 55*, 81–86. <https://doi.org/10.1016/j.gaitpost.2017.03.029>
- Kunzler, M. R., Da Rocha, E. S., Dos Santos, C. S., Ceccon, F. G., Priario, L. A., & Carpes, F. P. (2018). Should we consider steps with variable height for a safer stair negotiation in older adults? *Work, 59*(1), 15–21. <https://doi.org/10.3233/WOR-172658>
- Laudanski, A., Brouwer, B., & Li, Q. (2013). Measurement of lower limb joint kinematics using inertial sensors during stair ascent and descent in healthy older adults and stroke survivors. *Journal of Healthcare Engineering, 4*(4), 555–576. <https://doi.org/10.1260/2040-2295.4.4.555>

- Lawrence, B. A., Spicer, R. S., & Miller, T. R. (2014). *A fresh look at the costs of non-fatal consumer product injuries*. 1–7. <https://doi.org/10.1136/injuryprev-2014-041220>
- McFadyen, B. J., & Winter, D. A. (1988). An integrated biomechanical analysis of normal stair ascent and descent. *Journal of Biomechanics*, *21*(9), 733–744. [https://doi.org/10.1016/0021-9290\(88\)90282-5](https://doi.org/10.1016/0021-9290(88)90282-5)
- Mian, O. S., Narici, M. V., Minetti, A. E., & Baltzopoulos, V. (2007). Centre of mass motion during stair negotiation in young and older men. *Gait and Posture*, *26*(3), 463–469. <https://doi.org/10.1016/j.gaitpost.2006.11.202>
- Mitchell, S. E., Aitken, S. A., & Court-Brown, C. M. (2013). The Epidemiology of Fractures Caused by Falls Down Stairs. *ISRN Epidemiology*, *2013*, 1–6. <https://doi.org/10.5402/2013/370340>
- Miyasike-Dasilva, V., Allard, F., & McIlroy, W. E. (2011). Where do we look when we walk on stairs? Gaze behaviour on stairs, transitions, and handrails. *Experimental Brain Research*, *209*(1), 73–83. <https://doi.org/10.1007/s00221-010-2520-z>
- Muhaidat, J., Kerr, A., Rafferty, D., Skelton, D. A., & Evans, J. J. (2011). Measuring foot placement and clearance during stair descent. *Gait and Posture*, *33*(3), 504–506. <https://doi.org/10.1016/j.gaitpost.2010.12.004>
- Nagata, H. (2014). Case study on possible falling patterns of a fatal fall from stairs. *Industrial Health*, *52*(5), 432–438. <https://doi.org/10.2486/indhealth.2014-0092>
- Nemire, K., Johnson, D. A., & Vidal, K. (2016). The science behind codes and standards for safe walkways: Changes in level, stairways, stair handrails and slip resistance. *Applied Ergonomics*, *52*, 309–316. <https://doi.org/10.1016/j.apergo.2015.07.021>
- NFPA 101. *NFPA 101 Life Safety Code*. , (2000).
- Nicol, S., Roys, M., Garrett, H., & BRE. (2011). *Briefing paper:the cost of poor housing to the NHS*. Watford, UK: BRE Trust.
- Novak, A. C., Komisar, V., Maki, B. E., & Fernie, G. R. (2016). Age-related differences in dynamic balance control during stair descent and effect of varying step geometry. *Applied Ergonomics*, *52*, 275–284. <https://doi.org/10.1016/j.apergo.2015.07.027>
- Ojha, H. A., Kern, R. W., Lin, C.-H. J., & Winstein, C. J. (2009). Age affects the attentional demands of stair ambulation: Evidence from a dual-task Approach. *Physical Therapy*, *89*(7), 643–652.
- Pataky, T. C. (2012). One-dimensional statistical parametric mapping in Python. *Computer Methods in Biomechanics and Biomedical Engineering*, *15*(3), 295–301. <https://doi.org/10.1080/10255842.2010.527837>
- Pauls, J. (2013). Relating stair nosing projection, tread run dimension, shoe geometry, descent biomechanics, user expectations, overstepping missteps, and closed-riser heel scuff missteps. *International Conference on Fall Prevention and Protection*, 115–120.
- Pauls, J., & Barkow, B. (2013). Combining Risks From Two Leading Factors in Stair-Related Falls. *International Conference on Fall Prevention and Protection 2013*, 87–92.
- Pauls, J., & Harbuck, S. C. (2008). Ergonomics-based Methods of Inspecting, Assessing and Documenting Environmental Sotes of Injurious Falls. *ASSE Professional Development Conference and Exhibition, 9-12 June, Las Vegas, Nevada*. Las Vegas, Nevada: American Society of Safety Engineers.

- Pijnappels, M., Reeves, N. D., Maganaris, C. N., & van Dieën, J. H. (2008). Tripping without falling; lower limb strength, a limitation for balance recovery and a target for training in the elderly. *Journal of Electromyography and Kinesiology*, *18*(2), 188–196. <https://doi.org/10.1016/j.jelekin.2007.06.004>
- Pijnappels, M., van der Burg, J. C. E., Reeves, N. D., & van Dieën, J. H. (2008). Identification of elderly fallers by muscle strength measures. *European Journal of Applied Physiology*, *102*(5), 585–592. <https://doi.org/10.1007/s00421-007-0613-6>
- Reeves, N. D., Spanjaard, M., Mohagheghi, A. A., Baltzopoulos, V., & Maganaris, C. N. (2008a). Influence of light handrail use on the biomechanics of stair negotiation in old age. *Gait and Posture*, *28*(2), 327–336. <https://doi.org/10.1016/j.gaitpost.2008.01.014>
- Reeves, N. D., Spanjaard, M., Mohagheghi, A. A., Baltzopoulos, V., & Maganaris, C. N. (2008b). The demands of stair descent relative to maximum capacities in elderly and young adults. *Journal of Electromyography and Kinesiology*, *18*(2), 218–227. <https://doi.org/10.1016/j.jelekin.2007.06.003>
- Reeves, N. D., Spanjaard, M., Mohagheghi, A. A., Baltzopoulos, V., & Maganaris, C. N. (2009). Older adults employ alternative strategies to operate within their maximum capabilities when ascending stairs. *Journal of Electromyography and Kinesiology*, *19*(2), e57–e68. <https://doi.org/10.1016/j.jelekin.2007.09.009>
- Reid, S. M., Lynn, S. K., Musselman, R. P., & Costigan, P. A. (2007). Knee biomechanics of alternate stair ambulation patterns. *Medicine and Science in Sports and Exercise*, *39*(11), 2005–2011. <https://doi.org/10.1249/mss.0b013e31814538c8>
- Reid, S. M., Novak, A. C., Brouwer, B., & Costigan, P. A. (2011). Relationship between stair ambulation with and without a handrail and centre of pressure velocities during stair ascent and descent. *Gait and Posture*, *34*(4), 529–532. <https://doi.org/10.1016/j.gaitpost.2011.07.008>
- Roys, M. (2001). Serious stair injuries can be prevented by improved stair design. *Applied Ergonomics*, *32*(2), 135–139. [https://doi.org/10.1016/S0003-6870\(00\)00049-1](https://doi.org/10.1016/S0003-6870(00)00049-1)
- Roys, M. (2013). *Refurbishing stairs in dwellings to reduce the risk of fall and injuries*. Watford, UK: IHS BRE Press.
- Roys, M., & Wright, M. (2005). Minor variations in gait and their effect on stair safety. In Phillip D. Bust & P. T. McCabe (Eds.), *conference on Contemporary Ergonomics (CE 2005)* (pp. 427–431). Hatfield, UK: McCabe CRC press.
- Selvaraj, M., Baltzopoulos, V., Shaw, A., Maganaris, C. N., Cullen, J., O'Brien, T., & Kot, P. (2019). Stair fall risk detection using wearable sensors. *Proceedings - International Conference on Developments in ESystems Engineering, DeSE, 2018-Septe*, 108–112. <https://doi.org/10.1109/DeSE.2018.00023>
- Shaw, R. (2015). Preventing Falls – Learning From Design-Related Issues in Care Homes. In K. Christer (Ed.), *3rd European Conference on Design4Health* (pp. 1–10). Sheffield.
- Spanjaard, M., Reeves, N. D., van Dieën, J. H., Baltzopoulos, V., & Maganaris, C. N. (2008a). Influence of step-height and body mass on gastrocnemius muscle fascicle behavior during stair ascent. *Journal of Biomechanics*, *41*(5), 937–944. <https://doi.org/10.1016/j.jbiomech.2008.01.003>
- Spanjaard, M., Reeves, N. D., van Dieën, J. H., Baltzopoulos, V., & Maganaris, C. N. (2008b). Lower-limb biomechanics during stair descent: influence of step-height and body mass.

- Journal of Experimental Biology*, 211(9), 1368–1375. <https://doi.org/10.1242/jeb.014589>
- Spanjaard, M., Reeves, N. D., Van Dieën, J. H., Baltzopoulos, V., & Maganaris, C. N. (2007). Gastrocnemius muscle fascicle behavior during stair negotiation in humans. *Journal of Applied Physiology*, 102(4), 1618–1623. <https://doi.org/10.1152/jappphysiol.00353.2006>
- Startzell, J. K. M. S., Owens, D. A. P., Mulfinger, L. M. P., & Cavanagh, P. R. P. (2000). Stair Negotiation in Older People: A Review. [Miscellaneous Article]. *American Geriatrics Society*, 48(1), 267–580.
- Stessman, J., Rottenberg, Y., & Jacobs, J. M. (2017). Climbing stairs, handrail use, and survival. *Journal of Nutrition, Health and Aging*, 21(2), 195–201. <https://doi.org/10.1007/s12603-016-0763-5>
- Telonio, A., Blanchet, S., Maganaris, C. N., Baltzopoulos, V., & McFadyen, B. J. (2013). The detailed measurement of foot clearance by young adults during stair descent. *Journal of Biomechanics*, 46(7), 1400–1402. <https://doi.org/10.1016/j.jbiomech.2013.02.013>
- Templer, J. (1992). *The staircase: studies of hazards, falls and safer design*. Cambridge, MA: The MIT Press.
- Templer, J., Mullet, G. M., Archea, J., & Margulis, S. T. (1978). *An analysis of the behavior of stair users*. <https://doi.org/10.6028/NBS.IR.78-1554>
- Thomas, N. M., Skervin, T., Foster, R. J., O'Brien, T. D., Carpenter, M. G., Maganaris, C. N., ... Hollands, M. A. (2020). Optimal lighting levels for stair safety: Influence of lightbulb type and brightness on confidence, dynamic balance and stepping characteristics. *Experimental Gerontology*, 132(January), 110839. <https://doi.org/10.1016/j.exger.2020.110839>
- Tiedemann, A. C., Sherrington, C., & Lord, S. R. (2007). Physical and psychological factors associated with stair negotiation performance in older people. *Journals of Gerontology - Series A Biological Sciences and Medical Sciences*, 62(11), 1259–1265. <https://doi.org/10.1093/gerona/62.11.1259>
- Timmis, M. A., Bennett, S. J., & Buckley, J. G. (2009). Visuomotor control of step descent: Evidence of specialised role of the lower visual field. *Experimental Brain Research*, 195(2), 219–227. <https://doi.org/10.1007/s00221-009-1773-x>
- Vallabhajosula, S., Tan, C. W., Mukherjee, M., Davidson, A. J., & Stergiou, N. (2015). Biomechanical analyses of stair-climbing while dual-tasking. *Journal of Biomechanics*, 48(6), 921–929. <https://doi.org/10.1016/j.jbiomech.2015.02.024>
- Weerdesteyn, V., Hollands, K. L., & Hollands, M. A. (2018). Gait adaptability. In *Handbook of Clinical Neurology* (1st ed., Vol. 159). <https://doi.org/10.1016/B978-0-444-63916-5.00008-2>
- Winter, D. A. (1995). Human balance and posture control during standing and walking. *Gait and Posture*, Vol. 3, pp. 193–214. [https://doi.org/10.1016/0966-6362\(96\)82849-9](https://doi.org/10.1016/0966-6362(96)82849-9)
- Wright, M., & Roys, M. (2005). Effect of changing stair dimensions on safety. *Annual Conference, Ergonomics: Contemporary Ergonomics 2005*, 469–474. Hatfield, UK: Ergonomics Society.
- Wright, M., & Roys, M. (2008). Accidents on English dwelling stairs are directly related to going size. In Paul D. Bust (Ed.), *Annual conference of the ergonomics society 2008* (pp. 632–637). Retrieved from

http://ssu.ac.ir/cms/fileadmin/user_upload/Moavenatha/MBehdashti/TebKar/PDFs/Contemporary_Ergonomics_2008.pdf#page=651

Zachazewski, J. E., Riley, P. O., & Krebs, D. E. (1993). Biomechanical analysis of body mass transfer during stair ascent and descent of healthy subjects. *Journal of Rehabilitation Research and Development*, 30(4), 412–422.

Zietz, D., & Hollands, M. (2009). Gaze behavior of young and older adults during stair walking. *Journal of Motor Behavior*, 41(4), 357–365. <https://doi.org/10.3200/JMBR.41.4.357-366>

Zietz, D., Johannsen, L., & Hollands, M. (2011). Stepping characteristics and Centre of Mass control during stair descent: Effects of age, fall risk and visual factors. *Gait and Posture*, 34(2), 279–284. <https://doi.org/10.1016/j.gaitpost.2011.05.017>