



## LJMU Research Online

**Bossuyt, FM, García-Pinillos, F, Raja Azidin, RM, Vanrenterghem, J and Robinson, MA**

**The Utility of a High-intensity Exercise Protocol to Prospectively Assess ACL Injury Risk.**

<http://researchonline.ljmu.ac.uk/id/eprint/2473/>

### Article

**Citation** (please note it is advisable to refer to the publisher's version if you intend to cite from this work)

**Bossuyt, FM, García-Pinillos, F, Raja Azidin, RM, Vanrenterghem, J and Robinson, MA (2015) The Utility of a High-intensity Exercise Protocol to Prospectively Assess ACL Injury Risk. International Journal of Sports Medicine. ISSN 0172-4622**

LJMU has developed [LJMU Research Online](#) for users to access the research output of the University more effectively. Copyright © and Moral Rights for the papers on this site are retained by the individual authors and/or other copyright owners. Users may download and/or print one copy of any article(s) in LJMU Research Online to facilitate their private study or for non-commercial research. You may not engage in further distribution of the material or use it for any profit-making activities or any commercial gain.

The version presented here may differ from the published version or from the version of the record. Please see the repository URL above for details on accessing the published version and note that access may require a subscription.

For more information please contact [researchonline@ljmu.ac.uk](mailto:researchonline@ljmu.ac.uk)

<http://researchonline.ljmu.ac.uk/>

# The utility of a high-intensity exercise protocol to prospectively assess ACL injury risk

Fransiska M. Bossuyt<sup>1</sup>, Felipe García-Pinillos<sup>2</sup>, Raja M.F. Raja Azidin<sup>1</sup>, Jos Vanrenterghem<sup>1</sup>,  
Mark A. Robinson<sup>1</sup>

<sup>1</sup>Research Institute for Sport and Exercise Sciences, Liverpool John Moores University, Liverpool, United Kingdom

<sup>2</sup>Department of Corporal Expression, University of Jaen, Jaen, Spain

International Journal of Sports Medicine

<http://dx.doi.org/10.1055/s-0035-1555930>

## **Abstract**

This study investigated the utility of a 5-min high-intensity exercise protocol (SAFT5) to include in prospective cohort studies investigating ACL injury risk. 15 active females were tested on 2 occasions during which their non-dominant leg was analysed before SAFT5 (PRE), immediately after (POST0), 15 min after (POST15), and 30 min after (POST30). On the first occasion, testing included 5 maximum isokinetic contractions for eccentric and concentric hamstring and concentric quadriceps and on the second occasion, 3 trials of 2 landing tasks (i.e. single-leg hop and drop vertical jump) were conducted. Results showed a reduced eccentric hamstring peak torque at POST0, POST15 and POST30 ( $p < .05$ ) and a reduced functional HQ ratio (Hecc/Qcon) at POST15 and POST30 ( $p < .05$ ). Additionally, a more extended knee angle at POST30 ( $p < .05$ ) and increased knee internal rotation angle at POST0 and POST15 ( $p < .05$ ) were found in a single-leg hop. SAFT5 altered landing strategies associated with increased ACL injury risk and similar to observations from match simulations. Our findings therefore support the utility of a high-intensity exercise protocol such as SAFT5 to strengthen injury screening tests and to include in prospective cohort studies where time constraints apply.

Corresponding Author:

Fransiska Marie Bossuyt : [fransiskabossuyt@gmail.com](mailto:fransiskabossuyt@gmail.com)

## INTRODUCTION

Risk factors of ACL injuries can only be defined with the highest level of evidence when prospectively assessed.[39] Muscular and biomechanical ACL injury risk factors have been studied extensively as they are modifiable through training.[41] Muscular risk factors include reduced eccentric hamstring peak torque ( $H_{ecc}$ ) and reduced hamstring/quadriceps ratio ( $H/Q$ ).[45] Reduced hamstring strength is believed to permit increased anterior tibial translation and in turn increase ACL strain.[2] Biomechanical risk factors include increased peak knee abduction moment and peak vertical ground reaction force ( $VGRF_{peak}$ ).[21] Reduced knee flexion at initial contact (IC) during landing has been associated with increased anterior tibial translation[6, 7] which causes increased ACL loading.[6, 8, 9] Additionally, increased knee internal rotation has been associated with increased ACL loading.[9, 10] It is important to note that fatigue (i.e., loss of maximum or potential performance) alters these factors which may further increase injury risk.[11, 12] Additionally, evidence shows that most injuries occur at the end of a soccer match.[12, 13] These findings suggest that fatigue plays a crucial role on muscular and biomechanical risk factors in the mechanism of ACL injury.[19] To date, however, no prospective studies have included exercise-induced fatigue in their screening protocols, most likely due to the conflict between screening a large cohort and the time-consuming nature of inducing fatigue.

Fatigue has been induced in a number of ways, some of which are more related to dynamic activities than others. Previous research has suggested, however, that including functional movements as part of the protocol is key to revealing specific match-play-induced deficits which can increase ACL injury risk.[14, 15] As such the effects of a shuttle run revealed changes in transverse plane kinematics in sidestep cutting as increased external rotation of hip, knee and ankle angle at IC and increased knee internal rotation angle during stance.[40] In another study, a treadmill-based soccer match simulation reduced  $H/Q$ . [16] Finally, a soccer specific match simulation (SAFT<sup>90</sup>) which included multidirectional movements, high accelerations and decelerations, and which was shown to be a valid simulation of match play[26], caused significant reductions in  $H_{ecc}$  and in  $H/Q$ . [36,43,44] Fatigue induced by soccer match play (90 min) has been suggested to be a combination of both central (altered motor commands from the motor cortex) and peripheral fatigue (metabolite accumulation, limitations in energy supply, reduced blood flow and neuromuscular mechanisms)[37,50]. Additionally it has been suggested that during soccer, players experience fatigue in several different ways: (1) disturbed muscle ion homeostasis during temporary fatigue after short bursts of high-intensity

exercises, (2) lowered muscle temperature (e.g., at the beginning of the second half) and (3) through muscle glycogen and dehydration as experienced towards the end of a game.[32]

Whilst full-length match simulations would be considered most ideal for simulating the effects of match play, the development and evaluation of short-term protocols is needed to include match-play-induced fatigue assessment within prospective studies. It is important to acknowledge the influence of intensity, duration and type of contraction on the mechanisms of fatigue.[3] As far as we are aware however, no previous study has directly compared neuromuscular responses between short-term protocols and full-length match simulations. Nevertheless, previous findings [27] found similar biomechanical alterations in response to a short-duration high-intensity protocol and a longer duration protocol (30min). 2 studies involving short-term protocols, the first including vertical jumps followed by 30-m sprint, and the second including series of athletic exercises (countermovement jump (CMJ), step up/down, squat and shuttle run), resulted in decreased knee flexion angles at IC and increased knee abduction moments in sidestep cutting[10] and stop-jump tasks.[8] Finally, a short-term protocol based on continuous drills (step up/down and plyometric bounding) caused increased knee abduction angles/moments and increased knee internal rotation angles in a drop vertical jump (DVJ).[31] It is important to note that all these protocols induced fatigue until maximum exhaustion which is not representative of match play, and inappropriate for the inclusion in prospective studies as this implies differences in duration or amount of repetitions.

Few if any studies have focused on short-term protocols that simulate match play of dynamic sports (i.e., sport which involves high accelerations and decelerations and typically involves interactions with an object (ball, racket, etc.)). Therefore, the aim of this study was to investigate how a short-term high-intensity exercise protocol (SAFT<sup>5</sup>), based on a long-duration match-play simulation (SAFT<sup>90</sup>) [26], affects muscular and biomechanical markers of ACL injury in recreationally active females. It was hypothesized that SAFT<sup>5</sup> would result in changes in markers of ACL injury risk.

## **METHODS**

### **Participants**

15 females (age:  $22\pm 3$  years, height:  $1.68\pm 0.07$  m, mass:  $70.8\pm 8.9$  kg) were tested following a sample-size estimation from a functional fatigue protocol to observe a  $5^\circ$  difference in knee flexion angle at 80 % statistical power and  $\alpha=0.05$ . [11,31] All participants met the inclusion criteria: (1) female, (2) recreationally active (i.e., 3 sessions per week) in dynamic sports (hockey, netball, etc.), (3) did not suffer from an ACL injury and (4) did not suffer from any other lower limb injury within the last 6 months before data collection. Ethical approval was granted by the university ethics committee and all participants provided informed consent according to IJSM ethical standards. [18]

### **Design**

This was a cross-sectional study with a repeated measures design. Initially participants were familiarized with the protocol and assessment methods, height and weight were recorded, and maximum jump height ( $\text{JumpHeight}_{\text{max}}$ ) was defined. This was followed by 2 testing sessions which were separated by at least 3 days. Both sessions included a dynamic warm-up, the SAFT<sup>5</sup> protocol, a pre-test (PRE), a test immediately following SAFT<sup>5</sup> (POST0), after 15 min of passive rest (POST15) and after 30 min of passive rest (POST30). These moments in time were selected in order to define the prolonged effect of SAFT<sup>5</sup>. This information is required for the inclusion of SAFT<sup>5</sup> in a prospective study protocol which could consist of measurements before and after SAFT<sup>5</sup>. In addition, this information would be useful for the design of activity-rest cycles to minimize the potential for fatigue-related injury. Different parameters were assessed during each session and between participants the order of sessions was randomly assigned. Participants were instructed to avoid strenuous exercises 48 hours prior to testing.

### **Exercise protocol**

SAFT<sup>5</sup> is based on the first five min of SAFT<sup>90</sup>. [26,36] The distance of the SAFT<sup>90</sup> protocol was modified to 15m in order to make the SAFT<sup>5</sup> course feasible in our laboratory (Figure 1 and Table 1). The intensity of SAFT<sup>5</sup> was increased by adding high-intensity exercises, based on previous studies [11,31,51] and pilot work [9,54]. Pilot work aimed at defining the activity profile of the protocol by investigating the implementation of functional

high-intensity movements. Several variations of the protocol based on different high-intensity exercises, amount of repetitions and order of exercises were explored by monitoring HR and RPE during the protocol which represented the intensity. The final protocol was selected in accordance to the following criteria: (1) HR and RPE presented a similar overall pattern as during SAFT<sup>90</sup> and actual game play [24,36], and (2) practical and personal observations of the researchers. As such it was decided to include the following 3 exercises: a CMJ at 80% of their  $\text{JumpHeight}_{\text{max}}$ , an agility ladder drill (one foot per square) and a ‘jump scissors’ task (jumping from unilateral lunge with left leg forward and hands placed on the hips, to unilateral lunge with right leg forward)(Table 1). During the protocol, white tape was placed onto a wall which represented 80%  $\text{JumpHeight}_{\text{max}}$ , participants had to touch the white tape during every jump and received verbal feedback if they didn’t reach the tape.

### **Data collection**

At one test session maximum voluntary contractions (MVCs) of concentric hamstring strength ( $H_{\text{con}}$ ), concentric quadriceps strength ( $Q_{\text{con}}$ ) and  $H_{\text{ecc}}$  were assessed by an isokinetic dynamometer (IKD, Biodex System 3, Shirley, NY). The non-dominant leg (i.e., non-preferred leg to kick a ball with) was tested as it has been identified as the most vulnerable to ACL injury in females.[6,38] Concentric MVCs consisted of repeated knee flexion and extension contractions within 90° RoM at 120°/s. During eccentric MVCs, participants resisted against the passive external knee extension moment of the IKD over 90° RoM and at 120°/s.[35, 43]Participants were verbally encouraged and 5 repetitions were measured for each task with one min rest between different contractions. The order of assessment was randomly assigned.

At the other test session, participants wore tight-fitting clothes and measurements consisted of 3D motion and force analysis of DVJ and single-leg hop (SLH). For the DVJ, participants were instructed to drop off a 30-cm high box (feet 20 cm apart), and land with each foot on separate force platforms, immediately rebounding for a maximum vertical jump. For the SLH, participants were instructed to stand on the non-dominant leg and hop forward to cover a distance of 75% of body height [33] in order to use a standardised distance adjusted to personal dimensions. 3 successful trials of each task were recorded with trials excluded if the participant lost balance less than 2s after landing.

10 optoelectronic cameras sampling at 250 Hz (OQUS 3, Qualysis AB, Gothenburg, Sweden) were used to collect 3D motion data. Spherical reflective markers were attached to lower limb and trunk according to the LJMU kinematic model [49], which has established

reliability.[28] One static and 4 functional motion trials were recorded to define functional hip and knee joint axes, after which anatomy-defining markers were removed. GRF were collected simultaneously from 2 force platforms at 1500 Hz (Kistler, Winterthur, Switzerland).

Additional measurements for both sessions, recorded every 5 min throughout the sessions, and during SAFT<sup>5</sup>, included JumpHeight<sub>max</sub> with a jump mat (Probotics, Inc., Huntsville, AL) in order to assess fatigue as a reduction of performance, heart rate (HR) (Polar heart rate system, Electro, Finland) and rate of perceived exertion (RPE) (20-point Borg scale). Timing and order of each measurement is represented in Table 2.

## Data analysis

Kinematic and kinetic data were calculated within Visual 3D (C-Motion, Germantown, MD). Marker trajectories and forces were filtered through a Butterworth and a critically damped low-pass filter with 20-Hz cut-off frequencies and normalized to 101 time nodes. IC and take-off were defined as the instant when GRF exceeded or reached below 10N.[10] The stance phase of an SLH was defined as one second after IC. Only the first landing of the DVJ was used for analysis.[1] Euler rotations (X-Y-Z) were used for joint angle calculations and knee moments were obtained by inverse dynamics [31] and are reported as external moments. IKD data were gravity-corrected and analysed with a custom Matlab (MathWorks, Inc., Natick, MA, USA) program. Peak torques were calculated from a polynomial fit of data points that met the criteria within a 10% tolerance (velocity: 120°/s, RoM at least 70° for H<sub>con</sub> and Q<sub>con</sub>, and RoM at least 50° for H<sub>ecc</sub>). Finally, the functional HQ ratio (H<sub>ecc</sub>/Q<sub>con</sub>) which was previously presented as a valid representation of muscle-specific exertion induced by football match-play [12] and conventional HQ ratio (H<sub>con</sub>/Q<sub>con</sub>) were calculated. Dependent variables of interest were JumpHeight<sub>max</sub>, HR, RPE, H<sub>ecc</sub>/Q<sub>con</sub>, H<sub>con</sub>/Q<sub>con</sub>, H<sub>con</sub>, H<sub>ecc</sub> and Q<sub>con</sub>, knee flexion angle and transverse plane knee angle at IC, peak knee abduction moment and VGRF<sub>peak</sub>.

## Statistical treatment

Data are presented as means ± standard deviation. One-way repeated measures ANOVAs were used to assess meaningful variations across time for each variable. Percentage differences of jump height, H<sub>ecc</sub>, H<sub>con</sub>, Q<sub>con</sub>, H<sub>ecc</sub>/Q<sub>con</sub> and H<sub>con</sub>/Q<sub>con</sub> were calculated and HR was presented as a percentage of the estimated maximum HR (HR<sub>max</sub>=220-age). If statistical significance was found, pairwise comparisons were applied with Bonferroni corrections to reduce the risk of type-1 errors. Reliability of the 2 testing sessions was confirmed by (1) low

typical error and limits of agreement for RPE (Pre: 1, [-2;-1]; During: 1 [-1;1]; Post: 1 [-1;0]) and HR (Pre: 5 beats/min [-5;3]; During: 2 beats/min [1;4]; Post: 3 beats/min [-5;-1]) and (2) uniform errors based on observed homoscedasticity. All statistical analyses were performed in SPSS (Version 21.0, Chicago, IL) ( $\alpha=0.05$ ).

## RESULTS

There was a significant effect of SAFT<sup>5</sup> on HR ( $F_{3.99,47.88} = 257.78, p < 0.001$ ) and RPE ( $F_{3.66, 43.90} = 140.48, p < 0.001$ ) as these variables significantly increased up to  $89 \pm 4$  % HR<sub>max</sub> and 17 RPE during SAFT<sup>5</sup> ( $p < 0.001$ ) and up to 60 % HR<sub>max</sub> and 11 RPE five min post-SAFT<sup>5</sup> ( $p < 0.001$ ).

JumpHeight<sub>max</sub> significantly reduced ( $F_{3.41,47.80} = 39.33, p < 0.001$ ) (Figure 2) with a reduction during SAFT<sup>5</sup> by  $5.8 \pm 2.0$  cm (15%,  $p < 0.05$ ) and after 20 and 30 min passive rest by  $1.9 \pm 0.1$  cm (5%) ( $p = 0.019$  and  $p = 0.011$ ).

A significant main effect of SAFT<sup>5</sup> on H<sub>ecc</sub> was found ( $F_{2.27, 38.29} = 11.01, p < 0.001$ ) (Figure 3) with a significant reduction at POST0 (7%,  $p = 0.029$ ), POST15 (13 %,  $p < 0.001$ ) and POST30 (18%,  $p < 0.001$ ) compared to PRE, and at POST30 compared to POST0 (12%,  $p = 0.024$ ). This caused a significant main effect in the H<sub>ecc</sub>/Q<sub>con</sub> ( $F_{2.01, 28.14} = 4.27, p = 0.024$ ). There was no significant reduction in the H<sub>ecc</sub>/Q<sub>con</sub> immediately post-SAFT<sup>5</sup>, however, POST15 and POST30 showed a significant reduction of 9% ( $p = 0.010$ ) and 13 % ( $p = 0.003$ ).

There was no significant effect of SAFT<sup>5</sup> on H<sub>con</sub>/Q<sub>con</sub> ( $F_{2.93,41.01} = .63; p = 0.566$ ). Even though there was a significant effect of SAFT<sup>5</sup> on both H<sub>con</sub> ( $F_{2.82,39.42} = 3.91, p = 0.025$ ) and Q<sub>con</sub> ( $F_{1.83,25.66} = 3.70, p = 0.042$ ) there was only a significant reduction between PRE and POST30 in H<sub>con</sub> (7 %,  $p = 0.014$ ) and Q<sub>con</sub> (5 %,  $p = 0.024$ ), and between POST0 and POST30 in H<sub>con</sub> (6 %,  $p = 0.013$ ) and Q<sub>con</sub> (4 %,  $p = 0.045$ ).

Results of the SLH indicated that SAFT<sup>5</sup> induced (1) a significantly increased VGRF<sub>peak</sub> between PRE and POST15, POST30 and between POST0 and POST15, POST30, (2) a significantly more extended knee ( $2.2 \pm 2.6$  °) between PRE and POST30 and (3) a significantly increased internal rotation angle between PRE and POST0 ( $4.1 \pm 4.5$  °) and POST15 ( $4.5 \pm 3.8$  °) (Table 3). No significant effect of SAFT<sup>5</sup> was found on peak knee-abduction moment in SLH and on any of dependent variables in DVJ. Supplementary files include kinematics and kinetics of an SLH (Appendix 1 and 2).



## DISCUSSION

This study determined whether the SAFT<sup>5</sup>, a high-intensity exercise protocol, could be affectively used to induce changes in the muscular and biomechanical characteristics that are typically associated to ACL injury risk. The results partly confirmed the hypothesis. Most notably, there was a significant reduction in  $H_{ecc}$  and  $H_{ecc}/Q_{con}$ , and altered landing strategies in SLH. The protocol caused a 15% drop in jump performance and RPE was rated between ‘hard’ and ‘very hard’ with the average HR ( $89 \pm 4\%$   $HR_{max}$ ) similar to that of female football match play ( $87-97\%$   $HR_{max}$ [24]). The intensity of the current protocol therefore appears to induce physiological responses similar to those in longer duration match-play situations. In general, current findings imply the importance of screening athletes after a high-intensity functional exercise protocol such as SAFT<sup>5</sup>.

The significant reduction in  $H_{ecc}$  immediately after SAFT<sup>5</sup> and POST15 is in agreement with previous studies investigating the effect of a soccer-specific field test over 90 min (SAFT<sup>90</sup>).[17, 43] The selective occurrence of fatigue in  $H_{ecc}$  has been explained previously by the presence of more fatigable type-2 muscle fibres [14], and the high eccentric requirements of the hamstrings in repetitive sprinting and kicking [53] to counteract the anterior shear forces created by the quadriceps. Despite the significant reduction in  $H_{ecc}$  between PRE and every post-test,  $H_{ecc}/Q_{con}$  was only significantly reduced POST15 and POST30.[17, 43] It should be especially noted that at POST30,  $H_{ecc}/Q_{con}$  fell below the at-risk threshold of 0.71.[52] The delayed reduction of  $H_{ecc}/Q_{con}$  can be explained by the short-term high-intensity characteristics of SAFT<sup>5</sup>. Firstly, the occurrence of post activation potentiation (PAP) (i.e., improved muscular performance in response to conditioning stimulus [22]) could have interfered with the effects immediately following SAFT<sup>5</sup>, as previous work has found an improvement in peak force within the first 5 min following exercise.[46]  $H_{ecc}/Q_{con}$  is, however, not increased post-SAFT<sup>5</sup> which assumes that PAP is not the main contributor. Secondly, it could be suggested that there is a delay in peripheral fatigue (i.e., fatigue occurred within the muscle itself) immediately post-SAFT<sup>5</sup> as a recent study concluded that central fatigue (i.e., alterations in the nervous system) manifests prior to reductions in knee-flexor maximal torque in response to SAFT<sup>90</sup>. [30] This finding was explained by the earlier and more pronounced effect of central fatigue on explosive force-producing exercises. The delayed onset of peripheral fatigue is represented in the significant reduction in  $H_{ecc}/Q_{con}$  after 15 min passive rest and is in agreement with previous research.[17, 26, 43] There was no significant reduction in  $H_{con}/Q_{con}$  post-SAFT<sup>5</sup> which further supports the use of  $H_{ecc}/Q_{con}$  for the evaluation of hamstrings function during dynamic

activities. Based on  $H_{ecc}$  and HQ ratios, it could be assumed that SAFT<sup>5</sup> induces detrimental effects on muscle performance similar to changes after match-play exertion as SAFT<sup>90</sup>. Detrimental effects are, however, best observed with a 15 min delay.

In accordance with the hypothesis, SAFT<sup>5</sup> altered landing strategies in the non-dominant leg of an SLH. The reduced knee-flexion angle and increased knee internal rotation are in accordance with other studies exploring the effect of a short-term fatigue protocol on sidestep and stop-jump tasks.[8,10,11] The significant increase in  $VGRF_{peak}$  post-SAFT<sup>5</sup> is in contrast with a previous study investigating the effect of a short-term fatigue protocol.[11] It should be noted that SAFT<sup>5</sup> aimed to replicate match-play exertion and deviated from the mentioned short-term protocols by the lack of maximum exhaustion which increases the stress applied on the body and may cause greater detrimental effects on landing strategies. Several possible speculations could relate to the significantly reduced knee-flexion angle only after 30 minutes passive rest: (1) the suggested relationship between exercise-related changes in fatigue (e.g. decreased landing forces) and knee laxity (e.g., greater knee-extensor loads and knee shear forces), which is dependent on the baseline knee laxity [42], (2) altered muscular activation patterns in response to fatigue as reduced pre-activation of the hamstrings and gastrocnemius could affect the sagittal and transverse plane differently [15] and (3) post-activation potentiation, as described previously, could play a role [46]. Further studies, which take these variables into account, will need to be undertaken. Maximum exhaustion may alter landing strategies which are more related to reduced power generation than to altered stabilization mechanisms. This may explain the different findings of the  $VGRF_{peak}$ . Previous studies found increased peak knee internal rotation post-fatigue [5,31,40,47] but to date, no study reported increased knee internal rotation at IC during an SLH. Nevertheless, an extended knee position at IC during landing has been associated with increased ACL loading especially during single-leg landing.[25] Additionally, increased internal rotation of the tibia [13,29] and increased  $VGRF_{peak}$  [7] have been associated with increased ACL loading. In summary, SAFT<sup>5</sup> induced kinematic changes in landing strategies of an SLH which are thought to be associated with increased ACL injury risk. This evidence is in support of the notion that biomechanical screening after a functional exercise protocol such as SAFT<sup>5</sup> may be better suited to identify at-risk individuals than observations without prior high-intensity functional exercises. This was evident in an SLH and not in a bilateral DVJ.

Several limitations to the present study need to be acknowledged. Firstly, due to short-term characteristics of SAFT<sup>5</sup>, different physiological processes will be triggered compared to

long-duration match play. More specifically, high-intensity exercises (5 min) induce accumulation of metabolites and ions resulting in metabolic acidosis [48], whereas long-duration exercises impose a greater aerobic demand and may deplete energy supply and cause dehydration.[24] This results in different loading on the body. Secondly, as training status was reported to influence fatigue-induced mechanisms [4], findings of the present study investigating recreational active athletes cannot be generalised to elite athletes. Athletes with a higher percentage of type-1 fibres (i.e., slow/fatigue resistant fibres) and a higher aerobic fitness are suggested to have, for instance, a greater capability of resisting fatigue.[4] Finally, whilst our study involved a closer simulation of match play than maximal exhaustion protocols may do, its findings do not directly pertain to the effects of actual match play.

The present study was designed to determine the effect of SAFT<sup>5</sup> on muscular and biomechanical markers of ACL injury risk, primarily to inform the development of future prospective studies that aim at including screening after functional exercises. SAFT<sup>5</sup> reduced  $H_{ecc}$  and  $H_{ecc}/Q_{con}$ , and caused altered landing patterns in SLH. All of the above have previously been associated with increased ACL injury risk and suggest that testing after a high-intensity functional exercise protocol such as SAFT<sup>5</sup> may strengthen the identification of individuals with increased ACL injury risk within a sporting population.

## REFERENCES

- <sup>1</sup> *Bates N a, Ford KR, Myer GD, Hewett TE.* Timing differences in the generation of ground reaction forces between the initial and secondary landing phases of the drop vertical jump. *Clin Biomech (Bristol, Avon)* 2013; 28: 796–799
- <sup>2</sup> *Behrens M, Mau-Moeller A, Wassermann F, Bruhn S.* Effect of fatigue on hamstring reflex responses and posterior-anterior tibial translation in men and women. *PLoS One* 2013; 8: e56988
- <sup>3</sup> *Bishop DJ.* Fatigue during intermittent-sprint exercise. *Clin Exp Pharmacol Physiol* 2012; 39: 836–841
- <sup>4</sup> *Bogdanis GC.* Effects of physical activity and inactivity on muscle fatigue. *Front Physiol* 2012; 3: 1–15
- <sup>5</sup> *Borotikar BS, Newcomer R, Koppes R, McLean SG.* Combined effects of fatigue and decision making on female lower limb landing postures: central and peripheral contributions to ACL injury risk. *Clin Biomech* 2008; 23: 81–92
- <sup>6</sup> *Brophy R, Silvers HJ, Gonzales T, Mandelbaum BR.* Gender influences: the role of leg dominance in ACL injury among soccer players. *Br J Sports Med* 2010; 44: 694–897
- <sup>7</sup> *Cerulli G, Benoit DL, Lamontagne M, Caraffa A, Liti A.* In vivo anterior cruciate ligament strain behaviour during a rapid deceleration movement: case report. *Knee Surgery, Sport Traumatol Arthrosc* 2003; 11: 307–311
- <sup>8</sup> *Chappell JD, Herman DC, Knight BS, Kirkendall DT, Garrett WE, Yu B.* Effect of fatigue on knee kinetics and kinematics in stop-jump tasks. *Am J Sports Med* 2005; 33: 1022–1029
- <sup>9</sup> *Chavez A, Knudson D, Harter ROD.* Activity-Specific Effects of Fatigue Protocols May Influence Landing Kinematics : A Pilot Study. *Int J Exerc Sci* 2013; 6: 242–249
- <sup>10</sup> *Cortes N, Greska E, Kollock R, Ambegaonkar J, Onate J a.* Changes in lower extremity biomechanics due to a short-term fatigue protocol. *J Athl Train* 2013; 48: 306–313
- <sup>11</sup> *Cortes N, Quammen D, Lucci S, Greska E, Onate J.* A functional agility short-term fatigue protocol changes lower extremity mechanics. *J Sports Sci* 2012; 30: 797–805
- <sup>12</sup> *Delextrat a, Gregory J, Cohen D.* The use of the functional H:Q ratio to assess fatigue in soccer. *Int J Sports Med* 2010; 31: 192–197
- <sup>13</sup> *Fleming BC, Renstrom PA, Beynnon BD, Engstrom B, Peura GD, Badger GJ, Johnson RJ.* The effect of weightbearing and external loading on anterior cruciate ligament strain. *J Biomech* 2001; 34: 163–170
- <sup>14</sup> *Garrett WE, Califf JC, Bassett FH.* Histochemical correlates of hamstring injuries. *Am J Sports Med* 1984; 12: 98–103
- <sup>15</sup> *Gehring D, Melnyk M, Gollhofer A.* Gender and fatigue have influence on knee joint control strategies during landing. *Clin Biomech (Bristol, Avon)* 2009; 24: 82–87

- 16 *Greco CC, Da Silva WL, Camarda SRA, Denadai BS.* Fatigue and rapid hamstring/quadriceps force capacity in professional soccer players. *Clin Physiol Funct Imaging* 2013; 33: 18–23
- 17 *Greig M.* The influence of soccer-specific fatigue on peak isokinetic torque production of the knee flexors and extensors. *Am J Sports Med* 2008; 36: 1403–1409
- 18 *Harriss DJ, Atkinson G.* Ethical standards in sports and exercise science research: 2014 update. *Int J Sports Med* 2013; 34: 1025–1028
- 19 *Hashemi J, Breighner R, Chandrashekar N, Hardy DM, Chaudhari AM, Shultz SJ, Slauterbeck JR, Beynnon BD.* Hip extension, knee flexion paradox: a new mechanism for non-contact ACL injury. *J Biomech* 2011; 44: 577–585
- 20 *Hawkins RD, Hulse MA, Wilkinson C, Hodson A, Gibson M.* The association football medical research programme: an audit of injuries in professional football. *Br J Sports Med* 2001; 35: 43–47
- 21 *Hewett TE, Myer GD, Ford KR, Heidt RS, Colosimo AJ, McLean SG, van den Bogert AJ, Paterno M V, Succop P.* Biomechanical measures of neuromuscular control and valgus loading of the knee predict anterior cruciate ligament injury risk in female athletes: a prospective study. *Am J Sports Med* 2005; 33: 492–501
- 22 *Hodgson M, Docherty D, Robbins D.* Post-Activation Potentiation. *Sports Med* 2005; 35: 585–596
- 23 *Hughes G, Watkins J.* A risk-factor model for anterior cruciate ligament injury. *Sports Med* 2006; 36: 411–428
- 24 *Krustrup P, Mohr M, Ellingsgaard H, Bangsbo J.* Physical Demands during an Elite Female Soccer Game: Importance of Training Status. *Med Sci Sport Exerc* 2005; 37: 1242–1248
- 25 *Laughlin WA, Weinhandl JT, Kernozek TW, Cobb SC, Keenan KG, O'Connor KM.* The effects of single-leg landing technique on ACL loading. *J Biomech* 2011; 44: 1845–1851
- 26 *Lovell R, Knapper B, Small K.* Physiological responses to SAFT90: a new soccer-specific match simulation. *Coach Sport Sci* 2008; 3: 46–76
- 27 *Lucci S, Cortes N, Van Lunen B, Ringleb S, Onate J.* Knee and hip sagittal and transverse plane changes after two fatigue protocols. *J Sci Med Sport* 2011; 14: 453–459
- 28 *Malfait B, Sankey S, Firhad Raja Azidin RM, Deschamps K, Vanrenterghem J, Robinson M a, Staes F, Verschueren S.* How reliable are lower-limb kinematics and kinetics during a drop vertical jump? *Med Sci Sports Exerc* 2014; 46: 678–685
- 29 *Markolf KL, Burchfield DM, Shapiro MM, Shepard MF, Finerman G a, Slauterbeck JL.* Combined knee loading states that generate high anterior cruciate ligament forces. *J Orthop Res* 1995; 13: 930–935
- 30 *Marshall PWM, Lovell R, Jeppesen GK, Andersen K, Siegler JC.* Hamstring Muscle Fatigue and Central Motor Output during a Simulated Soccer Match. *PLoS One* 2014; 9: e102753
- 31 *McLean SG, Fellin RE, Suedekum N, Calabrese G, Passerallo A, Joy S.* Impact of fatigue on gender-based high-risk landing strategies. *Med Sci Sports Exerc* 2007; 39: 502–514

- 32 *Mohr M, Krstrup P, Bangsbo J.* Fatigue in soccer : A brief review. *J Sports Sci* 2007; 23: 37–41
- 33 *Oberländer KD, Brüggemann G-P, Höher J, Karamanidis K.* Reduced knee joint moment in ACL deficient patients at a cost of dynamic stability during landing. *J Biomech* 2012; 45: 1387–1392
- 34 *Oh YK, Lipps DB, Ashton-Miller JA, Wojtys EM.* What strains the anterior cruciate ligament during a pivot landing? *Am J Sports Med* 2012; 40: 574–583
- 35 *Rahnama N, Reilly T, Lees A, Graham-Smith P.* Muscle fatigue induced by exercise simulating the work rate of competitive soccer. *J Sports Sci* 2003; 21: 933–942
- 36 *Raja Azidin RMF, Sankey S, Drust B, Robinson M a, Vanrenterghem J.* Effects of treadmill versus overground soccer match simulations on biomechanical markers of anterior cruciate ligament injury risk in side cutting. *J Sports Sci* 2015; 1–10
- 37 *Rampinini E, Bosio A, Ferraresi I, Petruolo A, Morelli A, Sassi A.* Match-related fatigue in soccer players. *Med Sci Sports Exerc* 2011; 43: 2161–2170
- 38 *Ruedl G, Webhofer M, Helle K, Strobl M, Schranz A, Fink C, Gatterer H, Burtscher M.* Leg dominance is a risk factor for noncontact anterior cruciate ligament injuries in female recreational skiers. *Am J Sports Med* 2012; 40: 1269–1273
- 39 *Samuelsson K, Desai N, McNair E, van Eck CF, Petzold M, Fu FH, Bhandari M, Karlsson J.* Level of evidence in anterior cruciate ligament reconstruction research: a systematic review. *Am J Sports Med* 2013; 41: 924–934
- 40 *Sanna G, O'Connor KM.* Fatigue-related changes in stance leg mechanics during sidestep cutting maneuvers. *Clin Biomech* 2008; 23: 946–954
- 41 *Shultz SJ, Schmitz RJ, Benjaminse A, Chaudhari AM, Collins M, Padua D a.* ACL Research Retreat VI: an update on ACL injury risk and prevention. *J Athl Train* 2012; 47: 591–603 Available from:
- 42 *Shultz SJ, Schmitz RJ, Cone JR, Henson R a., Montgomery MM, Pye ML, Tritsch AJ.* Changes in Fatigue, Multiplanar Knee Laxity, and Landing Biomechanics During Intermittent Exercise. *J Athl Train* 2015; 49: Epub ahead of print
- 43 *Small K, McNaughton L, Greig M, Lovell R.* The effects of multidirectional soccer-specific fatigue on markers of hamstring injury risk. *J Sci Med Sport* 2010; 13: 120–125
- 44 *Small K, McNaughton LR, Greig M, Lohkamp M, Lovell R.* Soccer fatigue, sprinting and hamstring injury risk. *Int J Sports Med* 2009; 30: 573–578
- 45 *Söderman K, Alfredson H, Pietilä T, Werner S.* Risk factors for leg injuries in female soccer players: a prospective investigation during one out-door season. *Knee Surg Sports Traumatol Arthrosc* 2001; 9: 313–321
- 46 *Tobin DP, Delahunt E.* The acute effect of a plyometric stimulus on jump performance in professional rugby players. *J Strength Cond Res* 2014; 28: 367–372

- 47 *Tsai L-C, Sigward SM, Pollard CD, Fletcher MJ, Powers CM.* Effects of fatigue and recovery on knee mechanics during side-step cutting. *Med Sci Sports Exerc* 2009; 41: 1952–1957
- 48 *Tschakert G, Kroepfl J, Hofmann P, Mueller A, Moser O, Groeschl W.* How to Regulate the Acute Physiological Response to “ Aerobic ” High-Intensity Interval Exercise. *J Sport Sci Med* 2015; 14: 29–36
- 49 *Vanrenterghem J, Gormley D, Robinson MA, Lees A.* Solutions for representing the whole-body centre of mass in side cutting manoeuvres based on data that is typically available for lower limb kinematics. *Gait Posture* 2010; 31: 517–521
- 50 *Vøllestad NK.* Measurement of human muscle fatigue. *J Neurosci Methods* 1997; 74: 219–227
- 51 *Wikstrom E a, Powers ME, Tillman MD.* Dynamic Stabilization Time After Isokinetic and Functional Fatigue. *J Athl Train* 2004; 39: 247–253
- 52 *Yeung SS, Suen AMY, Yeung EW.* A prospective cohort study of hamstring injuries in competitive sprinters: preseason muscle imbalance as a possible risk factor. *Br J Sports Med* 2009; 43: 589–594
- 53 *Yu B, Queen RM, Abbey AN, Liu Y, Moorman CT, Garrett WE.* Hamstring muscle kinematics and activation during overground sprinting. *J Biomech* 2008; 41: 3121–3126
- 54 *Zebis MK, Bencke J, Andersen LL, Alkjaer T, Suetta C, Mortensen P, Kjaer M, Aagaard P.* Acute fatigue impairs neuromuscular activity of anterior cruciate ligament-agonist muscles in female team handball players. *Scand J Med Sci Sports* 2011; 21: 833–840

## TABLES

**Table 1: Activity profile of SAFT<sup>5</sup> compared with the activity profile of 5 min of SAFT<sup>90</sup> with the order, speed and duration of each task represented.**

No	Activity SAFT <sup>5</sup>	Activity SAFT <sup>90</sup>	Speed (m/s)	Time (s)
0	10x Scissors			
1	Stand	Stand	0	4
2	Jog	Jog	2.86	10
3	CMJ (1x CMJ <sub>max</sub> + 9x 80% JumpHeight <sub>max</sub> )	Walk	1.39	17
4	Stride	Stride	4.17	7
5	Agility ladder drill	Walk	1.39	17
6	Jog	Jog	2.86	10
7	Sprint	Sprint	5.58	6
8	Stand	Stand	0	4
9	Jog	Jog	2.86	10
10	10x Scissors	Walk	1.39	17
11	Jog	Jog	2.86	10
12	CMJ (1x CMJ <sub>max</sub> + 9x 80% JumpHeight <sub>max</sub> )	Walk	1.39	17
13	Stride	Stride	4.17	7
14	Agility ladder drill	Walk	1.39	17
15	Stand	Stand	0	4
16	Jog	Jog	2.86	10
17	10x Scissors	Walk	1.39	17
18	Jog	Jog	2.86	10
19	Jog	Jog	2.86	10
20	Jog	Jog	2.86	10
21	CMJ (1x CMJ <sub>max</sub> + 9x 80% JumpHeight <sub>max</sub> )	Walk	1.39	17
22	Jog	Jog	2.86	10
23	Agility ladder drill	Walk	1.39	17
24	Stride	Stride	4.17	7
25	Stand	Stand	0	4
26	10x Scissors	Walk	1.39	17
27	Jog	Jog	2.86	10
28	Sprint	Walk	1.39	17



**Table 2: Timing and order of measurements (one maximum counter movement jump (CMJ), heart rate (HR), rate of perceived exertion (RPE), kinematics and kinetics of a single leg hop (SLH) and drop vertical jump (DVJ) of the non-dominant leg and maximum voluntary contractions of concentric and eccentric hamstring strength and concentric quadriceps (IKD)) during the 2 testing sessions.**

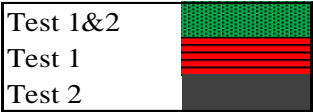
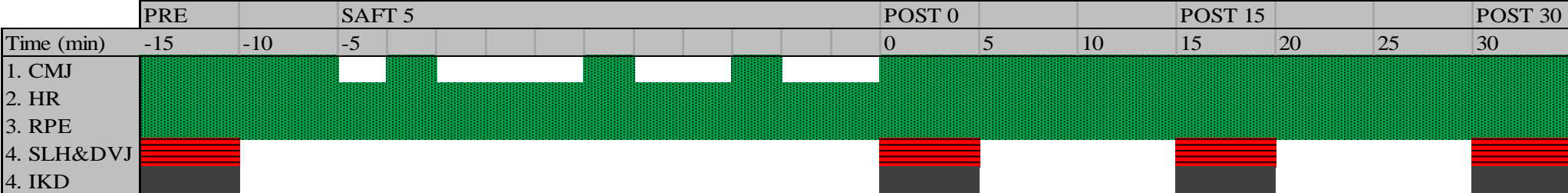

**Table 3: Mean  $\pm$  SD peak vertical ground reaction force (VGRF<sub>peak</sub>), knee joint rotations at initial contact (IC), and peak knee abduction moments during single-leg hop (SLH) and drop vertical jump (DVJ) prior to SAFT<sup>5</sup> (PRE), immediately after (POST0), after 15 min passive rest (POST15) and after 30 min passive rest (POST30).**

	SLH					DVJ				
	PRE	POST0	POST15	POST30	<i>F</i>	PRE	POST0	POST15	POST30	<i>F</i>
<b>GRF (N)</b>										
VGRF <sub>peak</sub>	1857 $\pm$ 325	1864 $\pm$ 375	<b>2099 <math>\pm</math> 363**</b>	<b>2027 <math>\pm</math> 395**</b>	$F_{2,18,30,51} = 10.26$ §	860 $\pm$ 246	898 $\pm$ 286	914 $\pm$ 257	930 $\pm$ 266	$F_{2,03,26,39} = 1.38$
<b>Knee Angle (°)</b>										
Flexion (-)	-13.7 $\pm$ 4.7	-11.5 $\pm$ 5.9	-11.3 $\pm$ 4.4	<b>-11.4 <math>\pm</math> 4.7*</b>	$F_{3,42} = 5.31$ §	-32.4 $\pm$ 8.6	-29.3 $\pm$ 8.7	-28.6 $\pm$ 8.2	-28.7 $\pm$ 10.2	$F_{2,14,29,89} = 2.44$
Internal rotation (+)	-0.5 $\pm$ 6.5	<b>3.6 <math>\pm</math> 7.7*</b>	<b>3.6 <math>\pm</math> 7.6*</b>	2.6 $\pm$ 8.0	$F_{1,89,26,49} = 8.68$ §	-2.6 $\pm$ 5.4	-0.8 $\pm$ 6.9	-1.6 $\pm$ 6.9	-1.1 $\pm$ 6.2	$F_{1,42,19,82} = 0.85$
<b>Knee Moment (Nm.kg<sup>-1</sup>)</b>										
Abduction (+)	0.30 $\pm$ 0.26	0.29 $\pm$ 0.25	0.36 $\pm$ 0.26	0.34 $\pm$ 0.26	$F_{1,77,24,80} = 2.19$	0.36 $\pm$ 0.14	0.44 $\pm$ 0.16	0.40 $\pm$ 0.15	0.39 $\pm$ 0.15	$F_{1,98,27,58} = 0.80$

*Note.* \* denotes statistically significant differences between marked POST-test and PRE ( $p < .05$ ). \*\* denotes statistically significant differences between marked POST-test and both PRE- and POST0. § denotes statistically significant main effect over time ( $p < .05$ ).

## FIGURES

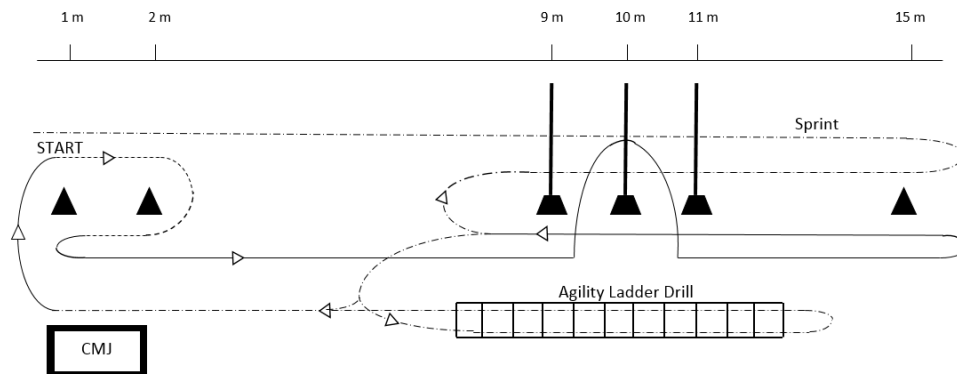

Figure 1: The SAFT<sup>5</sup> course. The participant received anticipatory instructions about the task and the speed for 5 min. The dotted line at the start of the course represents either upwards and backwards (“up jog”) or sideways running (“side”) around the second cone. The solid line represents forward running and sidestep cutting around the middle pole. The speed of the task was either “jog” or “stride”. Stride represented a speed between a jog and sprint. Once the participant arrived back at the first pole a second instruction was given. This instruction was either: (1) “sprint” or “jog”, which meant that the participant jogged or sprinted; (2) “agility ladder”, which meant that the participant performed the agility drill of running forwards with one foot per square and performing a final sprint once finished with the agility ladder drill; (3) “CMJ” or “Scissors” which meant that the participant performed 10 CMJ’s (1 maximum jump on a jump mat and 9 jumps at 80% of  $\text{JumpHeight}_{\text{max}}$ ) or 10 scissors at the black square that is represented on the figure.

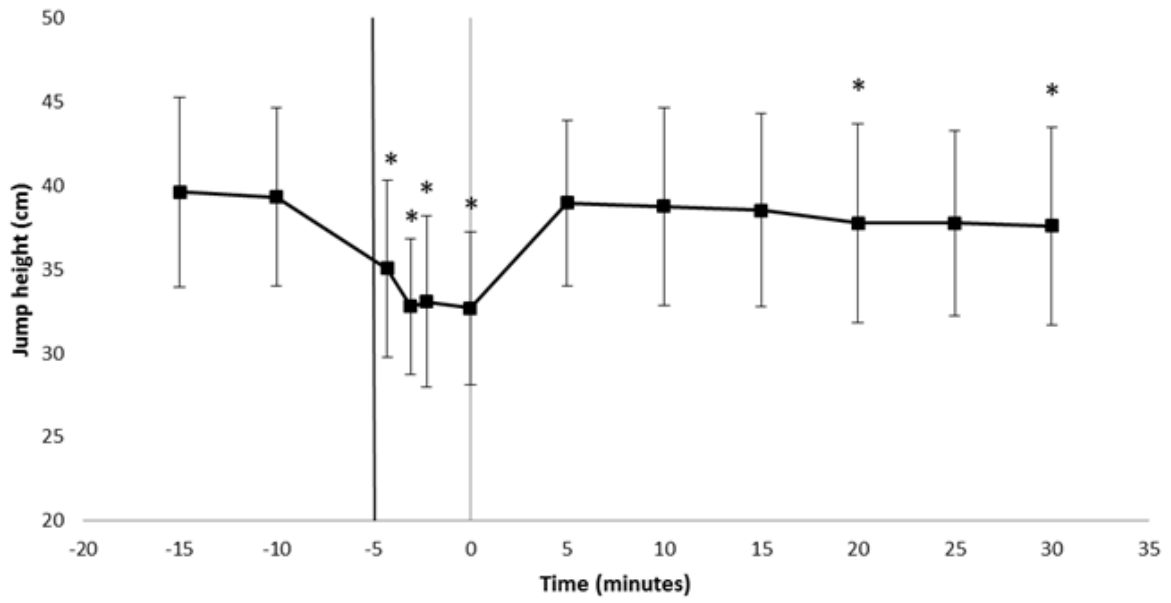

Figure 2: Maximum jump height pre (-15 min to -5 min), during (-5 min to 0 min) and post (0 min to 30 min) SAFT<sup>5</sup>. Vertical lines represent beginning (time -5) and end (time 0) of SAFT<sup>5</sup>. \*denotes statistical significant difference ( $p < 0.05$ ).

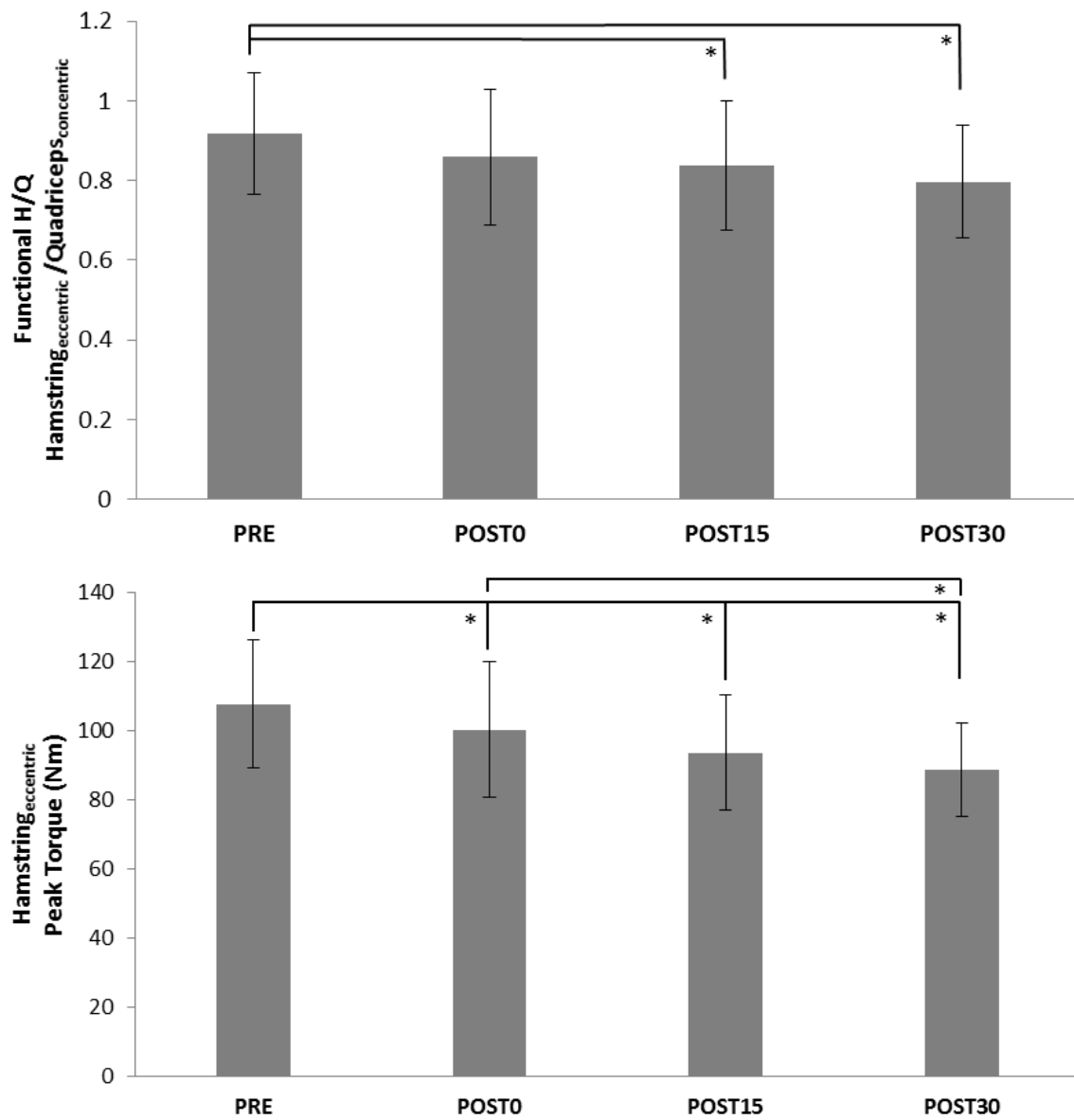
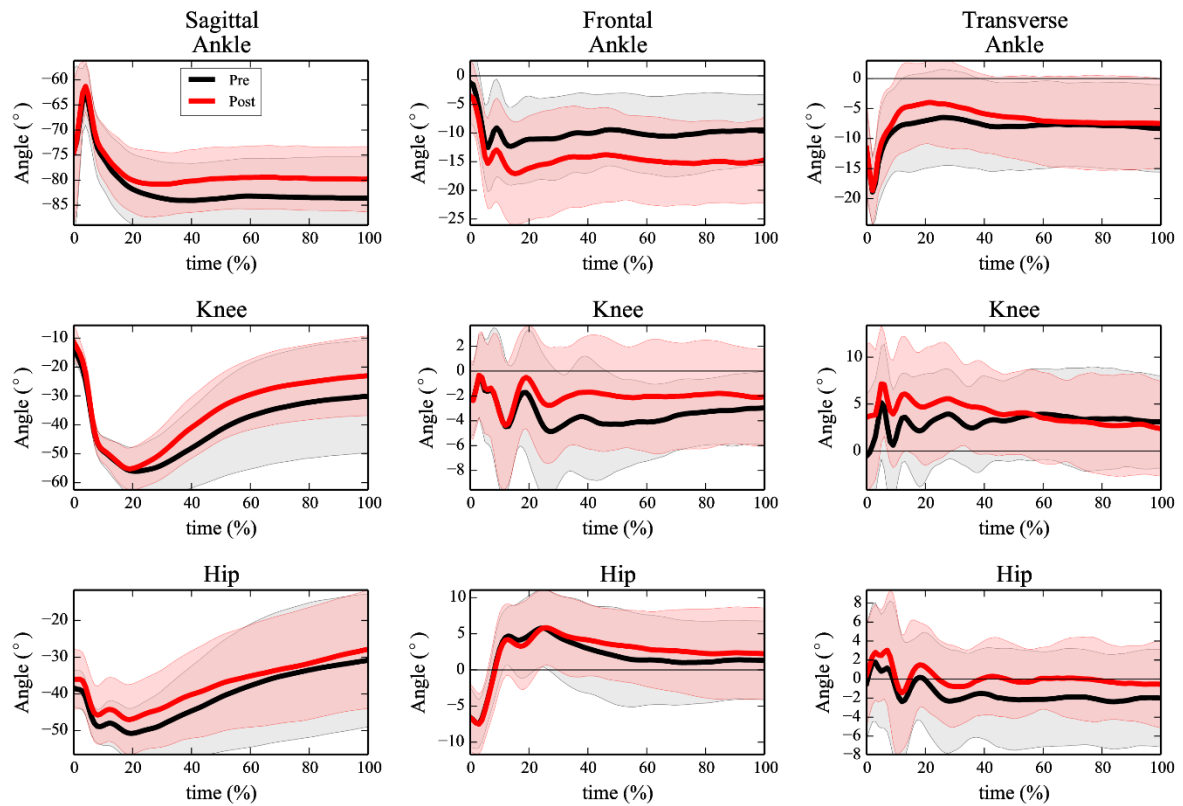
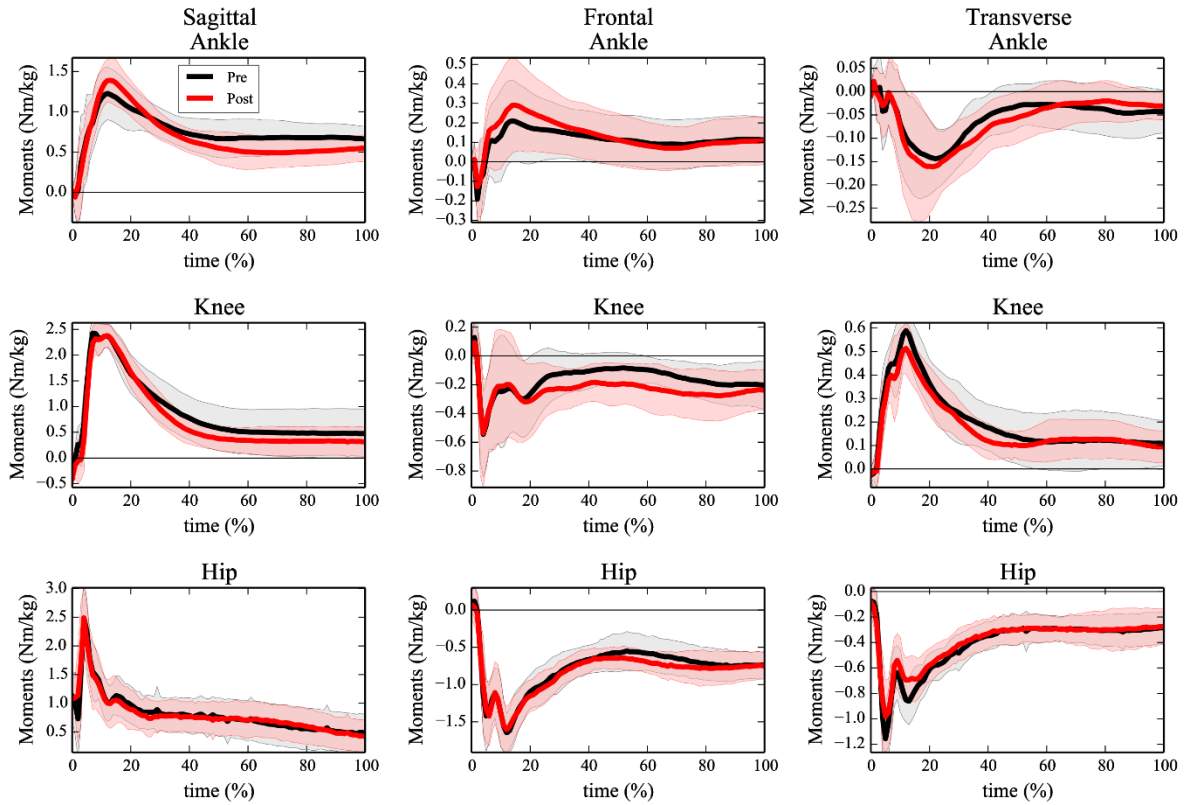

Figure 3: Functional HQ ratio ( $H_{eccentric}/Q_{concentric}$ ) and hamstring<sub>eccentric</sub> peak torque pre, during and post (0 min, 15 min and 30 min) SAFT5. \*denotes statistical significant difference ( $p < .05$ ).

## SUPPLEMENTARY DATA



Appendix 1: Ankle, knee and hip angles ( $^{\circ}$ ) (mean  $\pm$  SD) of sagittal, frontal and transversal plane during stance phase (initial contact + 1 s) of a single-leg hop pre and immediately post SAFT5. Black solid line represents PRE and red solid line represents POST.



Appendix 2: Ankle, knee and hip moments ( $\text{Nm}\cdot\text{kg}^{-1}$ ) (Mean  $\pm$  SD) of the sagittal, frontal and transversal plane during the stance phase (initial contact + 1 s) of a single-leg hop pre and immediately post SAFT<sup>5</sup>. Black solid line represents PRE and red solid line represents POST.