

**THE BIOARCHAEOLOGY OF KINSHIP:
PROPOSED REVISIONS TO ASSUMPTIONS GUIDING INTERPRETATION**

Bradley E. Ensor¹, Joel D. Irish², and William F. Keegan³

DO NOT CITE IN ANY CONTEXT WITHOUT AUTHORS' PERMISSION

¹Department of Sociology, Anthropology, and Criminology, Eastern Michigan University,
Ypsilanti, MI 48197, USA

² Research Centre in Evolutionary Anthropology and Paleoecology, Liverpool John Moores
University, Liverpool L3 3AF, UK

³ Florida Museum of Natural History, University of Florida, Gainesville, FL 32611, USA

Abstract

Bioarchaeology provides sophisticated techniques for estimating intra- and intercemetery biological relationships, i.e., biodistances, which can significantly expand anthropological research on kinship, explaining multiple dimensions of social life and identity in prehistory. However, some assumptions guiding the interpretation of results may need reconsideration. Although often assumed that descent groups should be homogeneous, social organizational and marriage practices actually produce heterogeneity within descent groups. Although interpretations on postmarital residence typically assume that spouses are buried together in the same cemetery, cross-cultural ethnographic patterns suggest that postmortem location does not universally follow residence. Nevertheless, cross-cultural data do indicate that postmortem location is generally predictable by type of descent group and whether membership with natal groups is maintained or transferred upon marriage. These issues are discussed, leading to alternative models on intra- and intercemetery biodistance expectations for matrilineal descent groups, for patrilineal descent groups with and without wives' membership transfers, and for a range of smaller groups under bilateral descent. The influence of common marriage alliance systems on intra- and intergroup phenotypic heterogeneity versus homogeneity are also described. The proposed biodistance expectations for interpreting different kinship and marriage strategies may better position bioarchaeologists to engage other subfields and make substantial contributions to kinship research.

Kinship persists as an essential anthropological subject. It has an inextricable relationship with sociopolitical organization, production and distribution, gender relations, spirituality, and identity. Kinship is therefore critical to understanding any past society and the changes impacting the social fabric of human lives from an anthropological perspective.

Although frequently portrayed as a disappearing cognitive or structural-functionalist subject in anthropology, kinship research actually became a critical component in research on political economy and gender relations since the 1970s (Peletz 1995). After a period of critique (e.g., Franklin and McKinnon 2001; Gillespie 2000a, 2000b; Kuper 1982), the subject remained important to political economic and gender theory, and postmodern perspectives on identity (e.g., Collier and Yanagisako 1987; Ellison 2009; Ensor 2011; Godelier 2011; Hutchinson 1996; McKnight 2004; Sahlins 2013). Using middle-range approaches, archaeological kinship analysis interprets postmarital residence and descent to address context-based social organizational strategies and the negotiation of gender relations and identities (Ensor 2013a, 2013b). Meanwhile, recent linguistic approaches to ethnographic kin term semantics attempt to “reconstruct” prehistoric kinship with interpretations guided by phylogenetic models and historical particularism (e.g., Jones and Milicik 2011; McConvell, Keen, and Hendery 2013).

Bioarchaeology has great potential to provide new interpretations on prehistoric kinship (see Stojanowski and Schillaci [2006] for a thorough review), and independently test ethnological, archaeological, and linguistic interpretations and theoretical models. However, only archaeology and bioarchaeology have access to data that date to the prehistoric periods in question. The development of kinship analysis in both subfields is therefore necessary for co-testing interpretations and contributing long-term perspectives. Within the current period of

anthropology, no subfield has maintained rigorous methodological development, analytical techniques, and attention to understanding its data to a higher degree than biological anthropology and, specifically, bioarchaeology. As such, the latter stands in an excellent position to contribute to, and potentially guide, broader kinship research across anthropology.

The subfield of bioarchaeology is methodologically rich in terms of using human skeletal remains to estimate biological relationships, or biodistances. Specifically, the latter can be obtained via a range of model-free and model-bound methods to characterize and compare phenotypic, i.e., metric and nonmetric (morphological), dental, cranial, and even post-cranial variables (e.g., Bedrick, Lapidus, and Powell 2000; Irish 2010; Konigsberg 1990, 2006; Relethford and Blangero 1990; Relethford and Lees 1982; Sjøvold 1977; Stojanowski and Schillaci 2006). However, some unacknowledged or unrecognized conceptual problems guiding estimates of biodistances may inhibit the potential for communicating across subfields. These problems include the persistence of a long discarded biological perspective; unreliable assumptions concerning kin group compositions, postmarital residence, and cemetery populations; and insufficient attention to marriage systems. In response, this essay provides revised interpretations for patterns in phenotype variation and biodistance resulting from different social organization and marriage strategies. Improvements in conceptualization of what patterns represent in terms of kinship would allow bioarchaeologists to better interpret phenotype distributions, and better engage in inter-subfield research on this topic. As a step toward this goal, perceived problems are discussed, points concerning kin group compositions and postmarital residence are clarified, revised models for interpreting phenotype data are presented, and the likely effects of marriage systems on gene flow are outlined. Before proceeding,

however, a common point of reference is useful. This focus here is on intra- and intercemetary biodistance analyses. These two categories are equivalent to the most specific of six geographic levels of analysis recognized by Scott and Turner (1997): individual, “family,” and local – which entails different settlements within regions; the other three broader levels, i.e., inter-regional, continental, and global, are little affected by variability in kinship patterns.

Assumptions Guiding Interpretation

Recurring problems in bioarchaeological kinship analyses involve neither the data nor the analytical techniques, but rather the conceptual frameworks for interpretation. An anthropologically-rejected understanding of kinship as biological relatedness persists to some degree in bioarchaeology. Traditional assumptions that descent groups are biologically homogeneous inaccurately portrays their social compositions. Models for interpreting postmarital residence mistakenly assume that spouses are universally buried together. Further, there appears to be a lack of sufficient attention to marriage systems that govern gene flow and phenotype distributions within and across kin groups. These problems suggest a need to revise biodistance expectations for interpreting kinship strategies.

Bioarchaeological approaches to kinship have a long, impressive history of attention to methodology and data for estimating biological relationships based on phenotypic, as well as genetic methods. Perhaps because of this focus, “kinship” largely became the subject of biological relatedness to identify loose concepts of “family” (e.g., Alt and Vach 1995, 1998; Alt et al. 1997). A biological perspective on kinship also occurs in other biologically-oriented fields and theoretical genres (e.g., evolutionary psychology, sociobiology, and genetics). However, this biological perspective on kinship was continuously critiqued in all anthropological theoretical

paradigms since the 1950s (e.g., Fortes 1959:149; Fox 1967; Gjessing 1956; Lévi-Strauss 1956; Sahlins 2013; Schneider 1984). For most anthropologists of the past half century, kin groups and marriage practices are viewed as socially constituted. Nevertheless, in a recent conference symposium with the contemporary goal to “move beyond the archaeological identification of biological kin to assessing social organization by exploring the interconnectivity of individual, kin-level, and population-level social identities” (Johnson and Paul 2014), six of 14 presentations still explicitly or implicitly emphasized kinship as the subject of biological relatedness (Ensor 2014). One social anthropologist recently noted in discussing another symposium that bioarchaeologists are too often non-reflexive, projecting Western notions of biological relatedness into their questions and analyses on what are actually nonbiologically-constituted social groups (Meyer 2014). There is also occasional confusion over terminology: e.g., use of “lineage” to denote biological descent, use of “affinity” as if kin groups were isolated from marriage and hence gene flow, and “family” as a universal construction (as above). These influences from biological perspectives suggest a lingering disconnect between bioarchaeological and anthropological perspectives.

Such inconsistencies with anthropological understandings can inhibit inter-subfield communication and lead to problematic assumptions guiding interpretations. For example, descent groups (i.e., members of lineages or clans) are frequently assumed to be biologically homogeneous (e.g., Howell and Kintigh 1996; Stojanowski and Scillaci 2006:53-64). In contrast, the social makeup of descent groups should prevent internal homogeneity. Figure 1 shows a hypothetical genealogy. The first point illustrated is that unilineal descent groups are not a collection of close biological relatives. The shaded matrilineally-related individuals comprising a

small matrilineage show small clusters of individuals with close biological relations; however, there are more distant biological relations among clusters. When those men and women are buried in the same matrilineage cemetery, phenotypes would exhibit intracemetery heterogeneity, especially considering gene flow through parents of other groups. If space provided a larger matrilineage or matriclan to illustrate, the figure would show even greater biological heterogeneity among members. The second point illustrated in the figure is that many close biological relatives do not share matrilineage membership and would therefore be buried in different descent group cemeteries. Thus, close biological relationships should be spread across descent group cemeteries & not concentrated within.

Although much attention has been paid to phenotypic traits and quantitative methods that lend themselves to kinship analysis (Konigsberg 1988; Schillaci and Stojanowski 2003; Tomczak and Powell 2003; Stojanowski and Schillaci 2006), less attention has been given to models for interpreting kinship behaviors & including assumptions about postmarital residence. For example, it is often assumed that spouses are buried together where they lived. Thus within cemeteries, greater variation in males than females is thought to indicate matrilocality/uxorilocality; greater variation in females than males suggests patrilocality/virilocality; and significant variation in both sexes indicates biolocality (e.g., Konigsberg 1988; Lane and Sublett 1972; Schillaci and Stojanowski 2003; Spence 1974; Tomczak and Powell 2003). Alternatively, through the same assumption, others suggest that postmarital residence may be detected by low inter-cemetery biodistances within one sex: matrilocality if males show less variation or patrilocality if females have less variation across groups' cemeteries (e.g., Aguiar and Neves 1991; Hubbe et al. 2009). The assumption that

spouses are buried together is certainly supported by many ethnographic examples. At the same time, however, ethnographic literature provides many examples of the deceased being returned to their own descent groups' cemeteries as a preference or rule (e.g., Keegan 2009). Thus, the linkage of burial location with postmarital residence is not universally supported. Nevertheless, this problem may be remedied by identifying the types of kinship strategies associated with spouse co-burial. If certain organizational strategies are predictably associated with spouse co-burial and others are not, then bioarchaeologists could expand their interpretations beyond postmarital residence.

To illustrate, the Electronic Human Relations Area Files were accessed to examine cross-cultural variation in postmortem location. A search by "All Cultures-and-Kin Groups & Kinship-and-Cemeter*" yielded 161 paragraphs in 115 documents for 68 cultures. Among them, ethnographic information on postmortem location practices of 28 cultures was obtained. The descriptions were examined for group membership, cemetery affiliation, postmortem location, and whether or not spouses transferred their membership upon marriage. As Table 1 illustrates, in all cultures of this sample having matrilineal descent groups, people were buried in their descent group cemeteries. Despite matrilocality, men were returned to their groups for burial and not interred in their wives' group cemeteries. In the cultures with patrilineal descent, women were also buried in their descent group cemetery. They were only buried in the same cemetery as their husbands if their membership was transferred to the husbands' groups upon marriage. Only in cultures with bilateral descent are spouses predictably buried together in the same cemetery. These data suggest that postmortem location is instead influenced by descent group membership or the use of bilateral descent.

A promising direction in bioarchaeology is the use of biocultural data to identify or test how cemeteries were socially constituted to ideologically reproduce identities and social relations (e.g., Bouwman 2014; Marshall 2014; Seidel and Nado 2014; Usher and Weets 2014; Zakrzewski 2014). This approach overcomes a potentially faulty assumption about what the cemetery units represent. However, this approach still needs improved models to make interpretations on specific kinship strategies B enabling conclusions on the negotiation of corporate organization, gender relationships, and identity construction.

Another objective of this article is to illustrate the importance of marriage systems on phenotype distributions within and across kin groups. Marriage prescriptions and proscriptions reproduce social organization. Unilineal descent groups must emphasize exogamy, despite most comembers' distant biological relatedness, to maintain their unilineal principles for membership and resource ownership in addition to creating necessary alliances with other groups (Fox 1967). Beyond exogamy, some marriage systems promote "inbreeding" of two groups that exclusively exchange spouses across generations. Others spread marital partners in unidirectional manners from one group to another resulting in gene flow among all groups. Others prevent individuals from marrying members of certain groups, despite the fact that most within those groups are not biologically related. Additional systems are individual- rather than group-based; they could promote potentially random marriage distributions, yet strategic preferences for alliances and resource security produce patterns. Whereas most children are conceived through marriages, thus inheriting alleles from spouses, marriage systems equally govern premarital behaviors toward courtship, and thus phenotypes of children born outside marriages. Essentially, marriage systems

govern gene flow, underscoring the fact that phenotypes and their distributions are *biocultural* phenomena structured by marriage systems as well as social organization.

Despite problems and omissions guiding interpretation, bioarchaeology has great potential to contribute to kinship research. Some reconceptualization and a fuller understanding of social organization and marriage, with which to adapt the existing methodological toolkits, should lead to more developed research. Thus, the goals here are to clarify and illuminate: 1) the social dimensions of different categories of corporate kin groups and marriage systems, 2) how these different strategies govern the distribution of biologically related individuals within and across groups, and most importantly 3) how those strategies variably structure postmortem location, so that bioarchaeologists may pair their biodistance results with more ethnographically-consistent models for interpretation.

Social Organization

This section summarizes major forms of kinship-based social organization, as a reminder or clarification of what is at stake when making interpretations, leading into the expectations for postmortem location and implications on intracemetery biodistance patterns. We intentionally avoid using terms such as “family” because it is too general and variably perceived to be analytically meaningful. We use “kin” or “relatives” only in a general sense, but always with specification to what kind of kin are referenced. A glossary at the end of the article provides a guide to terminology used herein, containing notes on distinctions and relations between the social and the biological (for a more comprehensive glossary, see Ensor 2013a). Emphasis is instead placed on the distinction between corporate and co-residing groups. Although mid-20th century kinship research emphasized numerous distinctions based on trivial classificatory

differences (e.g., lineages, sibs, clans, descent groups, etc.), simplification eventually emerged whereby "lineage" and "clan" now merely reference lower- and higher-order unilineal descent groups, no matter how these are used in a specific context (e.g., Fox 1967:50). Although most individuals within lineages and clans are not closely related biologically, the descent groups variably provide members with resources for making a living, mutual assistance, spiritual associations, and collective identities along with elder/leader authority over junior men and women for group success and perpetuation (Fox 1967; Keesing 1975; Scheffler 2001). Most biologically-related kindred relatives are unimportant in these regards, but may be used for secondary rights. In contrast, bilateral descent emphasizes *networks* of biological kindred and affinal relations, rather than exclusive corporate group strategies, for *negotiating* through more numerous relationships access to resources, mutual assistance, and identities. However, embedded within those networks, societies may emphasize any residential strategy from a wide range of alternatives.

Matrilineal *household groups* are small unilineal corporate groups that provide members with resources for making a living, mutual support, and collective identities (Ensor 2013a; Fox 1967; Keesing 1975). They consist of a set of adult siblings, their mothers and mothers' siblings, their matrilineal parallel cousins, and their children and female parallel cousins' children.

Matrilineages and/or matriclans are larger corporate descent groups with exclusive memberships along matrilineal principles entailing rights to resources, mutual support, and collective identities. More numerous, including more biologically distant, sets of matrilineal parallel cousins (emically referred to as sisters and brothers) make up these large corporate descent groups. Most of an individual's biologically-related kindred relatives are excluded from his or

her matrilineal descent groups. In some societies, subclan lineages provide resources and spirit associations whereas clans sponsor specific ceremonies for the rest of the society. However organized among descent groups, ceremonies require surplus production (for gifts and feasts) and inherited or achieved leadership roles. In societies with internal descent group ranking, leadership is passed to members of the descent group, not necessarily through primogeniture or to a specific gender, but through matrilineal descent (Keegan 2006). The matrilineages or matriclans must maintain exogamy to perpetuate this strategy for group membership. Descent group names enable individuals to immediately recognize how they can interact with others in terms of avoidance, joking, premarital sex, courtship, and marriage without needing to know everyone's genealogies.

Matrilocal residential groups reproduce the corporate household group through postmaritally mobile husbands, who remain members of their own household groups but labor for and contribute to the reproduction of their wives' household groups. Although situations in which men are frequently away from settlements have been argued to cause matrilocality (e.g., Ember and Ember 1971), the leading hypothesis is a need to localize women's engendered division of labor (Driver and Massey 1957; Fox 1967:77-85; Gough 1961:551-564; Korotayev 2003). When matrilineal descent groups have exclusive settlements within settlements, the local groups consist of the collection of matrilocal residential groups. Although present, men do not belong to the groups owning those locations, but rather to their own matrilineal descent group's estates at other settlements. If descent group membership is more important for resources, support, and identities, then the local group may comprise conjugal families residing in their own settlement (i.e., uxorilocality or avunculocality). These conjugal family residential groups should

not be confused with neolocality, which is not associated with unilineal descent. Interestingly, women in avunculocal societies never live with their matrilineal relatives; they grow up at their father's group location, postmaritally reside at their husband's group location, and are only with their matrilineal kin upon death (e.g., Keegan 2009).

Patrilineal household groups, centered around patrilineal parallel cousins, and much larger patrilineages and/or patrilans, entailing numerous and more biologically-distant sets of patrilineal parallel cousins, are also exclusive corporate descent groups providing members with resources, mutual support, spiritual associations, ceremonial roles, shared emically-intimate kin terms, and identities. The groups are reproduced through exogamy and patrilocal/virilocal. The leading hypothesis to explain patrilocal is a need to localize men's engendered division of labor and associated resources (Ember and Ember 1971; Fox 1967:77-85; Gough 1961:551-564). Virilocality, involving conjugal family residences at descent group locations, may be emphasized if membership and identity with the patrilineage/patrilan is more important than with household groups. Women remain members of their own group, where their loyalties, source of mutual support, and elders' control are focused despite being physically displaced. In many historic indigenous American cultures emphasizing patrilocal, women remained members of their own patrilineal groups. However, in other regions, and after European social engineering in the Americas, when patrilocal is combined with heightened gender inequality, married women's membership could be transferred to their husband's group. The patrilocally-displaced women not sharing natal group memberships thus came to be under the exclusive authority of the men in their husband's natal group.

With bilateral descent there are no descent groups. The largest corporate kin groups are at the scale of the household. Bilateral kindreds are not social groups, but rather individuals' networks of bilateral kin that cross-cut household-scale groups. This strategy provides flexibility for either spouse to identify "kin," access resources, and even re-negotiate membership in multiple households, which is why it is associated with resource uncertainty (e.g., Fox 1967:152-153; Gjessing 1975; Pasternak 1976). However, bilateral descent also creates divided loyalties and multiple sources of opportunities; exclusive descent groups do not (Fox 1967:152-153). Because there are none larger, some household groups may sponsor ceremonies or be a source for patron-client relations.

Under bilateral descent, household-scale groups could be corporate matrilineal household groups (reproduced with matrilocal residence), corporate patrilineal household groups (reproduced with patrilocal residence), or corporate bilocal residential-household groups. The latter, when combined with the flexibility of bilateral descent strategies, are described as "houses" by Lévi-Strauss (1982:163-187). With bilocality, and unlike matrilocality and patrilocality, membership to a corporate household group is entirely negotiated through bilateral relationships, using either spouse's kindred relatives. Thus, through multiple postmarital residence strategies, the household core group can include brothers, sisters, cousins (parallel and/or cross), and potentially people who are not biologically related to other members. At stake in the negotiations is each married couple's, and their children's, access to household resources with which to make a living. In this case, membership to the corporate group is through residence; the residential and household groups are the same (*residential-household group*). If internal ranking is present, any member could succeed, though there tends to be patrilineal bias

(e.g., Keesing 1975:93-94; Fox 1967). The leading hypotheses for bilocality involve small populations (Pasternak 1976:48), migration (Murdock 1949:204), resource shortages (Eggan 1966:58-64), and historic depopulation (Ember and Ember 1972).

Bilateral descent can also be associated with neolocality which, unlike uxoriolocality, avunculocality, or virilocality, occurs where conjugal families are unassociated with corporate kin groups of any kind or scale. The conjugal family is dependent on non-kin to make a living (e.g., through private property, wage labor, or serfdom). Kindred relatives are unimportant for making a living; therefore, extended households are not formed, but bilateral relatives of either spouse can be used to strategically develop networks of support and alliances, or even temporary work groups. Unlike household groups or residential-household groups, the neolocal conjugal family is not perpetuated across generations; it instead disintegrates when children establish new neolocal residences with their spouses (Fox 1967).

Corporate groups of different scales are thus created by manipulating gendered relationships. Each strategy provides access to resources, mutual assistance, spiritual associations, ceremonial organization, and identities. With unilineal descent, larger corporate descent groups are possible, i.e., lineages and clans. Important memberships are with the unilineal groups of origin or are transferred to those of husbands in some patrilineal strategies. With bilateral descent, corporate kin groups are restricted to the household scale, which can be associated with a variety of postmarital residence strategies. The focus now turns to the subject of group membership, postmortem location, and expected patterns for intracemetery biodistance for each of these strategies.

Postmortem Location and Intracemetery Biodistance

”Postmortem location” -- in which cemeteries and with whom people are interred – differs by kinship strategy. The major patterns are represented in Table 1. Expectations concerning biodistance are derived from these, considering group compositions. The modeled expectations assume multivariate analyses of morphological and/or metric cranial and/or dental traits. To simplify matters the expectations are for adults only; societies often vary in placement of children and, sometimes, subadult burials within kin group cemeteries – perhaps because they had not yet obtained the rights and duties recognized for full group membership (Carr 1995:184-185).

Cemeteries with definable boundaries at settlements indicate corporate groups. Saxe (1970) and Goldstein (1981) originally associated them with descent groups. However, Carr (1995:165) found that bounded cemeteries represent any form of corporate group including household-scale kin groups, descent groups, or even non-kin-based sodalities (Carr 1995:182). Large communal descent group cemeteries indicate that membership with larger groups were important for affiliation, access to resources, and identity. On the other hand, cemeteries only associated with individual households suggest that household group membership was more important. If both large communal descent group and household-oriented cemeteries are present at a settlement, then the importance of these scales of corporate affiliation may have been negotiated. In any of these scenarios, however, the entire unilineal descent group should have been the exogamous unit. With bilateral descent, there may also be large town cemeteries (sodality cemeteries) or only those for each household-scale group. Combinations of these strategies may imply identity negotiation.

The following models on expected intracemetery phenotypic variation are meant to be synchronic. However, kinship strategies to form corporate groups change over time as gendered relationships are manipulated to alter membership criteria (e.g., Ensor 2013a). A pattern in postmortem location for one phase may differ in other phases, even within the same cemeteries. Therefore, bioarchaeological kinship analysis needs to consider a given cemetery phase by phase; otherwise phenotype distributions from multiple strategies may be inadvertently pooled. In doing so, patterns would be obscured and the diachronic trends that lend themselves to testing many hypotheses on change would not be revealed.

As a reminder, large descent groups (lineages and clans) cannot be biologically homogeneous and postmarital residence does not predict postmortem location. We begin with large cemeteries for descent groups and for communities with bilateral descent that may also have communal cemeteries. Following these are the household-scale cemeteries with much smaller populations. The expected biodistance patterns are summarized in Table 2.

Matrilineal Descent Group Cemeteries

Among the 28 ethnographic cultures in Table 1, eight had exogamous matrilineal descent groups (matrilineages or matriclans). Seven of these had exclusive matrilineal descent group cemeteries. Among the Iroquois, Akan, Saramaka, Goajiro, Cibecue Western Apache, and Marshallese, the pattern was matrilineage or matriclan cemeteries for matrilineal members only. Men who lived matrilocally and/or women who lived avunculocally, were returned to their matrilineal descent groups' cemeteries upon death. Among the Tlingit, there were large multi-group cemeteries but each matrilineal descent group had its own location within them, and all individuals remained members of their matrilineal group despite matrilocality. The Ndyuka had

lineage-owned cemeteries and multi-lineage cemeteries. Among those with the latter, an exception to the general pattern, there was no separation of graves by lineage. Nevertheless, in each of these examples all members were returned to their matrilineal groups upon death for burial. Matrilineal postmortem location does not follow matrilineal postmarital residence.

As described and illustrated in Figure 1, few members of a matrilineage or larger matriclan share close biological relationships. Within a matrilineal descent group there should be multiple but biologically distant sets of biological siblings and their mothers. However, each set would be biologically distant from other sets within the matrilineal descent group; they cannot intermarry or produce offspring with one another due to descent group exogamy. Therefore, most individuals in a matrilineal cemetery should not be closely related biologically. Instead, there should be biodistance "clusters" representing numerous non-intermarrying mother-sibling groupings, though each should be distant from other intra-cemetery clusters. Figure 2-A illustrates a hypothetical multidimensional scaling (MDS) plot (e.g., see Kruskal and Wish 1978) for expected distances from a matrilineal descent group's cemetery. If the biodistance clusters are spatially clustered within the cemetery, greater significance to household group identity may be inferred. If not, then descent group identities can be interpreted as being more important.

The difference between these expectations for a matrilineal descent group cemetery and traditional assumptions have implications for intersubfield interpretation. For example, Schillaci and Stojanowski (2002, 2003) infer bilocality with a preference for patrilocality at Pueblo Bonito in Chaco Canyon based on intra- and intersex biodistances within two burial clusters, and when pooling the clusters. Close phenetic relationships between few males and females in one cluster was interpreted as group endogamy (Schillaci and Stojanowski 2003:10). This conclusion

involves two assumptions: 1) groups are biologically homogeneous and 2) spouses are buried together. Alternatively, in light of the above discussion, the same pattern may indicate that siblings of both sexes of a descent group were buried together. They also observed greater biodistance between sexes in the other burial cluster and, based on a sexes-pooled comparison from both clusters, greater phenotypic variation among females. Assuming spouse co-burial, this was interpreted as a preference for patrilocality. However, an MDS plot of inter-individual biodistances for both burial clusters (Stojanowski and Schillaci 2006, fig. 11) exhibits the clustering among few males and females, with intercluster differences, described here as what would be expected for *exogamous unilineal descent groups*. Given archaeological data that support matrilocality (Ensor 2013a:65; Peregrine 2001; Peregrine and Ember 2002), in addition to a community pattern conforming to settlements for exogamous unilineal descent groups (Ensor 2013a:141-160), these biodistance results would alternatively be interpreted here as evidence for an exogamous matrilineal descent group.

Patrilineal Descent Group Cemeteries

There may be two alternate expectations concerning patrilineal group cemeteries. First, the deceased are returned to their patrilineage's or patriclan's cemetery regardless of postmarital residence. Women who live patrilocally after marriage would be returned to their own patrilineal group. Second, women's membership is transferred to the descent group of their husbands upon marriage, and spouses are buried in the same cemetery. In either case, the patrilineage or larger patriclan cemeteries should exhibit internal biological heterogeneity, not homogeneity.

Of the 28 cultures in Table 1, 13 had patrilineal descent groups. All possessed exclusive cemeteries for exogamous descent groups or multiple group cemeteries with distinct descent

group areas. For six cultures, membership of women after marriage was unstated, including the: Mongo with exogamous phratry (related patriclans) cemeteries; Igbo with patrilineage compound cemeteries; Nenets, Nivkh, and Samoyed with exogamous patriclan cemeteries; and Aymara with town cemeteries divided by patrilineal moieties.

Tallensi women remained members of, and were buried in, their natal patriclan cemeteries. In these cases, because most members are not closely related biologically, the result should be heterogeneity: multiple clusters (each with biologically-close individuals) yet with significant inter-cluster distances. Additionally, no significant differences should exist between pooled subsamples of men and women. Figure 2-B illustrates a hypothetical MDS plot for expected biodistance patterns from a patrilineal descent group's cemetery without transfers of women's membership.

The problem with these expectations is that matrilineal and patrilineal descent group organization cannot be distinguished through phenotypic traits when spouses do not transfer their memberships (Figure 2-A and 2-B). Mitochondrial DNA, on the other hand, would be well suited for distinguishing the two. With matrilineal descent, all women and men should exhibit minimal mtDNA distance, despite variation expected in phenotypic traits. With patrilineal descent groups, women and men should exhibit marked mtDNA variation because mothers originate from multiple different patrilineal groups, and typically will have distant biological relationships (see discussion of Crow/Omaha marriage below).

Nevertheless, a potentially more common cross-cultural trend among societies with patrilineal descent is to transfer women's membership to the men's groups, which ultimately entails burial of postmaritally mobile wives in their husbands' patrilineage or patriclan

cemeteries. Among the 13 cultures (Table 1) with patrilineal descent groups, nearly half conformed to this second pattern: women transferred membership to their husbands' patrilineal groups and were buried in their husbands' patrilineage or patriclan cemetery. In this case, postmortem location matches postmarital residence. These cultures include the Shluh, Pashtun, Monguor, Serbs, Palestinians, and Korean rural lineages. Regarding variation in using patrilineage village cemeteries among the Pashtun, Barth (1965:39) states "when she dies a wife is usually buried in the section of the village cemetery used by her husband's patriline; but usage in this respect varies in different localities. The return of the woman's body to her natal village is a recognized gesture of deference towards affines and matrilineal relations." Variation may also occur with the timing of membership transferral. Among Serbs having clan or village cemeteries with separate clan spaces, Filipovic (1982:49) states that "a woman becomes a part of her husband's rod only when she bears him a child. In...Sumadija, for example, if a young woman dies before she has borne children she is not buried in the graveyard of her husband's clan but in that of her parents."

When women's memberships are transferred to their husbands' groups, the same phenotypic clusters of few biologically close members, with intercluster differences, should occur, though only among men. Adult females from multiple other descent groups should be even more heterogenous relative to males. And for the same reason, pooled adult females should exhibit significant differences from pooled adult males. Figure 2-C is an MDS plot that would be expected for a patrilineal descent group's cemetery *with* transfers of women's membership. Interpreting the transfer of women's membership also extends to an interpretation of significant gender inequality.

The expected biodistance clusters (of males and females, without women's membership transfers, or among males only, with women's membership transfers) may or may not conform to spatial clustering. If they do, it may illustrate that household group identity was emphasized alongside lineage or clan identity. If not, then identity with the higher-order lineage or clan can be interpreted as being more important than household group identity.

Bilateral Descent and Large Cemeteries

With bilateral descent, and the lack of corporate descent groups above the household scale, residence determines postmortem location. For aggregated settlements considered now, non-kin-based sodalities may be the basis for larger corporate social functions and cemetery organization (e.g., town cemeteries), which again are determined by where one resides. Married men and women are expected to be buried in the same cemetery, and possibly in close spatial proximity. Residential influence on postmortem location is illustrated in the seven cultures with bilateral descent (Table 1).

Representing bilocality, the Lozi had cemeteries for multiple dispersed residential-household groups in which spouses were buried together. This is similar to a town cemetery but without aggregated settlement. Keeping in mind that in cultures where bilateral descent is combined with bilocality, some married men and women remain in their natal residences while others do not. Non-biologically related spouses can also be members, and more distant biological cousins may also negotiate their way into residential groups using bilateral kindred relations. Both within and among residential-household groups that share a cemetery, like among the Lozi, clusters of few close biological relations and a continuum of among-cluster distances should result. Men should exhibit a continuum of biodistance variation, as should women, but pooled

adult males and females should not differ significantly (Figure 2-D). Because bilocality and bilateral descent tend to have patrilocal biases (e.g., Keesing 1975:93-94; Fox 1967), there may be slightly greater similarities among men than women.

Even with unilocality, residence determines postmortem location under bilateral descent. Nine cultures in Table 1 practiced matrilocality. Among these, only the bilateral Cuna buried married men with their wives. This example again illustrates how residence determines postmortem location under bilateral descent. When bilateral descent is combined with matrilocality, men from multiple different groups will be buried in the same cemeteries as their wives. In this case, clusters of close biological distances should be among few women only, because their brothers are buried in their wives' cemeteries. Males, the recruited husbands, because they originate from different groups, should display marked variation, and if pooled should be significantly different from females (Figure 2-E).

Among the patrilocal Bella Coola, Tongan commoners of Pangai, and Tzeltal Maya experiencing a shift from patrilineage organization to bilateral descent, married men and women along with deceased unmarried children, were buried together in village cemeteries and patrilocal residence determined postmortem location. With practices like that, intracemetery biodistance analyses should have results opposite to those for matrilocality under bilateral descent: clusters should be among few close biologically-related men only (because their sisters would be buried in their husbands' cemeteries). Because wives originate from multiple other groups, they should be heterogeneous and, when pooling by sex, significantly different from males (Figure 2-F).

Neolocality, which is always associated with bilateral descent, also governs postmortem placement. Among the Highland Scots, neolocal conjugal families had plots in village cemeteries. However, neolocal conjugal families among the Greek refugee community used town cemeteries without conjugal family plots. In the case of village cemeteries, biodistance clusters of few individuals should occur, yet with the same continuum expected for bilocality. For larger cemeteries serving urban populations, there should be great distances among the numerous, non-biologically related small clusters. These results may or may not conform to spatial clusters in burials.

Small Household-Scale Cemeteries

In many cultures, cemeteries were established for household-scale groups. In these cases, each household, consisting of the physical dwellings, support structures, and communal spaces were also associated with a small cemetery. This may occur with widely dispersed farmsteads or even in villages lacking communal cemeteries. Such cemeteries signify that whether larger corporate groups exist or not, the household-scale groups were more important for identity. Household-scale cemeteries may even accompany larger communal cemeteries for corporate descent groups, indicating negotiation of the importance of identities between household groups and their larger descent groups. Household-scale cemeteries require some modifications to the expectations described above, because – unlike lineage- or clan-scale cemeteries - they are small and include only people having close biological relationships: i.e. only members of an extended family.

Cemeteries for matrilineal household groups within matrilineages or matriclans should include siblings of both sexes, their mothers and her siblings of both sexes, and matrilineal

parallel cousins of both sexes. More distant descent group members would be buried in their matrilineal household group cemeteries. The results of a multivariate biodistance analysis should demonstrate low variation among all individuals with no significant differences between pooled male and female subsamples. In other words, unlike matrilineage- and matriclan-scale cemeteries, intracemetery homogeneity among members should be expected in matrilineal household-scale cemeteries.

Cemeteries for patrilineal household groups within patrilineages or patrilans, *without* the transferring of married women's membership, would be comprised of patrilineally-related siblings of both sexes, fathers and their siblings of both sexes, and patrilineal parallel cousins of both sexes. Excluded would be more biologically-distant members of the same patrilineal descent group if each patrilineal household group has its own small cemetery. An intracemetery multivariate biodistance analysis should result in low variation among all individuals, and without significant differences between pooled males and females: the same results for matrilineal household group cemeteries within matrilineal descent groups.

A different expectation is made if wives' membership *is* transferred to their husbands' groups. All patrilineally-related men of the group would still be interred together: male siblings, their fathers and fathers' brothers, and patrilineal parallel male cousins. Excluded would be married sisters, patrilineal parallel female cousins, and patrilineal aunts (fathers' sisters). Replacing these women would be the wives who originated from other patrilineal groups. The household-scale cemetery population should exhibit low distances among all males, significant differences between pooled males and females, and greater heterogeneity among females.

Cemetery populations for individual bilocal residential-household groups under bilateral descent could include *some* siblings of *either* sex, mothers *and* fathers (and *some* of their siblings of *either* sex), *some* patrilineal and/or matrilineal parallel and/or cross cousins of *either* sex, and *some* non-biologically related wives and/or husbands. Despite the wide variation in potential bilocal residential-household group compositions, the expected pattern is simple. Most males and females should exhibit low biodistances. However, *some* males and *some* females should exhibit greater distances and greater heterogeneity.

Cemetery populations for matrilineal residential groups under bilateral descent would include the matrilineally-related females (sisters, their mothers and their sisters, and matrilineal parallel female cousins), all with close biological affinities. However, because postmortem location conforms with residential group membership under bilateral descent, the cemetery should also contain non-biologically related males (husbands from other groups) who should exhibit greater distances from the females, when both are pooled, and exhibit greater heterogeneity.

Cemeteries for patrilineal residential groups under bilateral descent should include males with close biological affinities (brothers, their fathers and their brothers, and patrilineal parallel male cousins). Surrounding this core, outliers would include in-marrying females who originate from different multiple groups; they would exhibit notable heterogeneity and significant differences relative to the males.

As demonstrated, modeling of biodistance within cemeteries is far more complicated than previously assumed. Nevertheless, distinctive models for intracemetery biodistance can be produced for different kinship strategies when considering associated patterns in postmortem

location and group compositions. These considerations allow more precise and better informed interpretations on social organizations and their significance to gender dynamics and identities. However, the models in this section do not consider the effects of marriage. Phenotypes themselves are the products of marriages and inheritance; they are a *biocultural* phenomenon. To understand phenotype frequency distributions within and across groups, and hence within and across cemeteries and settlements, marriage systems must be considered.

Marriage Systems: Gene Flow and Phenotype Distributions

Marriage rules prohibit random mating, and thus channel patterns in gene flow among corporate groups. Because marriage systems govern the distribution of alleles, they are cultural practices guiding the creation of phenotypes and their frequencies within and among populations. Within populations, marriage systems may prevent the exchange of alleles among some groups while encouraging their distribution among others. Certain marriage systems create biological linkages among only few members of corporate kin groups in a way that prevents other biological relationships within and across groups from developing. The three major categories of marriage systems introduced by Lévi-Strauss (1965, 1969) are elementary alliances, complex alliances, and Crow/Omaha alliances. The purpose of any marital system is to socially reproduce the given social organization while ensuring marriages for the perpetuation of the groups through reciprocal or competitive “exchanges.” However, each system directs gene flow among groups in different ways.

All unilineal groups must maintain preferences, if not *de jure* rules, for exogamy. Given exogamy, there should be little gene flow among members of matrilineal or patrilineal household groups, lineages, or clans. The exogamy associated with these forms of social organization

compel gene flow with other groups. Two marriage systems are associated with unilineal descent groups: elementary (with two major forms) and Crow/Omaha.

With elementary alliances, each unilineal descent group has a specific marriage pool B another unilineal descent group with which it “exchanges” sons if matrilineal, or daughters if patrilineal. In restricted elementary systems only two groups intermarry; groups A and B always “exchange” members, creating reciprocal alliances between groups. The reciprocal alliances enable access to resources among the two groups’ members and provide a source of social security (e.g., Fox 1967; Lévi-Strauss 1969). Likewise, groups C and D always intermarry to form reciprocal alliances. In this case, all members of descent groups A and B should exhibit close biological relatedness among both males and females, all members of descent groups C and D should exhibit close biological relatedness among both males and females, but the pooled males and females of the A-B groups should exhibit greater biodistance from the pooled C-D groups. A more broadly scaled analysis should result in pairs of phenotypically-close descent group cemeteries, with significant differences among the multiple pairs.

In generalized elementary systems, and assuming four descent groups for this example, Group A only “gives” spouses to Group B, which only “gives” spouses to Group C, which only “gives” spouses to Group D, which only “gives” spouses to Group A (Fox 1967; Lévi-Strauss 1969). The exchanges are another form of reciprocity, but link many more groups throughout the society. Gene flow is therefore circular: from A to B, B to C, C to D, and D to A. From the time this system of reciprocal alliances is adopted it should take several generations for gene flow to lower the intergroup genetic distances, creating homogeneity both within and among the descent

group members. On a broader scale, all cemetery populations (males and females) should exhibit greater homogeneity over time.

There are no descent group-oriented rules in Complex marital alliances. This system is associated with bilateral descent, which lacks descent groups. Marriage rules are individual-based taboos on marrying close consanguineal bilateral relatives. The taboos may only pertain to biological parents and siblings, or may be extended to cousins. There are no prescribed marriage pools; each household must compete to attract marital alliances for members to ensure perpetuation of the corporate group (Fox 1967; Lévi-Strauss 1969). The result is a network of maritally-based social alliances cross-cutting household groups within and among settlements. If bilocal, and lacking a prohibition against cousin marriage, then members of the same natal residential-household group could potentially intermarry to retain inheritance rights among group members. For this reason, gene flow will occur among some members within household groups but not among all. Biodistance clustering should therefore involve individuals across multiple household cemeteries within and across settlements. Unilineal household groups' exogamous preferences may be added, resulting in the expectations for matrilineal or patrilineal household groups under bilateral descent. If there is a preference for village endogamy, usually to keep access to resources among groups within the settlement, then biodistance clustering within and among a settlement's cemetery populations can be expected, though there should be greater differences between settlement populations. If there is a preference for village exogamy, usually to establish alliances with other settlements as a form of social security, then biodistance clustering across settlements can be expected.

Crow/Omaha marital alliances have characteristics of both elementary and complex marriage systems (Fox 1967). In addition to descent group-based rules, there are also individual-focused rules. Marriages are among members of different exogamous clans (or lineages in the absence of clans). The matrilineal version is the Crow system. In addition to matriclan exogamy (despite distant biological relations among most clanmates), each individual is also prohibited from marrying any member of their father's matriclan (despite most of them having distant biological relationships to the father) (Fox 1967; Lévi-Strauss 1965). An additional prohibition may be extended to all members of mother's father's matriclan (despite most in that clan having distant biological relationships to the mother's father). In the patrilineal Omaha version, the rules include patriclan exogamy and a prohibition against marrying members of mother's patriclan, sometimes extended to father's mother's patriclan (even though most members of these clans have distant biological relationships) (Fox 1967; Lévi-Strauss 1965). Empirical data on marriages indicate that the Omaha proper greatly adhered to these prohibitions in the nineteenth century (Ensor 2003). Crow/Omaha prohibitions are a social strategy to more evenly distribute marriage alliances (and, by consequence, gene flow) among more numerous clans.

Taking a closer look at the Crow/Omaha systems, different siblingships within a clan receive alleles and spread them among different sets of clans. In the Crow system, a set of siblings receives alleles from few members of their own clan (through their mother, and her mother), from their father's clan (through their father and his mother), and from their mother's father's clan (through their mother's father and his mother). The same siblings may find spouses in any one of the additional clans that are not prohibited. Brothers will pass alleles to their children belonging to, and eventually buried with, other clans. Interclan biodistance clustering is

created in this way. However, different siblingships within a given clan have different fathers' clans and different mothers' fathers' clans, which means that each clan as a whole has biological connections with all others: indicated by both intra- and interclan biodistance clustering.

Table 3 illustrates how this clustering occurs in a hypothetical society comprised of six exogamous matriclans. Clan A has five sets of siblings, each with fathers and mother's fathers belonging to different clans. For sibling set 1 of Clan A, their father belongs to Clan D and their mother's father belongs to Clan F. Children of the women of sibling set 1 will obtain alleles from their mothers in Clan A, which is also their clan, and will obtain alleles from their mothers' husbands who must come from Clan B, C, or E. The men of sibling set 1 will pass alleles to their children who belong to their wife's clans (either B, C, or E) and those children will also receive alleles from their mother in their own clan. However, other sibling sets in Clan A have received alleles from members of different clans because they have different fathers and mothers' fathers. Thus they have different permitted clans to which they may pass alleles through the men. This arrangement is yet another way to explain how the Crow marriage system perpetuates intraclan heterogeneity and biodistance clustering among members of different clans.

An example of how these expectations are matched in a bioarchaeological study of a prehistoric society can be illustrated with Howell's and Kintigh's (1996) biodistance results from multiple cemeteries at the ancestral Zuni settlement of Hawikku. From their maps and descriptions, the pueblo consisted of five large room blocks and 10 cemeteries with a total 873 identified burials. To test whether or not the cemeteries were for lineages or clans, they conducted a multivariate cluster analysis on 54 individuals having sufficient numbers of traits recorded from seven cemeteries. Six trait "clusters," labeled A through F were identified. Some

cemeteries were dominated by one trait cluster, suggesting close biological relatedness; there were also several instances of individuals interred near one another who shared the same trait clusters, suggesting “family” locations within cemeteries. Although demonstrating that these results were nonrandom, *each trait cluster was found in multiple cemeteries*. To illustrate, trait cluster A was shared by four individuals in Cemetery 1, five in Cemetery 3, and seven in Cemetery 9. Because they assumed each descent group should be relatively homogeneous, these results contradicted their expectations for descent group cemeteries, leading them to consider disruptive factors (spouses buried together, adoption of nonbiological kin, breaking prescriptions on burial locations, merging of different kin groups’ cemetery spaces over time, and fissioning). However, their results are those that would be expected based on the assumptions herein for multiple exogamous descent groups engaged in a Crow/Omaha marriage system.

Hawikku was a large settlement that apparently had intermarrying exogamous descent groups. However, it may be more common cross-culturally, or for certain periods without such aggregation, for descent groups to have individual settlements distributed across the landscape. A broad perspective is therefore required to identify marriage systems. Data from one cemetery population, or comparisons of two or few cemeteries within a single settlement, cannot adequately reflect the expected phenotype distributions created by marriage systems. If bioarchaeologists are restricted to one site for analysis, when socially-constructed kinship relations and marriage transcend settlements, the result is partial glimpses of a larger system of relationships.

Although not the cemetery-by-cemetery analyses within and across sites at a regional scale we are calling for, one example of a regional perspective that does consider marriage

practices is by Stefan (1999); he looked at craniometric data from different tribal regions across Rapa Nui. Given homogeneity across tribal populations, lineage exogamy within and across tribes (for commoners) was interpreted. However, when considering the lack of significant differences between sexes, Stefan assumes that spouses were buried together leading to the interpretation of notable levels of lineage endogamy. If endogamous, then lineage organization would break down. As an alternative, we suggest that the internal homogeneity across areas was due to Crow-Omaha-like lineage prohibitions compelling each to form marital alliances among numerous lineages; further, the homogeneity among sexes within tribal areas likely had more to do with centuries of exogamous gene flow and the return of individuals to their natal locations for burial rather than lineage endogamy.

Some caution is necessary when interpreting changing phenotype frequencies and distributions. Like intracemetery biodistance research, marriage systems should also be examined chronologically on a phase-by-phase basis to avoid the compiling of phenotype distributions caused by changing marriage practices. Moreover, a change in marriage systems should lead to changes in phenotype distributions, which may in turn be confused for population migrations or replacements interpreted through culture historical perspectives; the latter may serve to inflame controversies over dominant ethnic groups' versus indigenous populations' claims on ancestral lands and territories. It is therefore important to acknowledge that changing marriage systems influence population phenotype frequencies and distributions, which can also open doors to new research on old interpretations.

This section provides only a brief sketch of marital systems. Nevertheless, the overview of these major categories should be sufficient to illustrate their role in regulating gene flow and

phenotype distributions within and among kin groups. Their study seems a necessary but largely unexplored area in bioarchaeological research on kinship but could aid in the interpretation and understanding of prehistoric kinship while expanding the scope of research.

Prospects

The ethnologically-derived models of kinship behavior and social organization described here have far more complex implications on phenotype distributions than commonly assumed in previous bioarchaeological literature. The major takeaway points are that kinship is not the subject of biological relatedness, postmortem location does not always correspond to postmarital residence and is instead governed by group membership, descent groups are not homogeneous, and marriage systems are essential for understanding phenotype distributions. Alternative biodistance models were introduced to better distinguish different unilineal descent groups, bilateral descent, and the effects of marriage systems. A more sophisticated bioarchaeology of kinship is within reach to apply the advanced model-free and model-bound quantitative methods already in use. Once interpretive models are reconceptualized, bioarchaeologists will be in a stronger position to communicate more effectively across subfields engaged in kinship analyses, and test other subfields' interpretations and generalizing hypotheses on kinship. Moreover, bioarchaeologists alone are forced to examine the *interface* between biological data and socially-constructed kin groups – a relationship that ethnologists, archaeologists, and linguists can conveniently avoid. As this essay emphasizes, different kinship and marriage strategies result in variable biological interconnectedness within and across social groups. As such, bioarchaeology should be central to discussions on the culturally-constructed relationships between kinship strategies and biology.

By interpreting the ways that past humans manipulated social relationships to form groups, how genders were influenced by those strategies, and how identities were negotiated, bioarchaeology has a large contributive role to play in anthropology. The challenges are many, when considering the complex implications on phenotype distributions described here. Nevertheless, it is most likely that the subfield's methodological and statistical expertise can be applied to address kinship in a more sophisticated manner, creating opportunities for contributions to broader anthropological understandings of variable and changing human social life.

Acknowledgements

The authors thank the anonymous reviewers for helpful comments and hope our resulting revisions better relate the kinship concepts herein to the targeted audience of bioarchaeologists. Special thanks goes to Christiane Cunnar and Lisa Klopfer, who facilitated access to the eHRAF. The article also benefitted from the current perspectives presented in the “Bioarchaeological Approaches to Kinship: Bridging Biology, Social Relatedness, and Theory” symposium at the 79th Annual Meeting of the Society for American Archaeology, for which thanks go to the organizers (Kent Johnson and Kathleen Paul) and all the participants.

Glossary

Affine: A relative through marriage.

Avunculocality: A postmarital residence practice whereby a married couple resides with the *matrilineal descent group* of the husband's matrilineal uncle.

Bilateral descent: Descent reckoning placing emphasis on mother's and father's sides, including all those descended from mother's mother and father (and their siblings), and all those descended from father's mother and father (and their siblings). The basis for individual *kindreds*. Bilateral descent crosses kin groups, thus dividing individuals' loyalties while at the same time providing negotiable opportunities for support. The major form of marriage in Western cultures that ideologically emphasize individuals and biological relatedness but which does not conform with the social and biological makeup of unilineal descent groups (*lineages* or *clans*).

Bilocality: A postmarital residence practice whereby each married couple negotiates whether to reside at the wife's or the husband's natal residence, or potentially another residence via *bilateral descent*.

Bilocal residential-household group: An extended residential group – usually a corporate property-owning group - formed through the *bilocality* of its members. Unlike corporate groups in matrilineal and patrilineal societies, the residential group and the corporate group are the same.

Clan: Not a biological collection of *kin*. A large exogamous unilineal descent group (with potentially hundreds or even thousands of members) whereby members trace descent with one another matrilineally (a matriclan) or patrilineally (a patriclan) back to known or

mythical founding ancestors, thus excluding most of each individual member's biological *kindred* relatives. Societies differ in corporate clan functions: in some they collectively own property, in most they sponsor ceremonies, in all they provide a large group for mutual support from, and obligations to, members (regardless of biological distance) that may not extend to biologically close members of other clans. Clans commonly comprise multiple sub-clan *lineages*.

Complex Marriage: An individual-based marriage system (as opposed to a group-based marriage system) with one rule prohibiting marriages among biologically “close *kin*” (variably defined by cultures) associated with *bilateral descent*, thus spreading marriages – and biological relations of children – across groups potentially randomly or, depending on customary preferences, within or across settlements, classes, ethnicities, or levels of educational attainment. The major form of marriage in Western cultures that ideologically emphasize individuals and biological relatedness.

Conjugal family: At a minimum, a mother and her child(ren) but usually including two or more parents and child(ren). Preferred over “nuclear family” to avoid the false Western connotation of a universal biological “building block” of kinship.

Crow Marriage: A matrilineal descent group-based marriage system whereby individuals and their siblings are prohibited from marrying anyone in their own exogamous matriclan (even though most members are biologically distant), their father's matriclan (even though most members are biologically distant to father), and in some societies their mother's father's matriclan (even though most members are biologically distant to mother's father). Marriage with members of other clans are permissible (regardless of

biological distance to their members). The proscriptions disperse marriages – and gene flow – across numerous clans, inhibiting intense gene flow between two or few clans. In the absence of clans, the same rules may apply to exogamous matrilineages.

Elementary Marriage: A descent group-based marriage system (for matrilineal or patrilineal descent groups) whereby individuals must marry someone in another prescribed descent group. In the restricted form, two groups “exchange” people in marriage (e.g. $A \leftrightarrow B$, $C \leftrightarrow D$) resulting in close biological relatedness between the pair of “exchanging” groups but with no gene flow to additional groups. In the generalized form, a group always “gives” spouses to a specified second group, but always “receives” spouses from another specified group (e.g., $A \rightarrow B \rightarrow C \rightarrow D \rightarrow A$), resulting in gene flow across all groups.

Exogamy: A rule or preference for marriage outside one’s social group (however defined). The opposite is endogamy (rule or preference for marriage within one’s social group). In the case of unilineal descent groups, the groups must be exogamous to maintain the principle of unilineal descent group membership. In the case of bilateral descent and complex marriage, exogamy or endogamy may be preferences.

Family: A vague, non-specific term with numerous variable meanings within and across cultures and social sciences. Sometimes but not necessarily conceptualized as socially-based, biologically-based, group-based, and/or network-based.

Household group: A corporate property-owning extended family with exclusive membership, herein emphasizing those based on unilineal descent. Not to be confused with a *residential group*.

Kin: a non-specific, generalized, and variably meaning reference to social and/or biological relations.

Kin Group: a non-specific, generalized, and variably meaning reference to social groups (having an identifiable membership) organized through any of the numerous possible principles.

Kindred: Not a group, but rather, a specific reference to an individual's bilateral and consanguineal (biologically-related) network of *kin*. In some societies, affines may be customarily included. With the exception of siblings, different individuals have different kindreds, regardless of whether they belong to the same social groups or not. In societies emphasizing bilateral descent, kindred relations may be used to form temporary work groups. Recognized kindreds are as large as they are useful; in Western societies having "genealogical amnesia" they are usually comparatively small networks because kin are not the most important basis for making a living, thus requiring genealogical research on bilateral/biological relations to identify more, but previously unrecognized, "*kin*."

Kinship: As defined by Murdock (1949), the general subject matter of relationships, be they social and/or biological.

Lineage: Not a collection of biological kin. A unilineal descent group (with potentially hundreds of members) whereby members trace descent with one another matrilineally (a *matrilineage*) or patrilineally (a *patrilineage*) back to founding ancestors (known or mythical), thus excluding most of each member's biological *kindred* relatives. Societies differ in corporate lineage functions: in most they collectively own property, and in nearly all they have exclusive ceremonies and provide a large group for mutual support

from, and obligations to, members (regardless of biological distance) that may not extend to biologically close members of other lineages. Unless nested within clans, the lineages are exogamous to preserve the unilineal principle of descent-based membership. Lineages commonly comprise multiple unilineal *household groups*.

Matriclan: A clan based on matrilineal descent principles for exclusive membership: see *Clan*.

Matrilineage: A lineage based on matrilineal descent principles for exclusive membership: see *Lineage*.

Matrilineal descent: The practice and ideology of tracing descent through mothers only, thus excluding fathers and all others from one's line of descent and therefore excluding the majority of biological relationships from one's line of descent.

Matrilineal descent group: a unilineal descent group (see *lineage* and *clan*) with exclusive membership dictated by the principle of *matrilineal descent*, thus excluding most of each members' biological *kin*.

Matrilineal household group: A corporate group based on matrilineal descent principles for exclusive membership: see *Household group*.

Matrilocality: A postmarital residence practice defined by a married couple's residence with the wife's mother. "Uxorilocality," specifically referencing residence with the wife's sisters, is subsumed but may exist in the absence of matrilocality.

Matrilocal residential group: A coresiding group of matrilineally-related women and children joined by their husbands who are displaced but belong to their own *matrilineal household groups* (unless men transfer their membership upon marriage) resulting from *matrilocality*. See *Residential Group*.

Neolocality: A postmarital residence practice defined by a married couple's establishment of a new home away from either spouses' *kin*. Unlike other kin groups, a non-perpetuating group that dissolves as children move away and form new neolocal residences. Commonly associated with a dependence on non-kin for making a living (e.g., wage labor or private property), and thus expanding with commercial globalization. The major form of residence emphasized in Western cultures, possibly giving rise to naturalizing and universalizing Western notions of what constitutes "*family*" and an atomizing view of *kinship* as biological relatedness.

Omaha Marriage: A patrilineal descent group-based marriage system whereby individuals and their siblings are prohibited from marrying anyone in their own exogamous patriclan (even though most members are biologically distant), their mother's patriclan (even though most members are biologically distant to mother), and in some societies their father's mother's patriclan (even though most members are biologically distant to father's mother). Marriage with members of other clans are permissible (regardless of biological distance to their members). The proscriptions disperse marriages – and gene flow – across numerous clans, inhibiting intense gene flow between two or few clans. In the absence of clans, the same rules may apply to exogamous patrilineages.

Patriclan: A clan based on patrilineal descent principles for exclusive membership: see *Clan*.

Patrilineage: A lineage based on patrilineal descent principles for exclusive membership: see *Lineage*.

Patrilineal descent: The practice and ideology of tracing descent through fathers only, thus excluding mothers and all others from one's line of descent and therefore excluding the majority of biological relationships from one's line of descent.

Patrilineal descent group: a unilineal descent group (see *lineage* and *clan*) with exclusive membership dictated by the principle of *patrilineal descent*, thus excluding most of each members' biological *kin*.

Patrilineal household group: A corporate group based on patrilineal descent principles for exclusive membership: see *Household group*.

Patrilocality: A postmarital residence practice defined by a married couple's residence with the husband's father. "Virilocality," specifically referencing residence with the husband's brothers, is subsumed but may exist in the absence of patrilocality.

Patrilocal residential group: A coresiding group of patrilineally-related men and children joined by their wives who are displaced but belong to their own *patrilineal household groups* (unless women transfer their membership upon marriage) resulting from *patrilocality*. See *Residential Group*.

Residential Group: A coresiding group of people, including affines recruited through marriage who despite dislocation remain members of their own *household group* (unless they transfer membership upon marriage). The primary function of the residential group is to reproduce and perpetuate the corporate *household group*.

Sodality: A group with any social function whose membership is not based on kinship relations.

References Cited

- Alt, Kurt W., and Werner Vach. 1995. Odontologic kinship analysis in skeletal remains: Concepts, methods, and results. *Forensic Science International* 74:99-113.
- Alt, Kurt W., and Werner Vach. 1998. Kinship studies in skeletal remains – Concepts and examples. In *Dental anthropology: Fundamentals, limits, and prospects*, Kurt W. Alt, Friedrich W. Rösing, and Maria Teschler-Nicola, eds. Pp.537-554. Wein: Springer.
- Alt, Kurt W., Sandra Pichler, Werner Vach, Bohuslav Klíma, Emanuel Vlček, and Jürg Sedlmeier. 1997. Twenty-five thousand-year-old triple burial from Dolní Věstonice: An ice-age family? *American Journal of Physical Anthropology* 102:123-131.
- Aguiar, Gilberto de Souza, and Walter Alvez Neves. 1991. Postmarital residence pattern and within-sex genetic diversity among the Urubu-Ka'apor Indians, Brazilian Amazon. *Human Biology* 63:467-488.
- Ahmed, Akbar S. 1980. *Pukhtun economy and society: traditional structure and economic development in a tribal society*. Boston: Routledge & Kegan Paul.
- Barth, Fredrik. 1965. *Political leadership among Swat Pathans*. London: The Athlone Press.
- Bastian, Misty L. 1992. *The world as marketplace: historical, cosmological, and popular constructions of the Onitsha market system*. Ann Arbor: UMI Dissertation Services.
- Beaglehole, Ernest. 1941. *Pangai: village in Tonga*. Wellington: The Polynesian Society.
- Bedrick E.J., J. Lapidus, and J.F Powell. 2000. Estimating the Mahalanobis distance from mixed continuous and discrete data. *Biometrics* 56:394–401.

- Bouwman, Abigail. 2014. The different aspects of aDNA in establishing kinship. Paper presented at the 79th Annual Meeting of the Society for American Archaeology, Austin, April 23-27.
- Carr, Christopher. 1995. Mortuary practices: their social, philosophical-religious, circumstantial, and physical determinants. *Journal of Archaeological Method and Theory* 2:105-200.
- Cole, John Tafel. 1969. *The human soul in the Aymara culture of Pumasara: an ethnographic study in the light of George Herbert Mead and Martin Buber*. Ann Arbor: University Microfilms.
- Collier, Jane F., and Sylvia J. Yanagisako, eds. 1987. *Gender and kinship: essays toward a unified analysis*. Stanford: Stanford University Press.
- De Laguna, Frederica. 1972. *Under Mount Saint Elias: the history and culture of the Yakutat Tlingit*. Washington, D.C.: Smithsonian Institution Press.
- Driver, Harold E., and William C. Massey. 1957. *Comparative studies of North American Indians*. Philadelphia: American Philosophical Society.
- Eggan, Fred. 1966. *The American Indian*. Chicago: Aldine.
- Ellison, James. 2009. Governmentality and the family: neoliberal choices and emergent kin relations in Southern Ethiopia. *American Anthropologist* 111:81-92.
- Ember, Carol R., and Melvin Ember. 1972. The conditions favoring multilocal residence. *Southwestern Journal of Anthropology* 28:382-400.
- Ember, Melvin, and Carol R. Ember. 1971. The conditions favoring matrilineal versus patrilineal residence. *American Anthropologist* 73:571-594.

- Ensor, Bradley E. 2003. Kinship and marriage among the Omaha, 1886-1902. *Ethnology* 42:1-14.
- . 2011. Kinship theory in archaeology: from critiques to the study of social transformations. *American Antiquity* 76:203-227.
- . 2013a. *The archaeology of kinship: advancing interpretation and contributions to theory*. Tucson: University of Arizona Press.
- . 2013b. *The crafting of prehispanic Maya kinship*. Tuscaloosa: University of Alabama Press.
- . 2014. Discussant - Bioarchaeological approaches to kinship: bridging biology, social relatedness, and theory. Paper presented at the 79th Annual Meeting of the Society for American Archaeology, Austin, April 23-27.
- Fenton, William N. 1951. Locality as a basic factor in the development of Iroquois social structure. *Bureau of American Ethnology Bulletin* 149:35-54.
- Filipovic, Milenko S.
- 1982 *Among the people, native Yugoslav ethnography: selected writing of Milenko S. Filipovic*. Ann Arbor: Michigan Slavic Publications, Department of Slavic Languages and Literatures.
- Fortes, Meyer. 1945. *The dynamics of clanship among the Tallensi: being the first part of an analysis of the social structure of a Trans-Volta Tribe*. London: Oxford University Press for the International African Institute.
- . 1950. Kinship and marriage among the Ashanti. In *African systems of kinship and marriage*. A. R. Radcliffe-Brown and D. Forde, eds. Pp. 252-284. London: Oxford University Press for the International African Institute,.

- . 1959. Primitive kinship. *Scientific American* 200(6):146-158.
- Fox, Robin. 1967. *Kinship and marriage: an anthropological perspective*. Cambridge: Cambridge University Press.
- Franklin, Sarah, and Susan McKinnon, eds. 2001. *Relative values: reconfiguring kinship studies*. Durham: Duke University Press.
- Gillespie, Susan D. 2000a. Beyond kinship: an introduction. In *Beyond kinship: social and material reproduction in house societies*. Rosemary A. Joyce and Susan D. Gillespie, eds. Pp. 1-21. Philadelphia: University of Pennsylvania Press.
- . 2000b. Rethinking ancient Maya social organization: replacing “lineage” with “house.” *American Anthropologist* 102:467-484.
- Gjessing, Gutorm. 1956. *Socio-culture: interdisciplinary essays on society and culture*. Oslo: Studies Honouring the Centennial of Universitetes Etnografiske Museum.
- . 1975. Socio-Arcaheology. *Current Anthropology* 16:323-341.
- Gluckman, Max. 1941. *Economy of the Central Barotse Plain*. Livingstone: The Rhodes-Livingstone Institute.
- Godelier, Maurice. 2011. *The metamorphoses of kinship*. New York: Verso.
- Goldstein, Lynn G. 1981. One-dimensional archaeology and multi-dimensional people: spatial organization and mortuary analysis. In *The archaeology of death*, Robert Chapman, Ian Kinnes, and Klavs Randsborg, eds. Pp. 53-70. Cambridge: Cambridge University Press.
- Gough, Kathleen. 1961. Variation in residence. In *Matrilineal kinship*. David M. Schneider and Kathleen Gough, eds. Pp. 545-576. Berkeley: University of California Press.

- Gutierrez de Pineda, Virginia, and Sydney J. Muirden. 1948. *Social organization in La Guajira. Bogota*. New Haven: Human Relations Area Files.
- Han, Chungnim C. 1970. *Social organization of upper Han Hamlet in Korea*. Ann Arbor: University Microfilms.
- Hirschon, Renee. 1989. *Heirs of the Greek Catastrophe: the social life of Asia Minor refugees in Piraeus*. Oxford: Oxford University Press.
- Hoffman, Bernard G. 1967. *The structure of traditional Moroccan rural society*. The Hague: Mouton & Co.
- Hough, Walter. 1899. Korean clan organization. *American Anthropologist* 1:150-154.
- Howell, Todd L., and Keith W. Kintigh. 1996. Archaeological identification of kin groups using mortuary and biological data: an example from the American Southwest. *American Antiquity* 61:537-554.
- Hubbe, Mark, Walter Alves Neves, Emiliano Castro de Oliveira, and André Strauss. 2009. Postmarital residence practice in Southern Brazilian coastal groups: continuity and change. *Latin American Antiquity* 20:267-278.
- Hulstaert, Gustave E., and Monika B. Vizedom. 1938. *Marriage among the Nkundu*. Bruxelles: Librairie Falk fils.
- Hunt, Muriel Eva Verbitsky. 1962. *The dynamics of the domestic group in two Tzeltal villages: a contrastive comparison*. Ph.D. dissertation. University of Chicago, Chicago.
- Hurault, Jean, and Jean Winchell. 1961. *The Boni refugee Blacks of French Guiana*. Dakar: IFAN.

- Hutchinson, Sharon E. 1996. *Nuer dilemmas: coping with money, war, and the state*. Berkeley: University of California Press.
- Irish Joel D. 2010. The mean measure of divergence (MMD): its utility in model-free and model-bound analyses relative to the Mahalanobis D^2 distance for nonmetric traits. *American Journal of Human Biology* 22:378–395.
- Janelli, Roger L., and Dawnhee Yim Janelli. 1982. *Ancestor worship and Korean society*. Stanford: Stanford University Press.
- Johnson, Kent, and Kathleen Paul, organizers. 2014. Bioarchaeological approaches to kinship: bridging biology, social relatedness, and theory. Abstracts of the SAA 79th Annual Meeting.
http://www.saa.org/Portals/0/SAA/Meetings/2014%20Abstracts/Session_Abstracts.pdf, (accessed July 10, 2014).
- Jones, Doug and Bojka Milicik, eds. 2011. *Kinship, language, and prehistory: Per Hage and the renaissance in kinship studies*. Salt Lake City: University of Utah Press.
- Kaut, Charles R. 1957. *The Western Apache clan system: its origins and development*. Albuquerque: University of New Mexico Press.
- Keegan, William F. 2006. All in the family: descent and succession in the protohistoric chiefdoms of the Greater Antilles - a comment on Curet. *Ethnohistory* 53:383-392.
- . 2009. Central plaza burials in Saladoid Puerto Rico: an alternative perspective. *Latin American Antiquity* 20:375-385.
- Keesing, Roger M. 1975. *Kin groups and social structure*. New York: Holt, Rinehart & Winston.

- Konigsberg, Lyle W. 1988. Migration models of prehistoric postmarital residence. *American Journal of Physical Anthropology* 77:471-482.
- . 1990. Analysis of prehistoric biological variation under a model of isolation by geographic and temporal distance. *Human Biology* 62:49–70.
- . 2006. A post-Neumann history of biological and genetic distance studies in bioarchaeology. In *Bioarchaeology: the contextual analysis of human remains*. Jane E. Buikstra and Lane A. Beck, eds. Pp. 263–279. New York: Academic Press.
- Kopytoff, Igor, Robert Mayfield, Ruth C. Heffner, and Thomas A. Sebok. 1955. *The Samoyed*. New Haven: Human Relations Area Files.
- Korotayev, Andrey. 2003. Form of marriage, sexual division of labor, and postmarital residence in cross-cultural perspective: a reconsideration. *Journal of Anthropological Research* 59:69-89.
- Kruskal, Joseph B., and Myron Wish. 1978. *Multidimensional scaling*. Beverly Hills, CA: Sage Publications.
- Lane, Rebecca A., and Audrey J. Sublett. 1972. Osteology of social organization: Residence Pattern. *American Antiquity* 37:186-201.
- Kuper, Adam. 1982. Lineage theory: a critical retrospect. *Annual Review of Anthropology* 11:71-95.
- Lévi-Strauss, Claude. 1956. The family. In *Man, culture, and society*. Harry L. Shapiro, ed. Pp. 261-285. New York: Oxford University Press.
- . 1965. The future of kinship studies. *Proceedings of the Royal Anthropological Institute of Great Britain and Ireland* 1965:13-22.

- . 1969. *The elementary structures of kinship*. Boston: Beacon Press.
- . 1982. *The way of the masks*. Seattle: University of Washington Press.
- Lutfiyya, Abdulla M. 1966. *Baytiin a Jordanian Village: a study of social institutions and social change in a folk community*. The Hague: Mouton.
- Marshall, Maureen. 2014. >Sharing death' : double interments in the Late Bronze Age South Caucasus. Paper presented at the 79th Annual Meeting of the Society for American Archaeology, Austin, April 23-27.
- McIlwraith, Thomas F. 1948. *The Bella Coola Indians: volume one*. Toronto: University of Toronto Press.
- McConvell, Patrick, Ian Keen, and Rachel Hendery, eds. 2013. *Kinship systems: change and reconstruction*. Salt Lake City: University of Utah Press.
- McKnight, David. 2004. *Going the Whiteman's way: kinship and marriage among Australian Aborigines*. Aldershot: Ashgate.
- Meyer, William. 2014. Discussant - Establishing a bioarchaeology of community. Paper presented at the 79th Annual Meeting of the Society for American Archaeology, Austin, April 23-27.
- Murdock, George P. 1949. *Social structure*. New York: Macmillan.
- Parman, Susan. 1972. *Sociocultural change in a Scottish Crofting township*. Ann Arbor: University Microfilms.
- Pasternak, Burton. 1976. *Introduction to kinship and social organization*. Englewood Cliffs: Prentice-Hall.

- Peletz, Michael G. 1995. Kinship studies in Late Twentieth-Century anthropology. *Annual Review of Anthropology* 24:343-372.
- Peregrine, Peter N. 2001. Matrilocality, corporate strategy, and the organization of production in the Chacoan world. *American Antiquity* 66:36-46.
- Peregrine, Peter N., and Melvin Ember. 2002. Response to Schillaci and Stojanowski. *American Antiquity* 67:357-359.
- Price, Richard. 1975. *Saramaka social structure: analysis of a maroon society in Surinam*. Rio Piedras: Institute of Caribbean Studies, University of Puerto Rico.
- Prokof'eva, E. D., Maksim G. Levin, and Leonid P. Potapov. 1964. The Nentsy. In *The peoples of Siberia*. Maksim G. Levin and Leonid P. Potapov, eds. Pp. 547-570. Chicago: University of Chicago Press.
- Rattray, Robert S. 1929. *Ashanti law and constitution*. Oxford: Clarendon Press.
- Relethford, John H., and J. Blangero. 1990. Detection of differential gene flow from patterns of quantitative variation. *Human Biology* 62:5-25.
- Relethford, John H., and F. C. Lees. 1982. The use of quantitative traits in the study of human population structure. *Yearbook of Physical Anthropology* 25:113-132.
- Saxe, Arthur A. 1970. *Social dimensions of mortuary practices in a Mesolithic population from Wadi Halfa, Sudan*. Ph.D. dissertation, University of Michigan, Ann Arbor.
- Sahlins, Marshall D. 2013. *What kinship is - and is not*. Chicago: The University of Chicago Press.
- Scheffler, Harold W. 2001. *Filiation and affiliation*. Boulder: Westview Press.

- Schillaci, Michael A., and Christopher M. Stojanowski. 2002. A reassessment of matrilocality in Chacoan culture. *American Antiquity* 67:343-356.
- . 2003. Postmarital residence and biological variation at Pueblo Bonito. *American Journal of Physical Anthropology* 120:1-15.
- Schneider, David M. 1984. *A critique of the study of kinship*. Ann Arbor: University of Michigan Press.
- Schram, Louis. 1932. *Marriage among the T'u-jen of Kansu (China)*. Shanghai: Catholic Mission Press.
- . 1954. *The Monguors of the Kansu-Tibetan frontier: their origin, history and social organization*. Philadelphia: American Philosophical Society.
- Scott, G. Richard, and Christy G. Turner II. 1997. *The anthropology of modern human teeth: dental morphology and its variation in recent human populations*. Cambridge: Cambridge University Press.
- Seidel, Andrew, and Kristin Nado. 2014. Changing conceptualizations of kinship among the Post-Meroitic and Christian period Nubians from the 4th Cataract Region, Sudan. Paper presented at the 79th Annual Meeting of the Society for American Archaeology, Austin, April 23-27.
- Shternberg, Lev I. A. 1933. *The Gilyak, Orochi, Goldi, Negidal, Ainu: articles and materials*. Khabarovsk: Dal'giz.
- Sjøvold T. 1977. Non-metrical divergence between skeletal populations: the theoretical foundation and biological importance of C.A.B. Smith's mean measure of divergence. *Ossa Supplement* 4 1:1-133.

- Spence, Michael W. 1974. Residential Practices and the Distribution of Skeletal Traits in Teotihuacan, Mexico. *Man* 9:262-273.
- Stefan, Vincent H. 1999. Craniometric variation and homogeneity in prehistoric/protohistoric Rapa Nui (Eastern Island) regional populations. *American Journal of Physical Anthropology* 110:407-419.
- Stojanowski, Christopher M., and Michael A. Schillaci. 2006. Phenotypic approaches for understanding patterns of intracemetery biological variation. *Yearbook of Physical Anthropology* 49:49-88.
- Stout, David B. 1947. *San Blas Cuna acculturation: an introduction*. New York: The Viking Fund.
- Tomczack, Paula D., and Joseph F. Powell. 2003. Postmarital residence practices in the Windover population: sex-based dental variation as an indicator of patrilocality. *American Antiquity* 68:93-108.
- Usher, Bethany, and Jaimin Weets. 2014. Identifying kinship patterns in Anabaptist cemeteries: modeling archaeological graveyards. Paper presented at the 79th Annual Meeting of the Society for American Archaeology, Austin, April 23-27.
- Wedgwood, Camilla H. 1943. Notes on the Marshall Islands. *Oceania* 13:1-23.
- Zakrzewski, Sonia. 2014. Kinship, identity, and ancient Egyptian bioarchaeological relatedness. Paper presented at the 79th Annual Meeting of the Society for American Archaeology, Austin, April 23-27.

Table 1. Sample of 28 cultures, illustrating cemetery organization and postmortem location by kinship strategy.

| Descent/Descent Groups | Cemetery and Postmortem Location | Cultures |
|---|---|---|
| Matrilineal descent groups | In natal matrilineal descent group cemetery: men are returned to their group's cemetery despite matrilocality. | Iroquois in the 1930s-1940s (Fenton 1951) Akan (Ashante) in the 1920s-1940s(Fortes 1950; Rattray 1929) Saramaka in the 1960s (Price 1975) Goajiro in the 1940s (Gutierrez de Pineda and Muirden 1948) Marshallese in the 1930s (Wedgwood 1943) Western Apache (Cibecue) in the 19 th century to 1950s(Kaut 1957) Tlingit from the 18 th to 20 th centuries (De Laguna 1972) Ndyuka in the 1940s-1950s (Hurault and Winchell 1961) |
| Patrilineal descent groups, whereby women maintain membership in their natal group. | In natal patrilineal descent group cemetery: women are returned to their group's cemetery despite patrilocality. | Tallensi (Fortes 1945) |
| Patrilineal descent groups, whereby women's membership is transferred to husbands' groups | In men's patrilineal descent group cemetery (includes both spouses) | Shluh (Hoffman 1967) Pashtun in the 1950s-1970s (Ahmed 1980; Barth 1965) Korean rural lineages in the 19 th century to 1970s (Han 1970; Hough 1899; Janelli and Janelli 1982) Monguor in the 1910s-1940s (Schram 1942, 1954) Serbs in the 20 th century (Filipovic 1982) Palestinians in 1960 (Lutfiyya 1966) |
| Patrilineal descent groups | In patrilineal descent group cemeteries, but no ethnographer's statement regarding the membership and burial locations for married women. | Mongol in the 1930s (Hulstaert and Vizedom 1938) Igbo (Bastian 1992) Nenets in the 19 th century (Prokof'eva et al. 1964) Nivkh in the 19 th century (Shternberg 1933) Samoyed in the 19 th century (Kopytoff et al. 1955) Aymara in the 1950s (Cole 1969) |

Table 1. Sample of 28 cultures, illustrating cemetery organization and postmortem location by kinship strategy.

| Descent/Descent Groups | Cemetery and Postmortem Location | Cultures |
|-------------------------------|--|---|
| Bilateral descent | In cemetery used by residential groups (includes both spouses), regardless of type of postmarital residence. | Lozi - bilocal postmarital residence (Gluckman 1941) Highland Scots in the 1970s - neolocal postmarital residence (Parman 1972) Greek refugees in the 1980s - neolocal postmarital residence (Hirschon 1989) Cuna - matrilocal postmarital residence (Stout 1947) Bella Coola - patrilocal postmarital residence (McIlwraith 1948) Tzeltal in the 1950s - patrilocal postmarital residence (Hunt 1962) Tongan commoners in the 1930s - patrilocal postmarital residence (Beaglehole 1941) |

| Table 2. Summary of phenotype biodistance expectations for cemetery populations and their interpretation. | | |
|---|--|---|
| Phenotypic Distance | Phenotypic Distance Between Adult Sexes | Social Organization |
| LARGE CEMETERIES | | |
| Multiple statistical clusters of few adult males and females, with high inter-cluster distances | No significant differences between pooled males and pooled females | Matrilineages or Matriclans Patrilineages or Patriclans |
| Multiple statistical clusters of few adult males, with high inter-cluster distances | Significant differences between pooled males and pooled females, and greater heterogeneity among females | Patrilineages or Patriclans, with transfer of wives' membership to husbands' groups |
| Multiple statistical clusters of few adult males and females, with a continuum of inter-cluster distances (low to high) | No significant differences between pooled males and pooled females | Bilateral descent combined with bilocality or with neolocality |
| Multiple statistical clusters of few adult females, with a continuum of inter-cluster distances (low to high) | Significant differences between pooled males and pooled females, and greater heterogeneity among females | Bilateral descent combined with matrilocality |
| Multiple statistical clusters of few adult males, with a continuum of inter-cluster distances (low to high) | Significant differences between pooled males and pooled females, and greater heterogeneity among females | Bilateral descent combined with patrilocality |
| SMALL HOUSEHOLD-SCALE CEMETERIES | | |
| Homogeneity among adult males and females | No significant differences between pooled males and pooled females | Matrilineal or patrilineal household group cemetery within larger matrilineal or patrilineal descent groups |

| Table 2. Summary of phenotype biodistance expectations for cemetery populations and their interpretation. | | |
|--|--|--|
| Phenotypic Distance | Phenotypic Distance Between Adult Sexes | Social Organization |
| Homogeneity among adult males | Significant differences between pooled males and pooled females, and greater heterogeneity among females | Patrilineal household group cemetery within larger patrilineal descent group, with transfer of wives' membership to husbands' groups |
| Homogeneity among some adult males and females, with some heterogeneity | No significant differences between pooled males and pooled females | Bilocal residential-household group under bilateral descent |
| Homogeneity among adult females | Significant differences between pooled males and pooled females, and greater heterogeneity among males | Matrilocal household group cemetery under bilateral descent |
| Homogeneity among adult males | Significant differences between pooled males and pooled females, and greater heterogeneity among females | Patrilocal household group cemetery under bilateral descent |

Table 3. Hypothetical illustration of how sibling sets share and spread alleles across clans in a Crow Marriage System. Existing gene flow among Clan A members and members of other clans is indicated by F (father's clan) and MF (mother's father's clan), in which siblings cannot seek spouses. Marriages are permitted with members of other clans enabling new, additional gene flow across clans.

| Clan A Sibling Sets | Clan B | Clan C | Clan D | Clan E | Clan F | Marriage Prohibition Implications |
|---------------------|--------|--------|--------|--------|--------|--|
| 1: men | | | F | | MF | Children belonging to (and buried with) Clan B, C, or E will obtain alleles from Clan A members. |
| 1: women | | | F | | MF | Clan A children will obtain alleles from a husband belonging to (and buried with) Clan B, C, or E. |
| 2: men | MF | F | | | | Children belonging to (and buried with) Clan D, E, or F will obtain alleles from Clan A members. |
| 2: women | MF | F | | | | Clan A children will obtain alleles from a husband belonging to (and buried with) Clan D, E, or F. |
| 3: men | F | | MF | | | Children belonging to (and buried with) Clan C, E, or F will obtain alleles from Clan A members. |
| 3: women | F | | MF | | | Clan A children will obtain alleles from a husband belonging to (and buried with) Clan C, E, or F. |
| 4: men | | MF | | F | | Children belonging to (and buried with) Clan B, D, or F will obtain alleles from Clan A members. |
| 4: women | | MF | | F | | Clan A children will obtain alleles from a husband belonging to (and buried with) Clan B, D, or F. |
| 5: men | | | | F | MF | Children belonging to (and buried with) Clan B, C, or D will obtain alleles from Clan A members. |

| | | | | | | |
|----------|--|--|--|---|----|--|
| 5: women | | | | F | MF | Clan A children will obtain alleles from a husband belonging to (and buried with) Clan B, C, or D. |
|----------|--|--|--|---|----|--|

Figure Captions

Figure 1. Diagram of a biologically-related collection of individuals. Only those shaded belong to one matrilineage. Those not shaded belong to a number of additional matrilineages and would be buried in different cemeteries. Some members of the shaded matrilineage are closely related biologically whereas other members have distant biological relations. Regardless, the men and women of that matrilineage should be buried together in the same cemetery, resulting in multiple small clusters of men and women with low biodistances but with greater intercluster biodistances. Meanwhile, some close biological relations belong to completely different lineages, resulting in low biodistances among small clusters among different lineage cemeteries.

Figure 2. Idealized expectations for MDS plots of individuals in large cemeteries for A) a matrilineal descent group, B) a patrilineal descent group without wives' transfer of membership, C) a patrilineal descent group with wives' transferred membership, D) multiple bilocal residential-household groups under bilateral descent, E) multiple matrilocal residential groups under bilateral descent, and F) multiple patrilocal residential groups under bilateral descent.

Figure 1

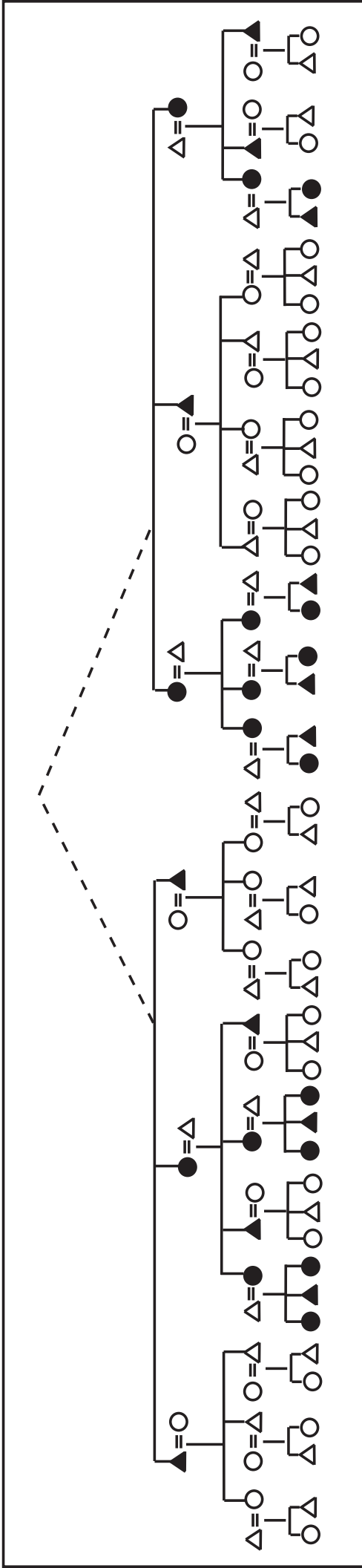
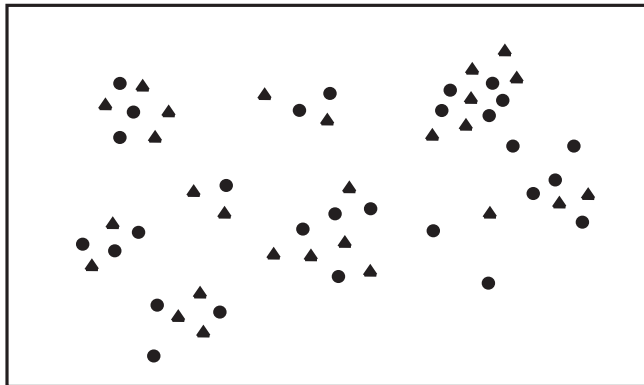
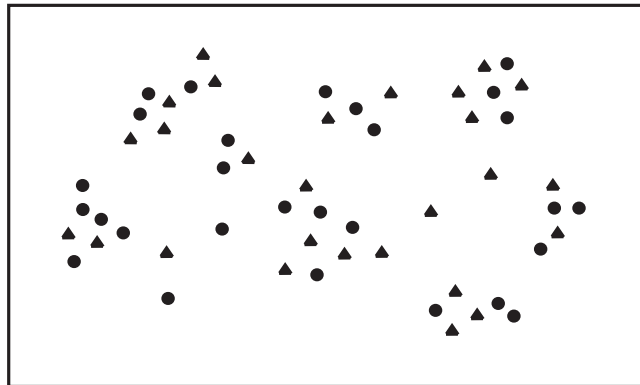

Figure 2



A



B

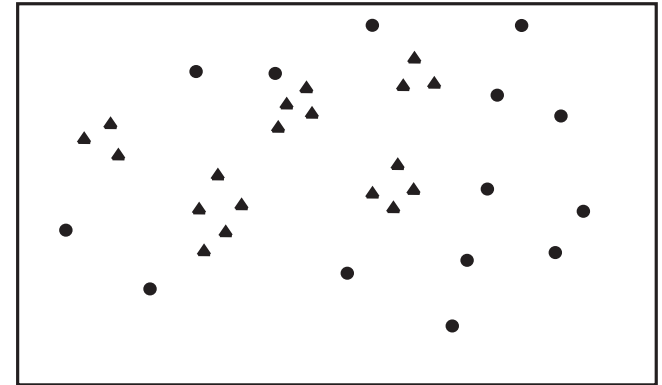

C

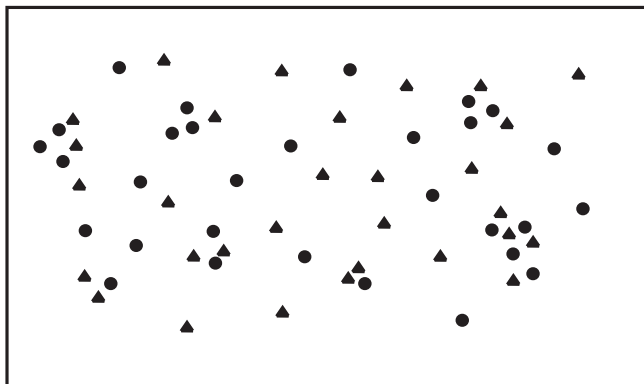

D

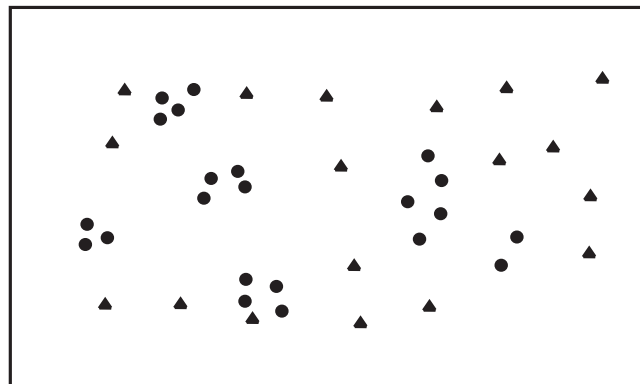

E

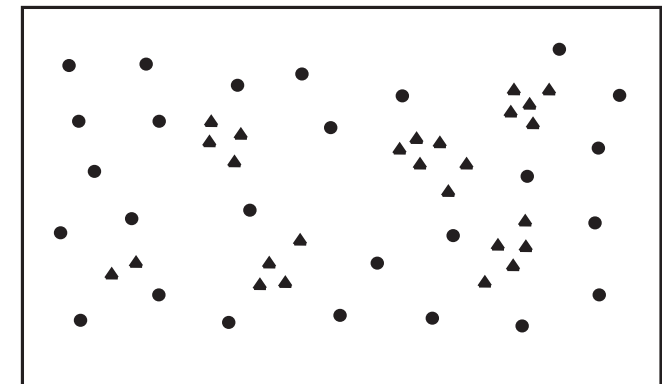

F

● Female ▲ Male