



LJMU Research Online

Setiadi, H and Jones, KO

Power system design using firefly algorithm for dynamic stability enhancement

<http://researchonline.ljmu.ac.uk/id/eprint/6603/>

Article

Citation (please note it is advisable to refer to the publisher's version if you intend to cite from this work)

Setiadi, H and Jones, KO (2016) Power system design using firefly algorithm for dynamic stability enhancement. Indonesian Journal of Electrical Engineering and Computer Science, 1 (3). pp. 446-455. ISSN 2502-4752

LJMU has developed **LJMU Research Online** for users to access the research output of the University more effectively. Copyright © and Moral Rights for the papers on this site are retained by the individual authors and/or other copyright owners. Users may download and/or print one copy of any article(s) in LJMU Research Online to facilitate their private study or for non-commercial research. You may not engage in further distribution of the material or use it for any profit-making activities or any commercial gain.

The version presented here may differ from the published version or from the version of the record. Please see the repository URL above for details on accessing the published version and note that access may require a subscription.

For more information please contact researchonline@ljmu.ac.uk

<http://researchonline.ljmu.ac.uk/>

Power System Design using Firefly Algorithm for Dynamic Stability Enhancement

Herlambang Setiadi*, Karl O Jones

Department of Electronics and Electrical Engineering,
Liverpool John Moores University, Byrom Street, Liverpool L3 3AE, United Kingdom
e-mail: herlambang2345@gmail.com

Abstract

Utilising additional devices in power systems have been developed by industry. Devices such as a Power System Stabilizer (PSS) and a Superconducting Magnetic Energy Storage (SMES) are commonly employed in industry. This work investigated the coordination of a PSS and SMES applied to a power system to enhance dynamic stability. To obtain optimal coordination, the parameters of the PSS and SMES are tuned using the Firefly Algorithm (FA). The simulation of the power system, PSS, and SMES has been performed using MATLAB and Simulink, and the FA run in Matlab. For testing the small signal stability, the eigenvalue of the system will be investigated, while for dynamic stability the system will be given an external disturbance. The rotor angle and frequency deviation of the power system are compared without a controller, with a PSS and SMES included, and with the PSS and SMES tuned by FA. The simulation results show that the proposed system can improve not only small signal stability (steady state stability) but also dynamic stability.

Keywords: Power System Stabilizer, Superconducting Magnetic Energy Storage, Firefly Algorithm, Dynamic Stability

1. Introduction

Electricity demand in recent times has become a liability and is more than likely to increase rapidly in the future. This growing demand for power requires electricity providers to increase their generating capacity and to expand their distribution network, thus making the entire system large. On large systems there are common problems associated with system stability. Disturbances that affect the stability of the system can be transient disturbance or dynamic disturbance. Large transient disturbance is one that occurs as a result of a broken transmission line, whilst dynamical disturbances are minor ones, such as load changes [1].

In the case of dynamic stability, the system is often impaired owing to the effect of load changes, which cause the system to have frequency oscillation. According to Goshal [2] the oscillation frequency that occurs is relatively low, and within range of 0.2 to 0.3 Hz. If this oscillation not well damped, magnitude of these oscillation may keep growing until system loss synchronism. To overcome these problems, additional control equipment should be installed on the system, where the Power System Stabilizer (PSS) [3] is one approach that is often used. PSS is an additional control device which serves to dampen the oscillation frequency and voltage on the generator. Since the system is larger, the PSS on its own is not enough to overcome the problem, hence other devices such as energy storage systems are required. In this era, there are a lot of energy storage approaches that have been employed, systems such as Battery Energy Storage (BES) [4, 5, 6], Redox Flow Batteries (RFB) [7, 8], Capacitive Energy Storage (CES) [6, 9] and Superconducting Magnetic Energy Storage (SMES) [6, 10-13]. SMES is one energy storage approach that is commonly used in a power plant that gives active power temporary in the load. In Ansari and Velusami [13] SMES has been used to improve the performance of a wind-diesel hybrid power system.

The use of additional equipment on the electric power system such as PSS and SMES that is not appropriate in stabilizing the system can lead to issues. The problems often arise owing to errors in taking the reference signal, or the parameters of the devices are not optimal. Adding a controller that increases system performance can make the system more unstable. Owing to these issues, an optimization method should be used to overcome the problems.

Nature always give us inspiration, and there are a number of computation or iteration methods inspired from the apparent intelligence shown in nature [14]. Smart computation can

be categorized into three groups: physically inspired such as the Simulated Annealing Algorithm; social inspired like the Tabu Search Algorithm, or Imperialist Competitive Algorithm, and lastly biologically inspired approaches such as Genetic Algorithms, Particle Swarm Optimization, Artificial Immune System, Ant Colony Optimization, Bat Algorithm and the Firefly Algorithm [14]. The Firefly Algorithm is one of the newer nature inspired algorithms, and is inspired by the behaviour of fireflies. Application of the Firefly Algorithm (FA) in optimization of power systems have been developed. There are a number of applications such as in the research of Niknam [15]. In that research a FA is used to find the optimal generation level for a power system, achieving the lowest price with a reserve constraint. Another application of the FA is as a tool to tune the parameters of a PI controller applied to speed control of a DC series motor [16]. The Firefly Algorithm has been used to address the economic emissions in a power system [17]. The FA has not only been used in power systems but also in cultivation control, for example Roeva O, Slavov [18] used a FA to tune a PID controller for glucose concentration control. All of the research proven that FA is one of the metaheuristic algorithm that very good to solve optimization problem.

Some research have been proposed to solve dynamic stability enhancement. Like in Parimi and friends research [19], they try to enhance power system stability by using one of Flexible Alternating Current Transmissions System (FACTS) devices called Interline Power Flow Controller (IPFC). Another research to enhance dynamic stability of power system have proposed by Mohammad Kashki [20], they try to improve dynamic stability in power system by combining PSS and one FACT devices called Static Phase Shifter (SPS). Kashki used Combinatorial Discrete and Continuous Action Reinforcement Learning Automata to tune PSS and SPS parameter.

Usman research [21], try to enhance the stability by controlling excitation system of power system using Automatic Voltage Regulator (AVR) combine by PSS, this time Particle Swarm Optimization have used by them to optimized parameter of AVR and PSS. Different from others, Hakim and friends [22], try to improve dynamic stability by designing PSS based of Fuzzy PID. They combine 2 Artificial Inteligent which were Fuzzy and Genetic Algorithm.

This research proposed in volves the coordination of a Power System Stabilizer (PSS) and an energy storage device called s Superconducting Magnetic Energy Storage (SMES), to improve the dynamic stability of a power system. To get improved performance of the devices, the parameters of the PSS and SMES will be tuned using one of the nature inspired algorithms, namely the Firefly Algorithm (FA). To find the best solution the objective function utilised within the Firefly Algorithm is the Comperhensive Damping Index (CDI). It is expected that by using this method the dynamic stability of the power system can be enhanced.

2. Research Method

2.1. Power System Model

Generally the power plant system can be described as shown in Figure 1. The governor is a part of a generating unit that serves to regulate the provision of fuel (steam or water) in the generating system in order to obtain a stable rotor speed. If there is a change at the ouput of the generator owing to a load change, then there will be a feedback function that is set by the governor to readjust the rotation of the rotor.

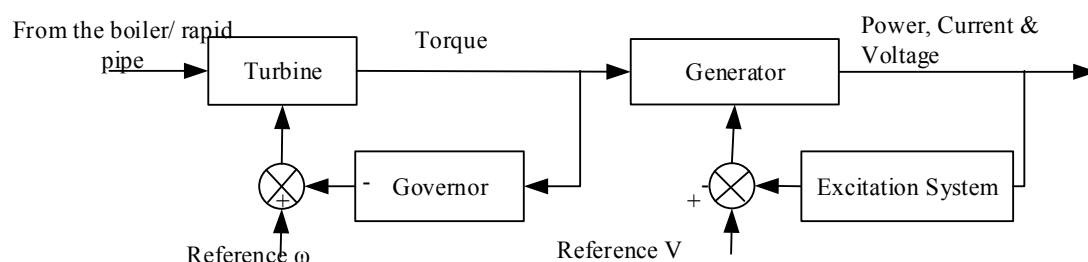

Figure 1. General Power Plant Model

The excitation system is a control system for the generator output, such as voltage, current or power factor. If there is a change in the generator output, then the excitation system serves to control the generator in order to adjust and find a new balance point. Both parts of the control system, the governor and the excitation systems, have different response times. The governor has a slow response, while the excitation system has a fast response. In the work presented here, the power system model that will be used is one that is connected to the infinite bus. The power system will be modelled in Laplace domain as shown in Figure 2. This model first introduced in [23] journal, and now this model is commonly used to solve the small signal stability and dynamic stability because in this model power systems have been modeled to a linear model. All of the values in this model are assumed in per unit values. So this model is limited in per unit values, there are no var, watt, ampere, or voltage values.

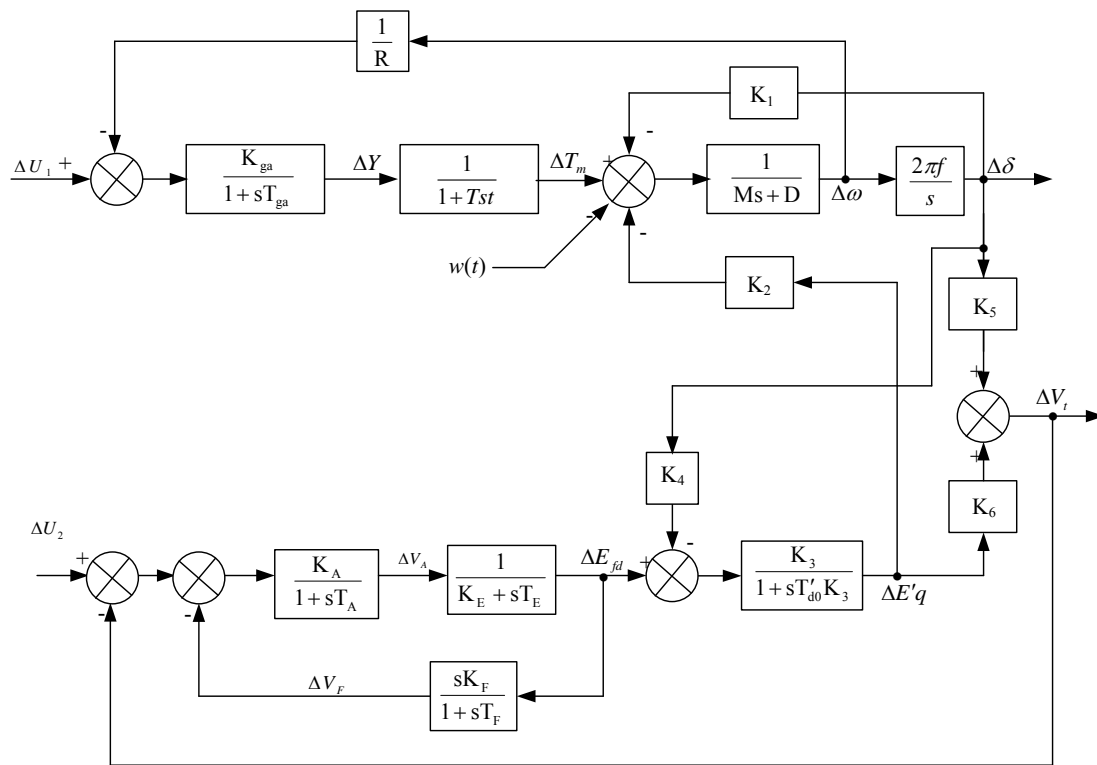

Figure 2. Power System Dynamic Model (Taken from [24])

2.2. Power System Stabilizer

The block diagram of the Power System Stabilizer (PSS) is shown in Figure 3. The PSS block diagram consists of a gain block, washout block, two blocks of lead-lag and a limiter. The block gain function is to adjust the amount of reinforcement that is obtained in accordance with the desired torque. The washout block serves to provide a steady state bias output PSS that will modify the terminal voltage of the generator. The PSS is expected to only respond to the transient variation of the rotor speed signal to the signal generator and DC offset [25].

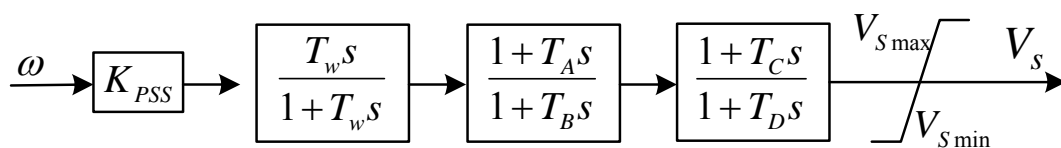

Figure 3. Block Diagram of PSS (Taken from [25])

The lead-lag functions as phase-lead producing characteristics appropriate to compensate for the phase lag between the input excitation and torque generator. The limiter function is restricts the PSS action on the AVRS. For example, in the event of load shedding, the AVR acts to reduce the terminal voltage of the generator when the PSS generates a control signal to raise the voltage (because the generator rotor speed increase in size during load shedding). In this condition it is necessary to disable the PSS. It should be noted that, the high negative limit values can disrupt the stability of the first swing [25].

2.3. Superconducting Magnetic Energy Storage

A Superconducting Magnetic Energy Storage (SMES) system within an electric power system is used to control the balance of power in the synchronous generator during periods of dynamic change. The SMES is installed in terminal bus generator on the model of the power system, as shown in the block diagram of Figure 4. All of the calculation in here asum and limit and Laplace domain.

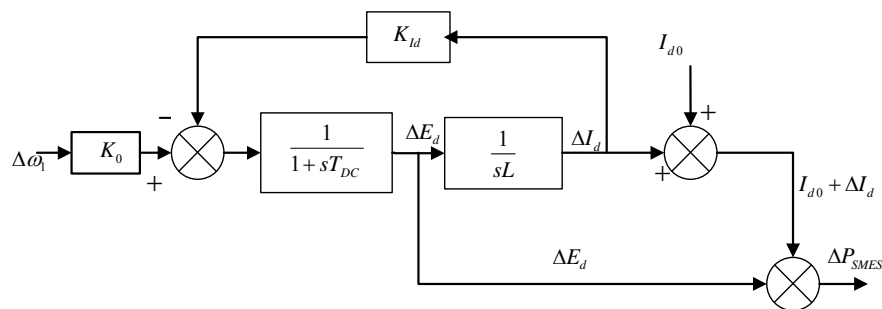

Figure 4. Block Diagram of SMES (Taken from [8] and [13])

The state variable equation of the SMES unit may be expressed as follows by inspection of the block diagram shown in Figure 4 [12]:

$$\Delta E_d = \frac{1}{1 + T_{dc}s} [k_0 \Delta \omega_1 - k_{I_d} \Delta I_d] \quad (1)$$

$$\Delta I_d = \frac{1}{Ls} \Delta E_d \quad (2)$$

Where ΔE_d is DC voltage applied to the inductor, $\Delta \omega_1$ is the rotor deviation, ΔI_d is the current flowing through the inductor, k_{I_d} is the gain for feedback ΔI_d , T_{dc} is the converter time delay, k_0 is a gain constant and L is the inductance of the coil. The deviation in the inductor real power of the SMES unit is expressed in the time domain as follows [12]:

$$\Delta P_{smes}(t) = \Delta I_{d0} \Delta E_d + \Delta I_d \Delta E_d \quad (3)$$

$\Delta P_{smes}(t)$ is the real power that will be given to the grid. The energy stored in the SMES at any instant in time, $W_{smes}(t)$, is given by [12]:

$$W_{smes}(t) = \frac{L I_d^2}{2} \quad (4)$$

2.4. Firefly Algorithm

Firefly Algorithm is a nature inspired algorithm that derives from the characteristics of fireflies. This algorithm was defined by Dr Xin-She Yang from the Univeristy of Cambridge, UK in 2008. In this algorithm there are three baseline considerations. All of the fireflies are unisex so that a firefly will be attracted to any other firefly regardless of gender [26]. The attractiveness

is proportional to the brightness of a firefly's flickering light. Therefore, for every two firefly's blinking, one of them would move to another light. Their brightness decreases as the distance between the fireflies increases. If there is no brightest firefly within the population, then all fireflies will move randomly [27]. The brightness of a firefly is influenced or determined by the objective function [27].

The objective function used to test the system is the Comprehensive Damping Index (CDI) [28, 29]. Furthermore the dynamic model of power system will be converted into state matrix in equation (5) and (6). By using the state matrix is easier to find the eigenvalues of a higher order system, the eigenvalue itself can be presented as equation (7). To find the damping value, then equation (8) is used. Finally the CDI objective function can be determined by equation (9). The variable that will be optimized by the FA is the PSS parameter and SMES parameter, there will be range of value of each parameter. The reason why this parameter is chosen is because it represents the PSS and SMES value.

$$\Delta \dot{x} = \mathbf{A}\Delta x + \mathbf{B}\Delta u \quad (5)$$

$$\Delta y = \mathbf{C}\Delta x + \mathbf{D}\Delta u \quad (6)$$

Where $\Delta \dot{x}$ is state matrix, Δy is the output variable matrix, u is the input matrix, A is the system matrix, B is the input matrix, C is the measurement matrix, and D is the input to the output matrix.

$$\lambda_i = \sigma_i + j\Omega_i \quad (7)$$

$$\xi_i = \frac{\sigma_i}{\sqrt{\sigma_i^2 + \Omega_i^2}} \quad (8)$$

$$CDI = \sum_{i=1}^n (1 - \xi_i) \quad (9)$$

Where λ_i is the eigenvalue, σ_i is the real component of the eigenvalue, Ω_i is the imaginary component of the eigenvalue, and ξ_i is the damping ratio of the system.

3. Results and Analysis

Simulation was performed using MATLAB 2010, where the power system dynamic model, Power System Stabilizer (PSS) and Superconducting Magnetic Energy Storage (SMES) were created within Simulink. The Firefly Algorithm (FA) was implemented using an M-file. Results and analysis are presented in two sections, first section shows the eigenvalue analysis and results, while the second section provides information about the dynamic performance of the system by showing the frequency and rotor angle response. Table 1 provides the parameters of the PSS and SMES that were optimized using the FA, while Figure 5 shows the convergence graph for the Firefly Algorithm (FA) as it finds the optimal value, or meets the criterion of the objective function.

Table 1. Optimized Parameters

Variable	Value
Kpss	9.9803
Tw	10.5
T1	0.465
T2	0.2965
T3	0.3845
T4	0.2257
Ko	60
Kid	5.9143

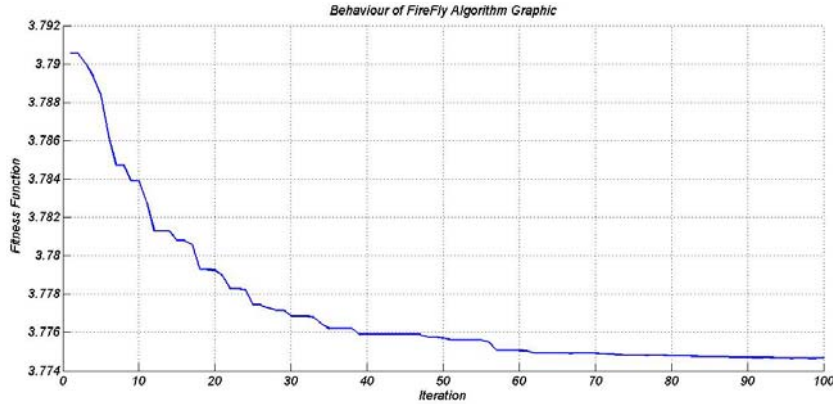

Figure 5. Convergence of the Firefly Algorithm

3.1. Small Signal Stability Analysis

Small signal stability usually called steady state stability [1], relates to the stability of the system where there are no external disturbance, or the stability of the system itself. This stability is very important is because by finding this stability, we can know wheter this system is stable or not, if we know the system is stable than we can start to run the system.

The stability of the system can be determined by finding the eigenvalue of the system. If the real parts of the eigenvalue are negative then the system is stable.

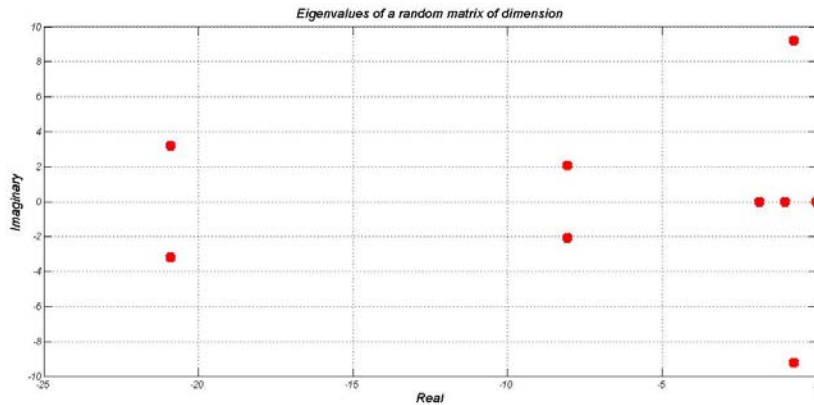

Figure 6. Eigenvalue Plot for Uncontrolled System

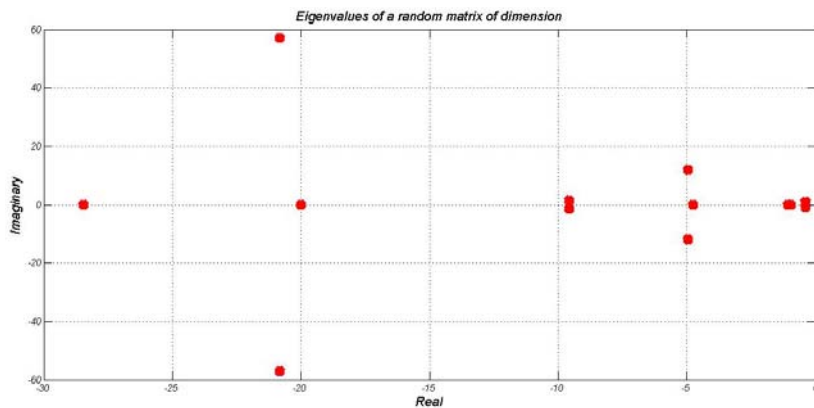

Figure 7. Eigenvalue Plot for System with PSS and SMES (Conventional)

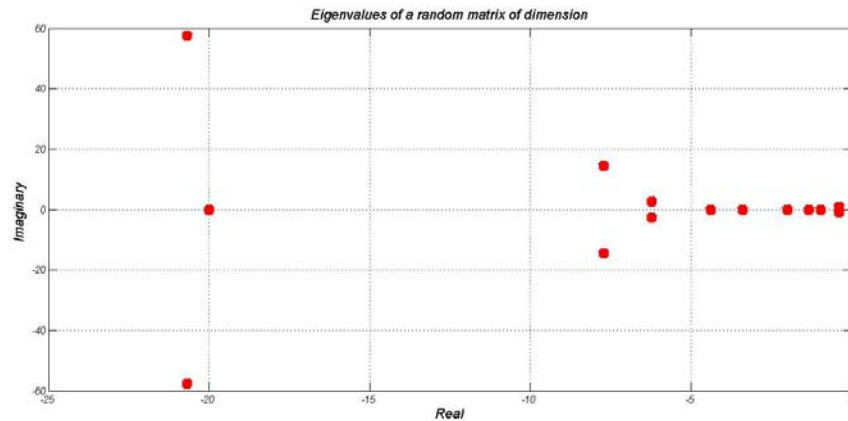

Figure 8. Eigenvalue Plot for System with FA Tuned PSS and SMES

Figures 6 to 8 show the eigenvalue plot for the system without a controller, the system with conventional PSS and SMES, and the system with PSS and SMES tuned by the FA respectively. Based on [1] the system can be called stable if the real parts of the eigenvalue are negative, where the larger the magnitude then the faster the stability. From Figure 6, it can be seen that the system without a controller is in itself stable. However, for an improved performance, the system needs to have more negative magnitude. Figures 7 and 8 show that the stability of the system increases when the system has the PSS and SMES installed. Futhermore, enhanced results are obtained when the PSS and SMES have their parameters tuned by the FA.

Another important parameter for stability is the damping ratio. If the damping ratio has a negative value then there will be a positive eigenvalue that will make the system unstable. According to Rogers [30], a power system with damping ratio greater than 0.05 is satisfactory. For this work all of the damping ratio values are greater than 0.05, as shown in figure 6 to 8. By installing the PID and SMES in the power system, the damping ratio of the system is increased: the higher the damping ratio then the oscillation level decays.

3.2. Dynamic Stability Analysis

Dynamic stability is the ability of the system to maintain a synchronised condition after the first swing happens until the system reaches a new equilibrium steady state condition [31]. This stability is where there is an external disturbance such as load change.

To analyse the dynamic behaviour of the power system, the system needs to be modelled into a linear model (that is through Laplace transformation) and given a load change 0.01 pu: the reason why 0.01 is chosen because 0.01-0.05 pu is the normal way to simulate the load changing in power system. In this simulation the load change is represented as a step signal in Simulink, where the final value of the step signal is 0.01 pu. Analysis is conducted through comparing the frequency response and rotor angle response of the power system without controller, with the inclusion of a PSS and SMES, and also with the PSS and SMES tuned by the FA. Figures 9 and 10 show the frequency response and rotor angle of the power system for all three configurations, while Tables 5 and 6 illustrate the overshoot and settling time for both frequency and rotor angle for the three system arrangements.

Table 5. Comparision Response Frequency Value

Parameter	Uncontrolled	PSS SMES	PSS SMES (FA tuned)
Overshoot (pu)	-8.622e5	-6.46e5	-5.743e5
Settling Time (Sec)	11.57	7.53	5.33

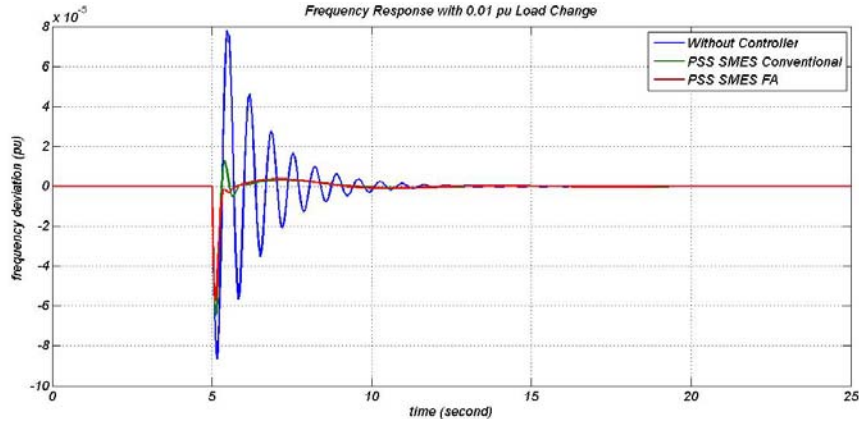

Figure 9. Frequency Response Comparison

Table 6. Rotor Angle Value Comparison Response

Parameter	Uncontrolled	PSS SMES	PSS SMES (FA tuned)
Overshoot (pu)	-0.0055	-0.0036	-0.0036
Settling Time (Sec)	12.21	14.33	13.53

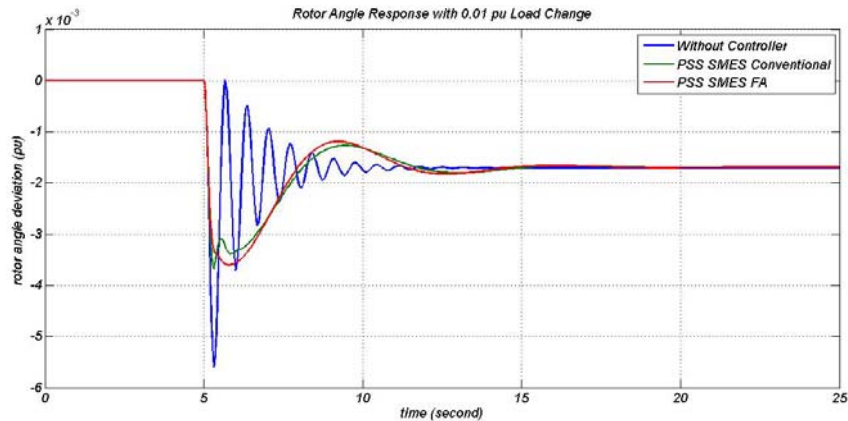

Figure 10. Rotor Angle Response Comparison

Tables 5 and 6 show that PSS and SMES can decrease the overshoot and reduce the settling time of the frequency and the rotor angle in a power system. The best result for the frequency response is that when the PSS and SMES is tuned by the FA. When the system is installed with the PSS and SMES then the system overshoot is reduced to 0.00002979 pu and the settling time is 6.24 seconds, which is faster than the system without a controller. For the rotor angle, the system including the PSS and SMES can dampen the overshoot, however the time settling is larger than that for the system without a controller. As shown in the graph, the system without a controller has quite an oscillatory response which is not appropriate because if this oscillation rises again and again, then the system will be out of synchronization and it will collapse. That is why using an additional controller is required. The PSS is used to control the excitation of the power system and the SMES works as energy storage to help the governor. Owing to that response frequency and rotor angle is better than system without controller. The FA itself helps an engineer to find the best parameter of the system: that is why the system with a PSS and SMES tuned by the FA have the best parameters.

4. Conclusion

Including a Power System Stabilizer (PSS) and Superconducting Magnetic Energy Storage (SMES) can improve the eigenvalue of a power system, thus making the overall system more stable. As well as the eigenvalue, the dynamic stability of the power system improves when the system has the PSS and SMES installed, as shown in the response of the frequency and rotor angle. The Firefly Algorithm (FA) can be employed to tune the PSS and SMES parameters so that it is easier to find the more appropriate values, although the FA itself might never find the best parameter as the FA is a stochastic method. The simulation results show that the system without a controller have high oscillation levels that continue for quite a long time. This is not good for the rotor of the generator and also not advantageous for the prime mover: the generator could go out of synchronization, while the prime mover (turbine) could break. That is why the inclusion of an additional controller is needed. In this work that fact is clearly shown.

Acknowledgment

The first author is very grateful to the Indonesian Government, especially the Directorate General of Higher Education for the Competitive Scholarship awarded to him during his studies for an MSc in Electrical Power and Control Engineering, at Liverpool John Moores University, UK. Special thanks to the second author, Dr Karl O Jones, who was the Supervisor that helped the first author tremendously.

References

- [1] Kundur P. *Power System Stability and Control*. New York: McGraw-Hill. 1994.
- [2] Goshal SP, Chatterje A and Mukherjee V. Bio-inspired fuzzy logic based tuning of power system stabilizer. *Expert System with Applications*. 2009; 36; 9281-9292.
- [3] Soni PB, Saxena A and Gupta V. A Minimax Polynomial Approximation Objective Function Approach for Optimal Design of Power System Stabilizer by Embedding Particle Swarm Optimization. *TELKOMNIKA Indonesian Journal of Electrical Engineering*. 2015; 14(2); 191-198.
- [4] Lu FC, Liu CC and Wu JC. Effect of Battery Energy Storage System on Load Frequency Control Considering Governor Deadband and Generation Rate Constraint. *IEEE Transaction on Energy Conversion*. 1995; 10(3); 555-561
- [5] Kalyani S, Nagalakshmi S and Marisha R. *Load Frequency Control using Battery Energy Storage System in Interconnected Power System*. Proceedings of ICCCNT'12. Coimbatore India. 2012.
- [6] Mahto T and Mukherjee V. Energy Storage Systems for Mitigating the Variability of Isolated Hybrid Power System. *Elsevier Renewable and Sustainable Energy Reviews*. 2015; 51; 1564-1577.
- [7] Sasaki, T., Kadoya, T. and Enomoto, K., Study on Load Frequency Control Using Redox Flow Batteries. *IEEE Transactions on Power System*. 2004; 19(1); 660-667.
- [8] Chidambaram AI and Paramasivam B. Optimized Load-Frequency Simulation in Restructured Power System with Redox Flow Batteries and Interline Power Flow Controller. *Electrical Power and Energy Systems*. 2013; 50; 9-24.
- [9] Chatterjee A, Goshal PS and Mukherjee V. Transient Performance Improvement of Grid Connected Hydro System using Distributed Generation and Capacitive Energy Storage Unit. *Elsevier Electrical Power and Energy Systems*. 2012; 43; 210-221.
- [10] Ali HM, Wu B and Dougal AR. *An Overview of SMES Applications in Power and Energy Systems*. *IEEE Transactions on Sustainable Energy*. 2010; 1(1); 38-47.
- [11] Arsoy BA and Wang Z. Transient Modelling and Simulation of a SMES Coil and the Power Electronics Interface. *IEEE Transactions on Applied Superconductivity*. 1999; 9(4); 4715-4724.
- [12] Demiroren A and Yesil E. Automatic Generation Control with Fuzzy Logic Controller in Power System Including SMES Unit Controllers. *Elsevier Electrical Power and Energy Systems*. 2004; 26; 291-305.
- [13] Ansari T Md M and Velusami S. Dual Mode Linguistic Hedge Fuzzy Logic Controller for an Isolated Wind-Diesel Hybrid Power System with Superconducting Magnetic Energy Storage Unit. *Elsevier Energy Conversion and Management*. 2010; 51; 169-181.
- [14] Pujiantara M and Abdillah M. (In English) Adaptive PI Controller Based on Bat Algorithm (BA) and Extreme Learning Machine (ELM) for Controlling Speed in Permanent Magnet Synchronous Motor. *Java Journal Electrical and Electronic Engineering*. 2011; 9(2); 113-122.
- [15] Niknam T, Abarghoee AR and Roosta A. Reserve Constrained Dynamic Economic Dispatch; A New Fast Self-Adaptive Modified Firefly Algorithm. *IEEE System Journal*. 2012; 6(4); 635-646.
- [16] Ali ES. Firefly Algorithm Based Speed Control of DC Series Motor. *WSEAS Transactions on System and Control*. 2015; 10.

- [17] Apostolopoulos T and Vlachos A. Application of the Firefly Algorithm for solving the Economic Emissions Load Dispatch Problem. *International Journal of Combinatorics*. 2011.
- [18] Roeva O and Slavov T. *Firefly Algorithm of PID Controller for Glucose Concentration Control during E. coli Fed-batch Cultivation Process*. Proceedings of the Federated Conference on Computer Science and Information System. 2012; 455-462.
- [19] Parimi MA, Elamvazuthi I, Saad N. *Damping of Inter Area Oscillations Using Interline Power Flow Controller Based Damping Controllers*. Proceedings 2nd IEEE International Conference on Power and Energy (PECon 08). Johor Baharu, Malaysia. December 1-3, 2008.
- [20] Kashki M, Abido AM, Magid-Abdel LY. Power System Dynamic Stability Enhancement Using Optimum Design of PSS and Static Phase Shifter Based Stabilizer. *Arabian Journal for Science and Engineering*. 2010; 38; 637-650.
- [21] Usman J, Mustafa WM, Aliyu G. Design of AVR and PSS for Power System Stability based on Iteration Particle swarm Optimization. *International Journal of Engineering and Innovative Technology (IJEIT)*. 2012; 2; 307-314;
- [22] Hakim AE, Soeprijanto A, Purnomo HM. Fuzzy PID based PSS Design Using Genetic Algorithm. *International Journal of Electrical Power and Energy System Engineering*. 2010; 3; 37-40.
- [23] De Mello FP and Corcodia C. Concepts of synchronous machine stability as affected by excitation control. *IEEE Transaction on Power Apparatus and Systems*. 1959; 8; 316-328.
- [24] Soeprijanto A. (In English) *Design Controller for Dynamic Stability Electric Power System*. Surabaya: Itsprees. 2012.
- [25] Robandi I. (In English) *Design Modern Power System: Optimization, Fuzzy Logic and Genetic Algorithm*. Yogyakarta: ANDI. 2005.
- [26] Yang XS. *Engineering Optimization: An Introduction with Metaheuristic Application*. New Jersey: WILEY. 2010.
- [27] Yang XS. *Nature-Inspired Metaheuristic Algorithms. Second Edition*. United Kingdom: Luniver. 2010
- [28] Haddin M, Soebagio, Soeprijanto A and Purnomo HM. Modeling and Control of Excitation and Governor Based on Particle Swarm Optimization for Micro Hydro Power Plant. *TELKOMNIKA Indonesian Journal of Electrical Engineering*. 2013; 11(2); 297-304.
- [29] El-Zonkoly MA, Khalil AA and Ahmed MN. Optimal Tuning of Lead-Lag and Fuzzy Logic Power System Stabilizer using Particle Swarm Optimization. *Expert System with Application*. 2009; 36; 2097-2106
- [30] Rogers G. *Power System Oscillation*. New York: Springer. 2000.
- [31] Milles RH and Malinowski JH. *Power System Operation*. New York: McGraw-Hill. 1994.